

# ECOMAX

insulated tile backer board



## INSTALLATION INSTRUCTIONS

**Ecomax** is a lightweight insulated tile backer board developed specifically for the thermal insulation of tiled floors. It is constructed from an extruded polystyrene core covered on both sides by a glass fibre mesh embedded in a cement skin. **Ecomax** has exceptional compressive strength.

### How to fix Ecomax to concrete floors

Ensure the floor is level and dust free. New concrete screed should be fully cured prior to laying the **Ecomax** board.

A bed of flexible tile adhesive should be applied to the floor using a notched trowel. Lay the boards in a staggered brick work pattern butting the edges together (see Fig. 1). Boards should be thoroughly bedded, ensuring that no air pockets remain.

A waterproof joint can be made using silicon sealant before butting the board edges together. When the adhesive is dry, board joints can be taped with a fibreglass reinforcing scrim tape (see Fig. 2).

### How to fix Ecomax to wooden floors

Boards can be fixed using a flexible tile adhesive as above.

A bed of flexible tile adhesive should be applied to the floor using a notched trowel. Lay the boards in a staggered brick work pattern butting the edges together (see Fig. 1). Boards should be thoroughly bedded, ensuring that no air pockets remain.

Alternatively 10mm boards can be mechanically fixed to flat and level timber floors using mechanical fixings (stainless steel screws with penny washers) at 30cm centres - 15 screws are recommended for each board. These should be screwed down until the washer grips the boards cementitious surface (see Fig. 3). Joints can be taped with a fibreglass reinforcing scrim tape (see Fig. 2).

6mm boards should NOT be mechanically fixed.

**Boards are now ready for fitting Flexel electric underfloor heating cable products.**

### Useful Information

Dimensions	600mm x 1250mm (0.75m <sup>2</sup> each)
Thickness	6mm or 10mm
Coverage per pack	4.5m <sup>2</sup> (6 Sheets)
Material	Extruded Polystyrene core with Polymer cement outer skin
Density	32Kg/m <sup>3</sup>
Thermal Conductivity	0.029W/m <sup>0</sup> k
Compressive Strength	300kN/m <sup>2</sup>
Water Absorption (immersion)	<1.5% by vol
Water Absorption (capillary)	Nil
Co-efficient of Linear Expansion	0.07mm/mK
Flamibility	B1

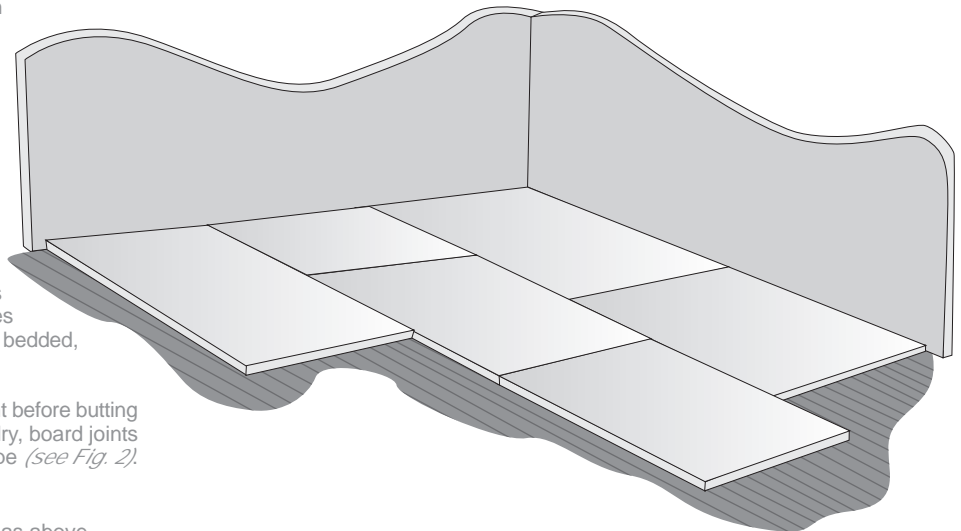

Fig.1

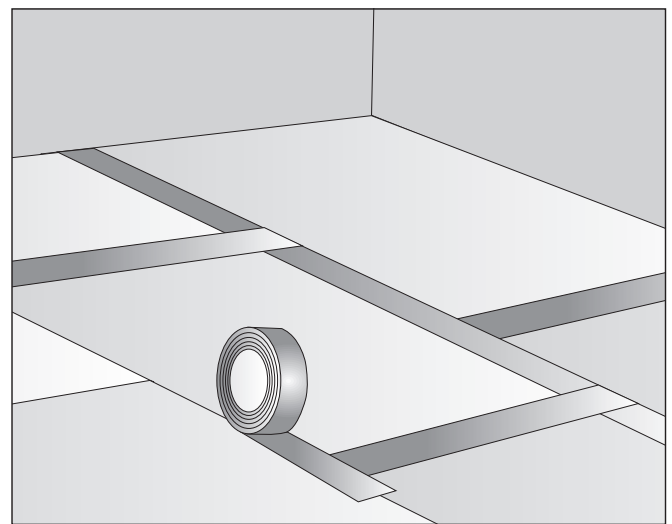

Fig.2

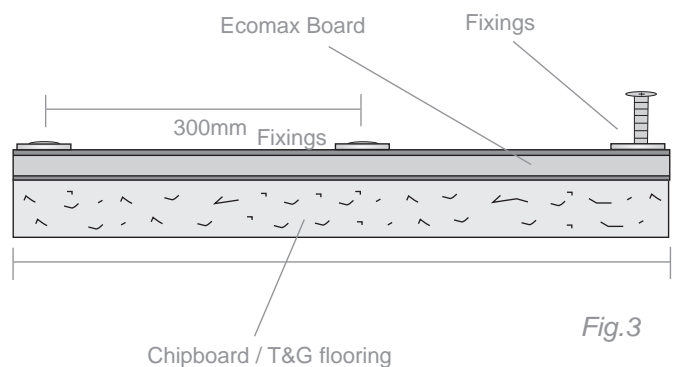

Fig.3