

# **FIBROTHAL® Handbook** **Heating and** **Insulation Systems**



**KANTHAL**

Catalogue 8-A-1-3 04-08-3000

© Kanthal AB

May be reproduced only with proper acknowledgement of the source.

**Disclaimer:** The information contained in this document is for illustrative purposes only. The data and examples are only general recommendations, and not a warranty or a guarantee that such data will function in individual/specific cases. The purchaser of a Kanthal product has the responsibility to control the applicability of Kanthal's products in a specific application before using them.

© KANTHAL, NIKROTHAL and FIBROTHAL are registered trademarks of Kanthal Group companies in Sweden and other countries.

# Contents

<b>Introduction</b> .....	<b>4</b>
Brief Description of FIBROTHAL Heating and Insulation Systems .....	5
<b>Technical Data – General</b> .....	<b>6</b>
KF Modules .....	6
Tolerances .....	7
Atmospheres .....	8
Power Limitation .....	9
<b>Technical Data – Standard Range</b> .....	<b>11</b>
Heating Modules .....	11
Panels .....	13
Half-Cylinders .....	18
Tubes .....	21
Insulating Parts .....	23
<b>Modules to Special Design</b> .....	<b>24</b>
Modules with Embedded Heating .....	24
ROB in Panel and Shell Design .....	25
Meanderthal II and III .....	26
Special Tube Modules .....	27
Muffles .....	28
Insulating Parts .....	29
<b>Accessories</b> .....	<b>30</b>
Flexible Bead-Insulated Connecting Leads .....	30
Ceramics Tubes with Flange .....	33
Ceramic Insulators and Plugs .....	33
<b>Assembly</b> .....	<b>35</b>
Attaching FIBROTHAL Modules .....	35
Sealing the Joints .....	37
Welding on the Heating Element .....	37
<b>Overview of the Heating Systems</b> .....	<b>39</b>
<b>Voltage and Power Conversion for Standard Modules</b> .....	<b>41</b>
Calculation Example .....	41



## Introduction

Lightweight construction has become the norm in many industrial furnaces, with the use of ceramic fibers (KF) up to furnace temperatures of 1550°C (2820°F).

The low thermal mass and thermal conductivity of the ceramic fiber furnace linings mean that you can build industrial furnaces which, depending on the type and mode of operation, contribute significantly to energy saving, higher output and better availability.

In the electrically heated furnace, however, it is very expensive and time consuming to combine ceramic fibers, such as blankets or folding blocks, with electric heating elements. This has led to the product concept which we introduced to the market in 1978 under the name FIBROTHAL.

Today the name FIBROTHAL covers a family of products consisting of vacuum-formed ceramic fiber components, with or without electric heating elements.

## FIBROTHAL Heating and Insulation Systems

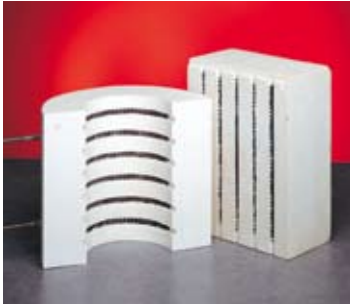

Fig. 1 Heating modules with embedded heating elements made of KANTHAL® alloys for a maximum element temperature of 1150°C (2100°F)



Fig. 2 RAC tubes with embedded but virtually free-radiating heating element, for a maximum element temperature of 1300°C (2370°F)



Fig. 3 Meanderthal II module with free-radiating heating elements for a maximum element temperature of 1300°C (2370°F), mainly for roof heating and tilting furnaces

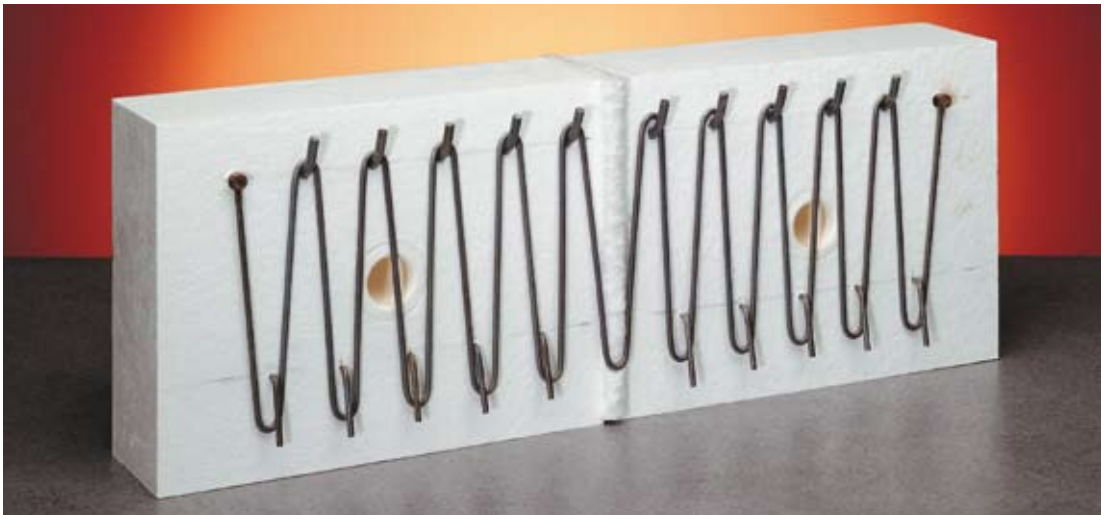

Fig. 4 ROB with free-radiating heating elements for a maximum element temperature of 1300°C (2370°F), mainly for wall and floor heating



Fig. 5 Muffles with embedded heating elements made of KANTHAL alloys for a maximum element temperature of 1150°C (2100°F)



Fig. 6 Insulation parts of vacuum-formed fiber in the most varied shapes for application temperatures up to 1550°C (2820°F)



Fig. 7 FibroSiC are unsupported roof insulating parts, which are strengthened by SiC tubes

# Technical Data – General

## KF-Modules

**Chemical Properties:** KF-modules possess high resistance to chemicals, including most acids, with the exception of hydrofluoric acid, phosphoric acid and strong bases. Wetting with water and oil has no influence on the properties of the ceramic fibers them-

selves. After drying or evaporation the thermal and physical properties are restored. Care must be taken when they are fitted with heating elements because of possible corrosion.

	F-3/LS	F-17/LS	F-19	F-14
<b>Classification temp. [°C] (°F)*</b>	1260 (2300)	1400 (2550)	1500 (2730)	1600 (2910)
<b>Max. continuous duty temperature [°C] (°F)</b>	1150 (2100)	1300 (2370)	1400 (2550)	1550 (2820)
<b>Density approx. [kg/m<sup>3</sup>] (lb/ft<sup>3</sup>)</b>	200 (12.48)	200 (12.48)	200 (12.48)	250 (15.61)
<b>Linear shrinkage [%]</b> (24 hours at maximum continuous duty temp.)	3/<1	4.5/<2	4.5	3.5
<b>Guide analysis [%]:</b>				
<b>Al<sub>2</sub>O<sub>3</sub></b>	46	50	67	77
<b>SiO<sub>2</sub></b>	54	50	33	23
<b>Thermal conductivity [W/mk]**</b>				
<b>at 200°C (390°F)</b>	0.07	0.07	0.07	–
<b>at 400°C (750°F)</b>	0.10	0.10	0.10	0.09
<b>at 600°C (1110°F)</b>	0.14	0.14	0.14	0.13
<b>at 800°C (1470°F)</b>	0.21	0.21	0.20	0.19
<b>at 1000°C (1830°F)</b>	0.28	0.29	0.28	0.24
<b>at 1200°C (2190°F)</b>	–	0.41	0.39	0.35
<b>at 1300°C (2370°F)</b>	–	0.49	0.46	0.39
<b>at 1400°C (2550°F)</b>	–	–	0.54	0.46
<b>at 1500°C (2730°F)</b>	–	–	–	0.54
<b>at 1600°C (2910°F)</b>	–	–	–	–

\*Classification temperature of the fibers used

\*\*Measuring method: calorimeter

Fiber free versions see MODUTHAL brochure  
Bio soluble fiber and special fiber grades on request

Table 1 Technical data of ceramic fiber modules

## Tolerances

### Module Dimensions

The following tolerances apply to the vacuum-formed insulation with or without heating element.

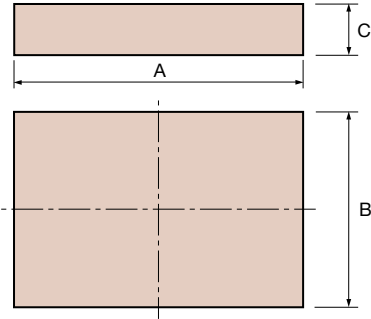

A and B [mm] (in)		C, with machining on one surface [mm] (in)		two surfaces [mm] (in)	
≤ 700 (≤ 27.6)	± 3 (± 0.12)	± 5 (± 0.20)	± 5 (± 0.20)	± 3 (± 0.12)	± 3 (± 0.12)
> 700 (> 27.6)	± 5 (± 0.20)	+ 5/- 10 (+ 0.20/- 0.39)	+ 5/- 10 (+ 0.20/- 0.39)	± 3 (± 0.12)	± 3 (± 0.12)

Fig. 8 FIBROTHAL panels

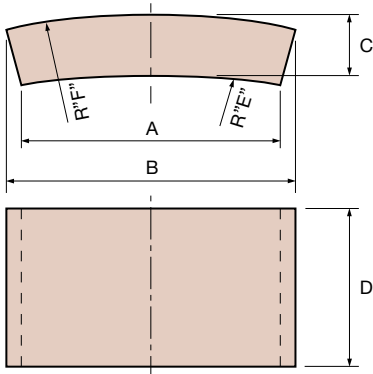

A, B and D [mm] (in)		C [mm] (in)	R "E" [mm] (in)	R "F" [mm] (in)
≤ 700 (≤ 27.6)	± 3 (± 0.12)	± 5 (± 0.20)	± 5 (± 0.20)	± 5 (± 0.20)
> 700 (> 27.6)	± 5 (± 0.20)		± 10 (± 0.39)	± 10 (± 0.39)

Fig. 10 FIBROTHAL shells

Electrical resistance:  $R_k \pm 5\%$

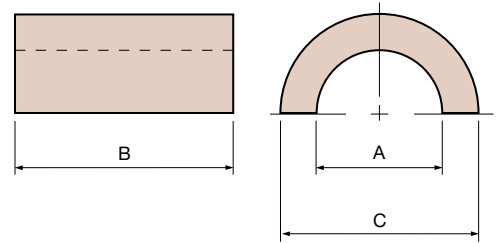

A [mm] (in)		B [mm] (in)	C [mm] (in)	
≤ 200 (≤ 7.9)	+ 4 (+ 0.16)	± 3 (± 0.12)	≤ 350 (≤ 13.8)	± 5 (± 0.20)
200–350 (7.9–3.8)	+ 6 (+ 0.24)		> 350 (> 13.8)	± 10 (± 0.39)
> 350 (> 13.8)	+ 10 (+ 0.39)			

Fig. 9 FIBROTHAL half-cylinders

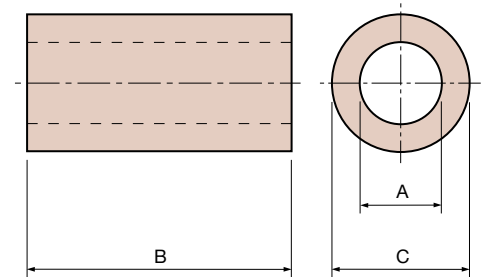

A [mm] (in)	B [mm] (in)	C [mm] (in)
+ 8/- 2 (+ 0.31/- 0.08)	+ 10/- 5 (+ 0.39/- 0.20)	± 10 (± 0.39)

Fig. 11 FIBROTHAL tubes

## Atmospheres

Furnace atmosphere	Max. element temperature		Remarks
	KANTHAL heating elements	FIBROTHAL heating elements	
H <sub>2</sub>	1400°C (2550°F)	1000°C (1830°F)	H <sub>2</sub> increases heat throughput of FIBROTHAL 3–4 times.
N <sub>2</sub>	1200°C preoxidized (2190°F)	1150°C preoxidized (2100°F)	FIBROTHAL heating modules without heating elements up to maximum duty temperature.
N	don't use	don't use	
Endogas	1050°C preoxidized (1920°F)	1050°C preoxidized (1920°F)	Pay attention to carbon deposition! Better with gas-tight muffle.
Exogas	1150°C preoxidized (2100°F)	1050°C preoxidized (1920°F)	Pay attention to carbon deposition! Better with gas-tight muffle.
Sulphur	approx. 1000°C (1830°F)	—	Does not withstand sulphur pentoxide.
Chlorine, fluorine, alkali	attacks all types of resistance alloys	attacks all types of resistance alloys	FIBROTHAL can be used without elements below 900°C (1650°F).
Vacuum < 10 <sup>-3</sup> mbar	1150°C preoxidized (2100°F)	800–850°C (1470–1560°F)	Vacuum higher than 10 <sup>-3</sup> mbar will take too long to evacuate the fiber block. Better with vacuum-tight muffle.
Pressurized	1400°C (2550°F)	1250°C (2280°F)	FIBROTHAL can be used in gas or air-tight furnaces only.
Scale	see remarks	see remarks	Spray scale from heat-resistant parts is usually satisfactorily tolerated, iron oxide scale attacks KANTHAL – fit cover.
Vapours	see remarks	see remarks	Vapours must not form condensates from salts or oxides, otherwise electrical bridges will be formed.
Gas velocity	see remarks	see remarks	FIBROTHAL withstands high gas velocities up to 50 m/s (112 mph). Pay attention to butt joints with ceramic fiber blankets.

Table 2 Maximum permissible element temperatures in various furnace atmospheres



## Power Limitation

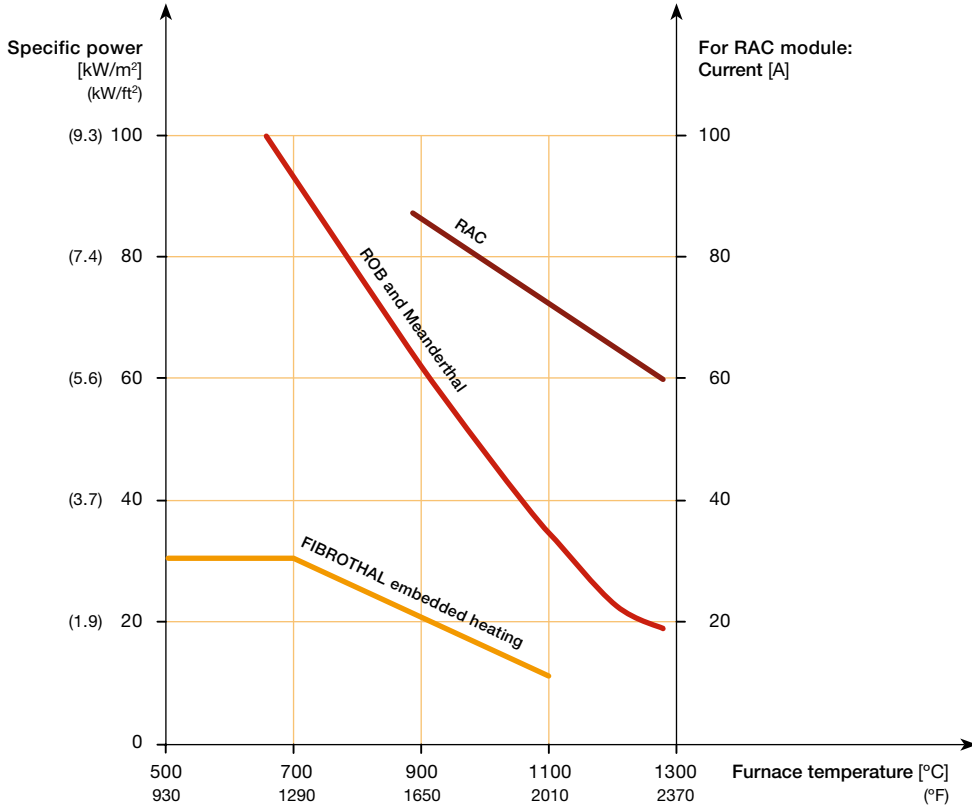

Fig. 12 Shows for the various heating module designs the maximum recommended load in relation to the furnace temperature

### Rule of Thumb

To install a voltage of 230 V with a free radiating wire (ROB, Meanderthal) an area of 1 m<sup>2</sup> (10.8 ft<sup>2</sup>) is needed.

To install a voltage of 230 V with an embedded element (FIBROTHAL) an area of 0.25 m<sup>2</sup> (2.7 ft<sup>2</sup>) is needed.



# Technical Data – Standard Range

## Heating Modules

FIBROTHAL standard heating modules are manufactured with embedded heating elements, two principles being followed.

### Principle I

With this method the KANTHAL A-1 heating wires (diameter < 3.5 mm (0.14 in)) are embedded in the ceramic fiber module made of F3 fiber. The maximum element temperature is 1150°C (2100°F).

**This design is protected by patent.**

### For optimum heat radiation:

- The heating wire is made with an oval cross-section
- Part of the face of the heating wire is bare
- The inside of the heating wires is largely free of ceramic fibers

Panels and half-cylinders are manufactured according to this principle.

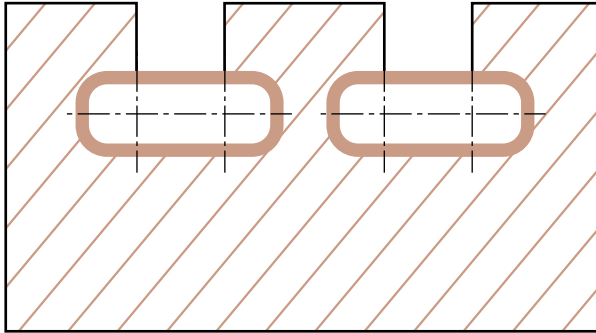

Fig. 13 Embedding principle

## Principle II

With this method – used exclusively for heating tubes – a heating wire of KANTHAL A-1 (diameter 5 mm (0.20 in)) is formed to fit into a ceramic fiber module of F17 fiber with ceramic spacers. In this case the heating element lies on the surface of the insulation and is virtually free-radiating. The maximum element temperature is 1300°C (2370°F).

A complete range of moulds is available for manufacturing the standard modules. There are therefore no mould costs in this case.

In the new edition of this brochure the previous voltages have been converted to the Eurovoltage (400/230 V). The modules can however also be operated with the voltages previously used (380/220 V or 415/240 V).

If low power is required, the modules can also be operated at lower voltages. Higher power is also possible if allowance is made for the maximum wall loading (see Fig. 12).

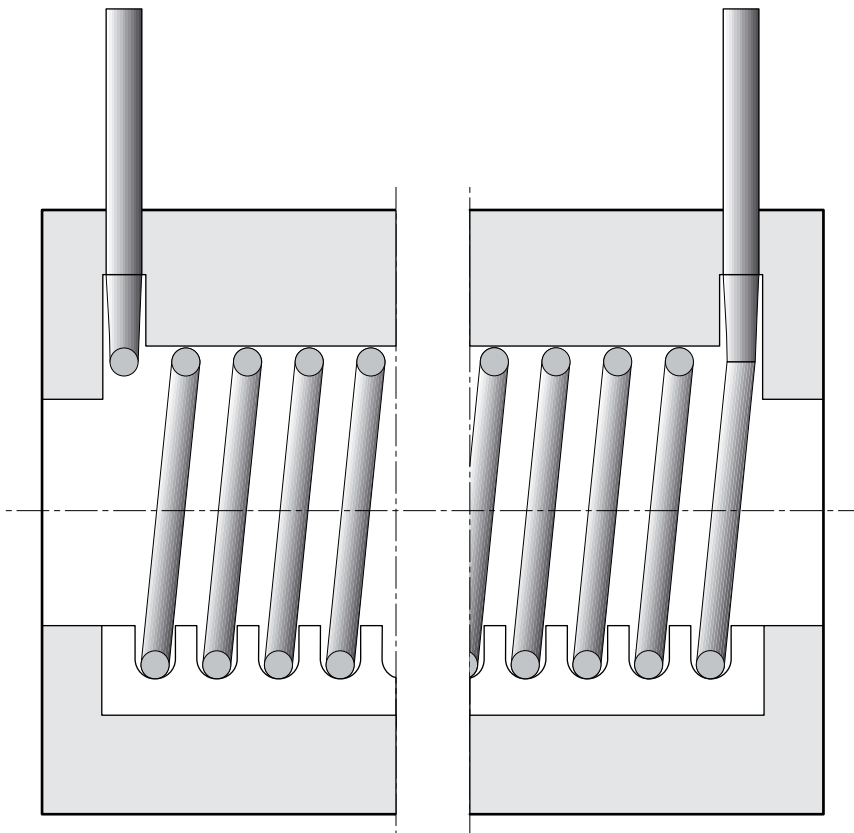

Fig. 14 RAC forming principle

## Panels

The heating surface is the surface which accommodates the heating element. The standard module dimensions are based on the heated surface dimensions plus the minimum required unheated edge area. Panels can be manufactured to a maximum width or length of 1050 mm (41.4 in).

Unheated edges can be manufactured to any dimension as long as the overall panel dimension does not exceed the maximum width or length already specified. Standard modules can also be supplied with additional 125 mm (4.92 in) unheated edges on either the width or length (type SL; SB).

If modules are to be attached to roofs or side walls, there is a design available with ceramic cup assembly mountings. For roofs in particular we recommend additional element anchorage using ceramic cement pins.

The standard design of connections is in the form of threaded rod M8 × 75 mm (2.95 in) long at the back of the module. Other connection designs are available on request, e. g. flexible leads (see accessories).

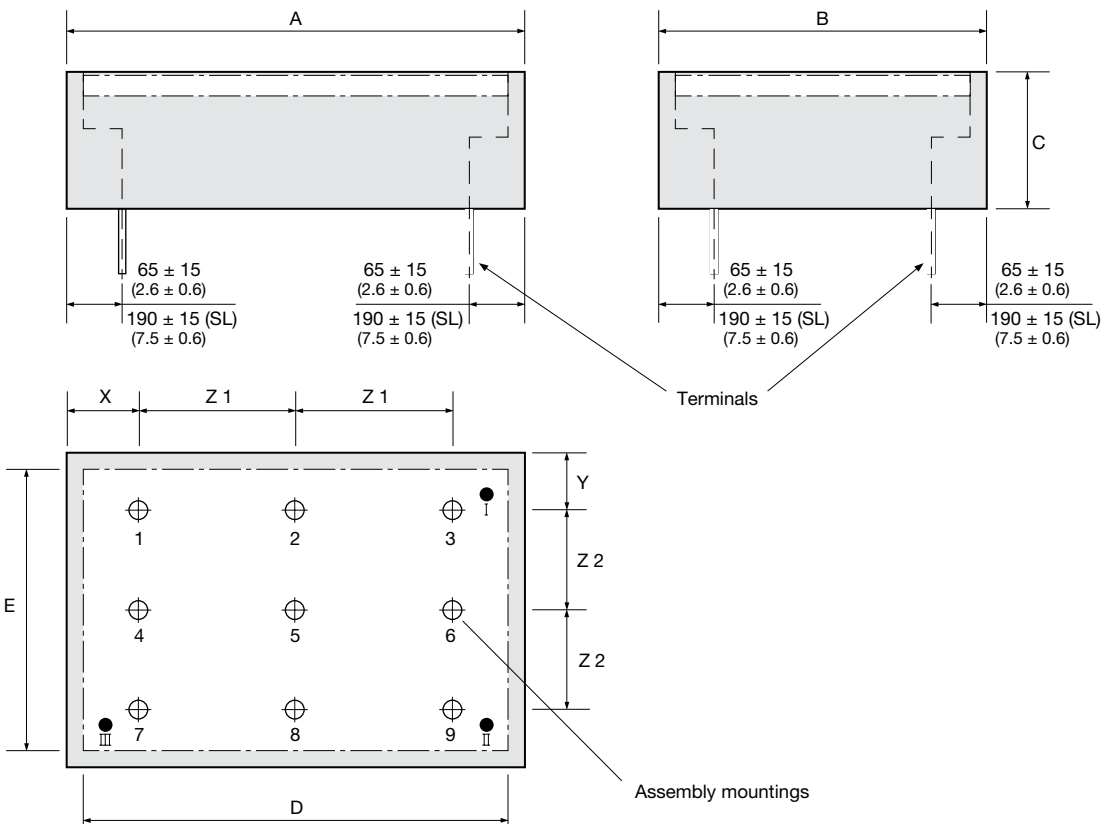

Fig. 15 FIBROTHAL standard panels

## FIBROTHAL Heating Panels

Type designation	Part No.	Standard dim. A × B × C [mm]	Heated area D × E [mm]	Power [W]	Voltage [V]	Resistance R20 [Ohm]	Term. arr. Position	Assembly Nos. Pcs./Pos.	Grid dim. X/Z1 Y/Z2 [mm]	Approx. weight [kg]
PAS 300/225/57.5	DF830004	300×225×125	270×195	1050	57.5	3.03	I-III	-	-	2.1
PAS 300/225/57.5 S/D	DF830007	300×225×125	270×195	1050	57.5	3.03	I-III	2/1-9	75/150 92/42	2.1
PAS 300/225/57.5 SL	DF830011	550×225×125	270×195	1050	57.5	3.03	I-III	-	-	3.5
PAS 300/225/57.5 SB	DF830012	300×475×125	270×195	1050	57.5	3.03	I-III	-	-	3.9
PAS 375/225/57.5	DF830016	375×225×125	335×195	1350	57.5	2.35	I-III	-	-	2.7
PAS 375/225/57.5 S/D	DF830019	375×225×125	335×195	1350	57.5	2.35	I-III	2/1-9	75/112 92/21	2.7
PAS 375/225/57.5 SL	DF830021	625×225×125	335×195	1350	57.5	2.35	I-III	-	-	4.1
PAS 375/225/57.5 SB	DF830022	375×475×125	335×195	1350	57.5	2.35	I-III	-	-	5
PAS 450/300/100	DF830026	450×300×125	410×250	2100	100	4.58	I-II	-	-	4.2
PAS 450/300/100 S/D	DF830029	450×300×125	410×250	2100	100	4.58	I-II	2/4-6	100/125 150/0	4.2
PAS 450/300/100 SL	DF830031	700×300×125	410×250	2100	100	4.58	I-II	-	-	6.1
PAS 450/300/100 SB	DF830032	450×550×125	410×250	2100	100	4.58	I-II	-	-	7
PAS 450/300/115	DF830036	450×300×125	410×250	2100	115	6.06	I-II	-	-	4.2
PAS 450/300/115 S/D	DF830039	450×300×125	410×250	2100	115	6.06	I-II	2/4-6	100/125 150/0	4.2
PAS 450/300/115 SL	DF830041	700×300×125	410×250	2100	115	6.06	I-II	-	-	6.1
PAS 450/300/115 SB	DF830042	450×550×125	410×250	2100	115	6.06	I-II	-	-	7
PAS 450/300/133	DF830046	450×300×125	410×250	2100	133	8.1	I-III	-	-	4.5
PAS 450/300/133 S/D	DF830049	450×300×125	410×250	2100	133	8.1	I-III	2/1-9	100/125 131/19	4.5
PAS 450/300/133 SL	DF830051	700×300×125	410×250	2100	133	8.1	I-III	-	-	5.9
PAS 450/300/133 SB	DF830052	450×550×125	410×250	2100	133	8.1	I-III	-	-	6.9
PAS 450/375/115	DF830056	450×375×125	410×325	2700	115	4.9	I-II	-	-	4.5
PAS 450/375/115 S/D	DF830059	450×375×125	410×325	2700	115	4.9	I-II	2/4-6	100/125 187/0	4.5
PAS 450/375/115 SL	DF830061	700×375×125	410×325	2700	115	4.9	I-II	-	-	7.7
PAS 450/375/115 SB	DF830062	450×625×125	410×325	2700	115	4.9	I-II	-	-	8.2
PAS 450/375/133	DF830066	450×375×125	410×325	2700	133	6.3	I-II	-	-	5.3
PAS 450/375/133 S/D	DF830069	450×375×125	410×325	2700	133	6.3	I-II	2/4-6	100/125 187/0	5.3
PAS 450/375/133 SL	DF830071	700×375×125	410×325	2700	133	6.3	I-II	-	-	7.7
PAS 450/375/133 SB	DF830072	450×625×125	410×325	2700	133	6.3	I-II	-	-	8

Table 3a Standard FIBROTHAL heating panel designs (metric figures)

Type designation	Part No.	Standard dim. A × B × C [mm]	Heated area D × E [mm]	Power [W]	Voltage [V]	Resistance R20 [Ohm]	Term. arr. Position	Assembly Nos. Pcs./Pos.	Grid dim. X/Z1 Y/Z2 [mm]	Approx. weight [kg]
PAS 600/450/200	DF830076	600×450×125	550×405	4200	200	9.16	I–II	–	–	8.7
PAS 600/450/200 S	DF830079	600×450×125	550×405	4200	200	9.16	I–II	2/4-6	150/150 225/0	8.7
PAS 600/450/200 D	DF830082	600×450×125	550×405	4200	200	9.16	I–II	4/1-3-7-9	150/150 100/125	8.7
PAS 600/450/200 SL	DF830083	850×450×125	550×405	4200	200	9.16	I–II	–	–	11.5
PAS 600/450/200 SB	DF830084	600×700×125	550×405	4200	200	9.16	I–II	–	–	12.5
PAS 600/450/230	DF830088	600×450×125	550×405	4200	230	12.11	I–II	–	–	8.6
PAS 600/450/230 S	DF830091	600×450×125	550×405	4200	230	12.11	I–II	2/4-6	150/150 225/0	8.6
PAS 600/450/230 D	DF830094	600×450×125	550×405	4200	230	12.11	I–II	4/1-3-7-9	150/150 100/125	8.6
PAS 600/450/230 SL	DF830095	850×450×125	550×405	4200	230	12.11	I–II	–	–	11.4
PAS 600/450/230 SB	DF830096	600×700×125	550×405	4200	230	12.11	I–II	–	–	12.3
PAS 750/450/200	DF830100	750×450×125	700×405	5400	200	7.12	I–III	–	–	11.1
PAS 750/450/200 S	DF830103	750×450×125	700×405	5400	200	7.12	I–III	2/4-6	143/232 225/0	11.1
PAS 750/450/200 D	DF830106	750×450×125	700×405	5400	200	7.12	I–III	6/1-2-3-7-8-9	–	11.1
PAS 750/450/200 SL	DF830107	1000×450×125	700×405	5400	200	7.12	I–III	–	–	14
PAS 750/450/200 SB	DF830108	750×700×125	700×405	5400	200	7.12	I–III	–	–	15.8
PAS 750/450/230	DF830112	750×450×125	700×405	5400	230	9.42	I–III	–	–	15.4
PAS 750/450/230 S	DF830115	750×450×125	700×405	5400	230	9.42	I–III	2/4-6	143/232 225/0	15.4
PAS 750/450/230 D	DF830118	750×450×125	700×405	5400	230	9.42	II–III	6/1-2-3-7-8-9	100/126 100/125	15.4
PAS 750/450/230 SL	DF830119	1000×450×125	700×405	5400	230	9.42	I–III	–	–	13.5
PAS 750/450/230 SB	DF830120	750×700×125	700×405	5400	230	9.42	I–III	–	–	15.4
PAS 900/600/400	DF830124	900×600×125	825×540	8400	400	18.32	II–III	–	–	17.4
PAS 900/600/400 S	DF830127	900×600×125	825×540	8400	400	18.32	II–III	2/4-6	198/252 300/0	17.5
PAS 900/600/400 D	DF830130	900×600×125	825×540	8400	400	18.32	II–III	6/1-2-3-7-8-9	156/147 150/150	17.4
PAS 900/600/400 SL	DF830472	1150×600×125	825×540	8400	400	18.32	II–III	1-3-7-9	75/500 150/300	23
PAS 900/600/400 SB	DF830131	900×850×125	825×540	8400	400	18.32	II–III	–	–	23
PAS 900/750/400	DF830135	900×750×125	825×680	10800	400	14.25	II–III	–	–	22.3
PAS 900/750/400 S	DF830138	900×750×125	825×680	10800	400	14.25	II–III	2/4-6	198/252 375/0	22.3
PAS 900/750/400 D	DF830141	900×750×125	825×680	10800	400	14.25	II–III	9/1...9	156/147 100/138	22.3
PAS 900/750/400 SB	DF830142	900×1000×125	825×680	10800	400	14.25	II–III	–	–	27.9

Table 3a Standard FIBROTHAL heating panel designs (metric figures)

## FIBROTHAL Heating Panels

Type designation	Part No.	Standard dim. A × B × C [in]	Heated area D × E [in]	Power [W]	Voltage [V]	Resistance R20 [Ω]	Term. arr. Position	Assembly Nos. Pcs./Pos.	Grid dim. X/Z1 Y/Z2 [in]	Approx. weight [lb]
PAS 300/225/57.5	DF830004	11.8×8.9×4.9	10.6×7.7	1050	57.5	3.03	I-III	-	-	4.6
PAS 300/225/57.5 S/D	DF830007	11.8×8.9×4.9	10.6×7.7	1050	57.5	3.03	I-III	2/1-9	3.0/5.9 3.6/1.7	4.6
PAS 300/225/57.5 SL	DF830011	21.7×8.9×4.9	10.6×7.7	1050	57.5	3.03	I-III	-	-	7.7
PAS 300/225/57.5 SB	DF830012	11.8×18.7×4.9	10.6×7.7	1050	57.5	3.03	I-III	-	-	8.6
PAS 375/225/57.5	DF830016	14.8×8.9×4.9	13.2×7.7	1350	57.5	2.35	I-III	-	-	6.0
PAS 375/225/57.5 S/D	DF830019	14.8×8.9×4.9	13.2×7.7	1350	57.5	2.35	I-III	2/1-9	3.0/4.4 3.6/0.8	6.0
PAS 375/225/57.5 SL	DF830021	24.6×8.9×4.9	13.2×7.7	1350	57.5	2.35	I-III	-	-	9.0
PAS 375/225/57.5 SB	DF830022	14.8×18.7×4.9	13.2×7.7	1350	57.5	2.35	I-III	-	-	11.0
PAS 450/300/100	DF830026	17.7×11.8×4.9	16.1×9.8	2100	100	4.58	I-II	-	-	9.3
PAS 450/300/100 S/D	DF830029	17.7×11.8×4.9	16.1×9.8	2100	100	4.58	I-II	2/4-6	3.9/4.9 5.9/0	9.3
PAS 450/300/100 SL	DF830031	27.6×11.8×4.9	16.1×9.8	2100	100	4.58	I-II	-	-	13.4
PAS 450/300/100 SB	DF830032	17.7×21.7×4.9	16.1×9.8	2100	100	4.58	I-II	-	-	15.4
PAS 450/300/115	DF830036	17.7×11.8×4.9	16.1×9.8	2100	115	6.06	I-II	-	-	9.3
PAS 450/300/115 S/D	DF830039	17.7×11.8×4.9	16.1×9.8	2100	115	6.06	I-II	2/4-6	3.9/4.9 5.9/0	9.3
PAS 450/300/115 SL	DF830041	27.6×11.8×4.9	16.1×9.8	2100	115	6.06	I-II	-	-	13.4
PAS 450/300/115 SB	DF830042	17.7×21.7×4.9	16.1×9.8	2100	115	6.06	I-II	-	-	15.4
PAS 450/300/133	DF830046	17.7×11.8×4.9	16.1×9.8	2100	133	8.1	I-III	-	-	9.9
PAS 450/300/133 S/D	DF830049	17.7×11.8×4.9	16.1×9.8	2100	133	8.1	I-III	2/1-9	3.9/4.9 5.2/0.7	9.9
PAS 450/300/133 SL	DF830051	27.6×11.8×4.9	16.1×9.8	2100	133	8.1	I-III	-	-	13.0
PAS 450/300/133 SB	DF830052	17.7×21.7×4.9	16.1×9.8	2100	133	8.1	I-III	-	-	15.2
PAS 450/375/115	DF830056	17.7×14.8×4.9	16.1×12.8	2700	115	4.9	I-II	-	-	9.9
PAS 450/375/115 S/D	DF830059	17.7×14.8×4.9	16.1×12.8	2700	115	4.9	I-II	2/4-6	13.9/4.9 7.4/0	9.9
PAS 450/375/115 SL	DF830061	27.6×14.8×4.9	16.1×12.8	2700	115	4.9	I-II	-	-	17.0
PAS 450/375/115 SB	DF830062	17.7×24.6×4.9	16.1×12.8	2700	115	4.9	I-II	-	-	18.0
PAS 450/375/133	DF830066	17.7×14.8×4.9	16.1×12.8	2700	133	6.3	I-II	-	-	11.7
PAS 450/375/133 S/D	DF830069	17.7×14.8×4.9	16.1×12.8	2700	133	6.3	I-II	2/4-6	3.9/4.9 7.4/0	11.7
PAS 450/375/133 SL	DF830071	27.6×14.8×4.9	16.1×12.8	2700	133	6.3	I-II	-	-	17.0
PAS 450/375/133 SB	DF830072	17.7×24.6×4.9	16.1×12.8	2700	133	6.3	I-II	-	-	17.6

Table 3b Standard FIBROTHAL heating panel designs (imperial figures)



Type designation	Part No.	Standard dim. A × B × C [in]	Heated area D × E [in]	Power [W]	Voltage [V]	Resistance R20 [Ohm]	Term. arr. Position	Assembly Nos. Pcs./Pos.	Grid dim. X/Z1 Y/Z2 [in]	Approx. weight [lb]
PAS 600/450/200	DF830076	23.6×17.7×4.9	21.7×15.9	4200	200	9.16	I-II	-	-	19.2
PAS 600/450/200 S	DF830079	23.6×17.7×4.9	21.7×15.9	4200	200	9.16	I-II	2/4-6	5.9/5.9 8.9/0	19.2
PAS 600/450/200 D	DF830082	23.6×17.7×4.9	21.7×15.9	4200	200	9.16	I-II	4/1-3-7-9	5.9/5.9 3.9/4.9	19.2
PAS 600/450/200 SL	DF830083	33.5×17.7×4.9	21.7×15.9	4200	200	9.16	I-II	-	-	25.4
PAS 600/450/200 SB	DF830084	23.6×27.6×4.9	21.7×15.9	4200	200	9.16	I-II	-	-	27.6
PAS 600/450/230	DF830088	23.6×17.7×4.9	21.7×15.9	4200	230	12.11	I-II	-	-	19.0
PAS 600/450/230 S	DF830091	23.6×17.7×4.9	21.7×15.9	4200	230	12.11	I-II	2/4-6	5.9/5.9 8.9/0	19.0
PAS 600/450/230 D	DF830094	23.6×17.7×4.9	21.7×15.9	4200	230	12.11	I-II	4/1-3-7-9	5.9/5.9 3.9/4.9	19.0
PAS 600/450/230 SL	DF830095	33.5×17.7×4.9	21.7×15.9	4200	230	12.11	I-II	-	-	25.1
PAS 600/450/230 SB	DF830096	23.6×27.6×4.9	21.7×15.9	4200	230	12.11	I-II	-	-	27.1
PAS 750/450/200	DF830100	29.5×17.7×4.9	27.6×15.9	5400	200	7.12	I-III	-	-	24.5
PAS 750/450/200 S	DF830103	29.5×17.7×4.9	27.6×15.9	5400	200	7.12	I-III	2/4-6	5.6/9.1 8.9/0	24.5
PAS 750/450/200 D	DF830106	29.5×17.7×4.9	27.6×15.9	5400	200	7.12	I-III	6/1-2-3-7-8-9	-	24.5
PAS 750/450/200 SL	DF830107	39.4×17.7×4.9	27.6×15.9	5400	200	7.12	I-III	-	-	30.9
PAS 750/450/200 SB	DF830108	29.5×27.6×4.9	27.6×15.9	5400	200	7.12	I-III	-	-	34.8
PAS 750/450/230	DF830112	29.5×17.7×4.9	27.6×15.9	5400	230	9.42	I-III	-	-	34.0
PAS 750/450/230 S	DF830115	29.5×17.7×4.9	27.6×15.9	5400	230	9.42	I-III	2/4-6	5.6/9.1 8.9/0	34.0
PAS 750/450/230 D	DF830118	29.5×17.7×4.9	27.6×15.9	5400	230	9.42	II-III	6/1-2-3-7-8-9	3.9/5.0 3.9/4.9	34.0
PAS 750/450/230 SL	DF830119	39.4×17.7×4.9	27.6×15.9	5400	230	9.42	I-III	-	-	29.8
PAS 750/450/230 SB	DF830120	29.5×27.6×4.9	27.6×15.9	5400	230	9.42	I-III	-	-	34.0
PAS 900/600/400	DF830124	35.4×23.6×4.9	32.5×21.3	8400	400	18.32	II-III	-	-	38.4
PAS 900/600/400 S	DF830127	35.4×23.6×4.9	32.5×21.3	8400	400	18.32	II-III	2/4-6	7.8/9.9 11.8/0	38.6
PAS 900/600/400 D	DF830130	35.4×23.6×4.9	32.5×21.3	8400	400	18.32	II-III	6/1-2-3-7-8-9	6.1/5.8 5.9/5.9	38.4
PAS 900/600/400 SL	DF830472	45.3×23.6×4.9	32.5×21.3	8400	400	18.32	II-III	1-3-7-9	3.0/19.7 5.9/11.8	50.7
PAS 900/600/400 SB	DF830131	35.4×33.5×4.9	32.5×21.3	8400	400	18.32	II-III	-	-	50.7
PAS 900/750/400	DF830135	35.4×29.5×4.9	32.5×26.8	10800	400	14.25	II-III	-	-	49.2
PAS 900/750/400 S	DF830138	35.4×29.5×4.9	32.5×26.8	10800	400	14.25	II-III	2/4-6	7.8/9.9 33.0/0	49.2
PAS 900/750/400 D	DF830141	35.4×29.5×4.9	32.5×26.8	10800	400	14.25	II-III	9/1...9	6.1/5.8 3.9/5.4	49.2
PAS 900/750/400 SB	DF830142	35.4×39.4×4.9	32.5×26.8	10800	400	14.25	II-III	-	-	61.5

Table 3b Standard FIBROTHAL heating panel designs (imperial figures)

## Half-Cylinders

For horizontal operation the upper half shell should be designed for the pin system (for explanation see Heating Panels).

The connections are designed as standard in the form of threaded bolts  $M8 \times 75 \text{ mm}$  (2.95 in) long on the back of the module. Other connection designs are available on request, e.g. flexible leads (see Accessories).

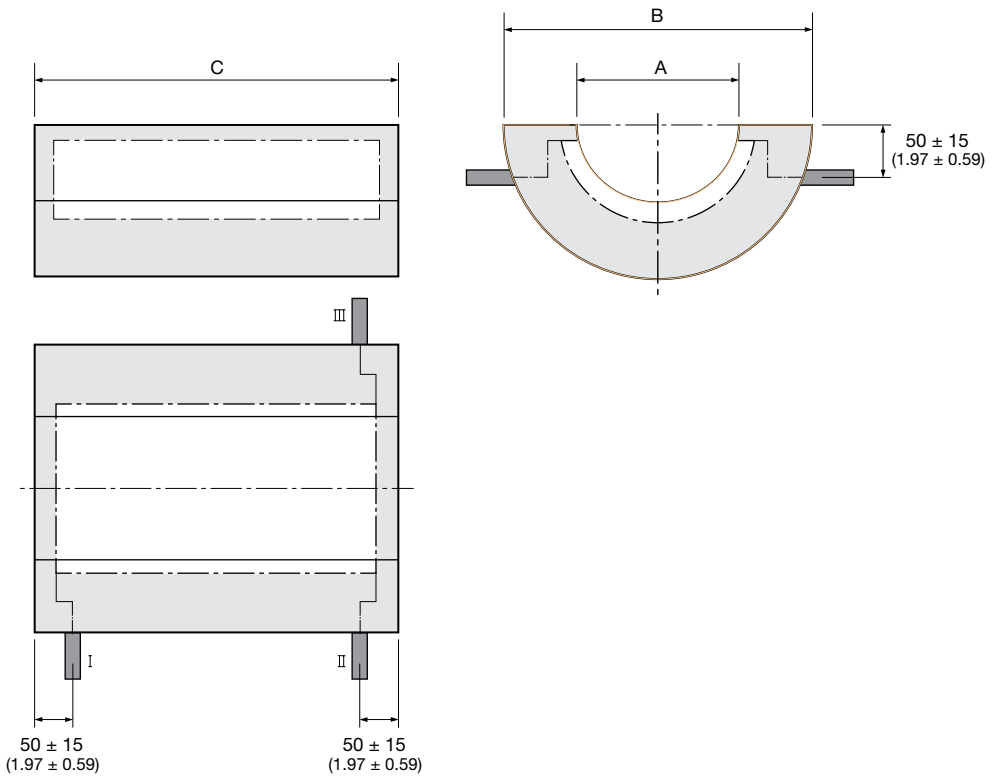

Fig. 16 FIBROTHAL standard half-cylinders

## FIBROTHAL Half-cylinders

Type designation	Part No.	Ø i.d. A [mm]	Ø o.d. B [mm]	Length C [mm]	Power [W]	Voltage [V]	Resistance R20 [Ohm]	Terminal arr. Position	Approx. weight [kg]
HAS 70/250/57.5	DF830256	70	220	250	450	57.5	7.06	I-III	1
HAS 70/500/115	DF830260	70	220	500	900	115	14.13	I-II	1.9
HAS 100/250/57.5	DF830264	100	250	250	650	57.5	4.89	I-II	1.2
HAS 100/300/57.5	DF830268	100	250	300	750	57.5	4.24	I-III	1.5
HAS 100/500/115	DF830272	100	250	500	1300	115	9.78	I-II	2.4
HAS 100/600/115	DF830276	100	250	600	1500	115	8.48	I-III	3
HAS 150/250/57.5	DF830280	150	300	250	950	57.5	3.35	I-II	1.7
HAS 150/300/57.5	DF830284	150	300	300	1150	57.5	2.76	I-II	2
HAS 150/500/115	DF830288	150	300	500	1900	115	6.69	I-II	3.4
HAS 150/600/115	DF830292	150	300	600	2300	115	5.53	I-III	4.1
HAS 200/250/57.5	DF830296	200	350	250	1250	57.5	2.54	I-III	2.2
HAS 200/300/57.5	DF830300	200	350	300	1500	57.5	2.12	I-II	2.7
HAS 200/500/115	DF830304	200	350	500	2500	115	5.09	I-III	4.5
HAS 200/600/115	DF830308	200	350	600	3000	115	4.24	I-III	5.3
HAS 250/375/115	DF830312	250	450	375	2350	115	5.41	I-II	5.3
HAS 250/400/115	DF830316	250	450	400	2500	115	5.09	I-II	5.3
HAS 250/750/200	DF830320	250	450	750	4700	200	8.18	I-III	10.7
HAS 250/750/230	DF830324	250	450	750	4700	230	10.82	I-III	10.4
HAS 250/800/230	DF830328	250	450	800	5000	230	10.17	I-II	11
HAS 300/375/115	DF830332	300	500	375	2800	115	4.54	I-II	6.1
HAS 300/400/115	DF830336	300	500	400	3000	115	4.24	I-II	6.5
HAS 300/750/230	DF830340	300	500	750	5600	230	9.08	I-III	13
HAS 300/800/230	DF830344	300	500	800	6000	230	8.48	I-II	12.9
HAS 350/500/200	DF830348	350	600	500	4400	200	8.74	I-III	11.5
HAS 350/500/230	DF830352	350	600	500	4400	230	11.56	I-III	11.5
HAS 350/600/230	DF830356	350	600	600	5300	230	9.6	I-III	13.5
HAS 350/750/230	DF830360	350	600	750	6600	230	7.71	I-III	17
HAS 350/800/230	DF830364	350	600	800	7000	230	7.27	I-III	17.7
HAS 400/500/200	DF830368	400	650	500	5000	200	7.69	I-III	13
HAS 400/500/230	DF830372	400	650	500	5000	230	10.17	I-III	13
HAS 400/600/200	DF830376	400	650	600	6000	200	6.41	I-II	14.8
HAS 400/600/230	DF830380	400	650	600	6000	230	8.48	I-III	15.2
HAS 400/750/400	DF830384	400	650	750	7500	400	20.51	I-II	18.5
HAS 400/900/400	DF830388	400	650	900	9000	400	17.09	I-III	21.7
HAS 450/600/400	DF830392	450	700	600	6800	400	22.62	I-III	15.8
HAS 450/900/400	DF830396	450	700	900	10200	400	15.08	I-II	26.1
HAS 500/600/400	DF830400	500	750	600	7500	400	20.51	I-II	17.1
HAS 500/900/400	DF830404	500	750	900	11300	400	13.61	I-II	27.3

Table 4a Standard FIBROTHAL half-cylinder designs (metric figures)

## FIBROTHAL Half-cylinders

Type designation	Part No.	Ø i.d. A [in]	Ø o.d. B [in]	Length C [in]	Power [W]	Voltage [V]	Resistance R20 [Ohm]	Terminal arr. Position	Approx. weight [lb]
HAS 70/250/57.5	DF830256	2.8	8.7	9.8	450	57.5	7.06	I-III	2.2
HAS 70/500/115	DF830260	2.8	8.7	19.7	900	115	14.13	I-II	4.2
HAS 100/250/57.5	DF830264	3.9	9.8	9.8	650	57.5	4.89	I-II	2.6
HAS 100/300/57.5	DF830268	3.9	9.8	11.8	750	57.5	4.24	I-III	3.3
HAS 100/500/115	DF830272	3.9	9.8	19.7	1300	115	9.78	I-II	5.3
HAS 100/600/115	DF830276	3.9	9.8	23.6	1500	115	8.48	I-III	6.6
HAS 150/250/57.5	DF830280	5.9	11.8	9.8	950	57.5	3.35	I-II	3.7
HAS 150/300/57.5	DF830284	5.9	11.8	11.8	1150	57.5	2.76	I-II	4.4
HAS 150/500/115	DF830288	5.9	11.8	19.7	1900	115	6.69	I-II	7.5
HAS 150/600/115	DF830292	5.9	11.8	23.6	2300	115	5.53	I-III	9.0
HAS 200/250/57.5	DF830296	7.9	13.8	9.8	1250	57.5	2.54	I-III	4.9
HAS 200/300/57.5	DF830300	7.9	13.8	11.8	1500	57.5	2.12	I-II	6.0
HAS 200/500/115	DF830304	7.9	13.8	19.7	2500	115	5.09	I-III	9.9
HAS 200/600/115	DF830308	7.9	13.8	23.6	3000	115	4.24	I-III	11.7
HAS 250/375/115	DF830312	9.8	17.7	37.5	2350	115	5.41	I-II	11.7
HAS 250/400/115	DF830316	9.8	17.7	15.7	2500	115	5.09	I-II	11.7
HAS 250/750/200	DF830320	9.8	17.7	29.5	4700	200	8.18	I-III	23.6
HAS 250/750/230	DF830324	9.8	17.7	29.5	4700	230	10.82	I-III	22.9
HAS 250/800/230	DF830328	9.8	17.7	31.5	5000	230	10.17	I-II	24.3
HAS 300/375/115	DF830332	11.8	19.7	37.5	2800	115	4.54	I-II	13.4
HAS 300/400/115	DF830336	11.8	19.7	15.7	3000	115	4.24	I-II	14.3
HAS 300/750/230	DF830340	11.8	19.7	29.5	5600	230	9.08	I-III	28.7
HAS 300/800/230	DF830344	11.8	19.7	31.5	6000	230	8.48	I-II	28.4
HAS 350/500/200	DF830348	13.8	23.6	19.7	4400	200	8.74	I-III	25.4
HAS 350/500/230	DF830352	13.8	23.6	19.7	4400	230	11.56	I-III	25.4
HAS 350/600/230	DF830356	13.8	23.6	23.6	5300	230	9.6	I-III	29.8
HAS 350/750/230	DF830360	13.8	23.6	29.5	6600	230	7.71	I-III	37.5
HAS 350/800/230	DF830364	13.8	23.6	31.5	7000	230	7.27	I-III	39.0
HAS 400/500/200	DF830368	15.7	25.6	19.7	5000	200	7.69	I-III	28.7
HAS 400/500/230	DF830372	15.7	25.6	19.7	5000	230	10.17	I-III	28.7
HAS 400/600/200	DF830376	15.7	25.6	23.6	6000	200	6.41	I-II	32.6
HAS 400/600/230	DF830380	15.7	25.6	23.6	6000	230	8.48	I-III	33.5
HAS 400/750/400	DF830384	15.7	25.6	29.5	7500	400	20.51	I-II	40.8
HAS 400/900/400	DF830388	15.7	25.6	35.4	9000	400	17.09	I-III	47.8
HAS 450/600/400	DF830392	17.7	2.80	23.6	6800	400	22.62	I-III	34.8
HAS 450/900/400	DF830396	17.7	2.80	35.4	10200	400	15.08	I-II	57.5
HAS 500/600/400	DF830400	19.7	29.5	23.6	7500	400	20.51	I-II	37.7
HAS 500/900/400	DF830404	19.7	29.5	35.4	11300	400	13.61	I-II	60.2

Table 4b Standard FIBROTHAL half-cylinder designs (imperial figures)

## Tubes

For the power connections (strip  $20 \times 3 \text{ mm}$  ( $0.79 \times 0.12 \text{ in}$ )) you can choose between radial (Design A) and face variants (Design B). Because of the high current levels a flexible wire connection is not possible.



### Type A

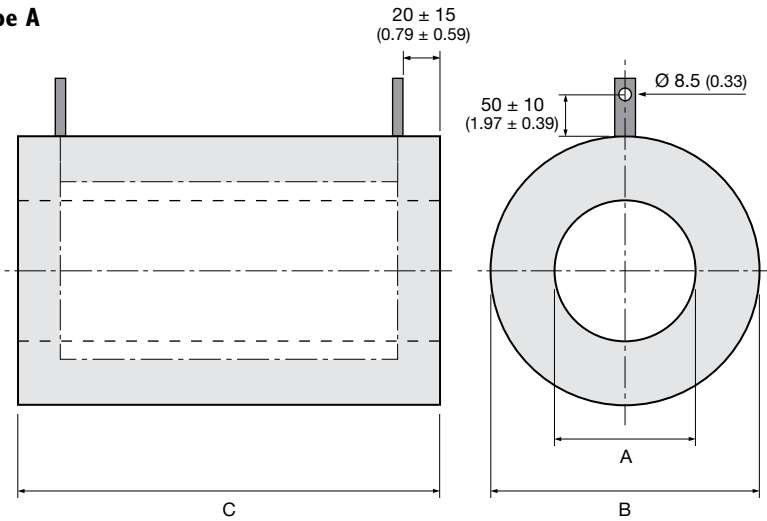

### Type B

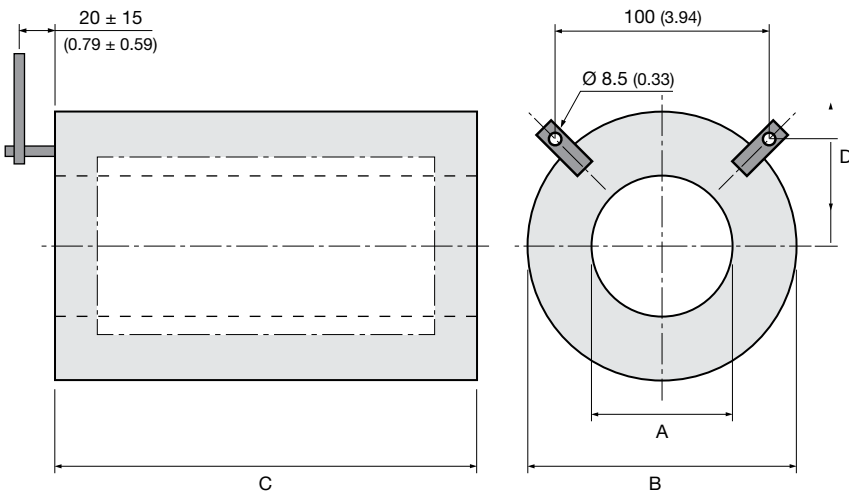

Fig. 17 FIBROTHAL standard tubes

## FIBROTHAL Tube

Type designation	Type A Part No.	Type B Part No.	Dimensions Ø i.d. A [mm]	Dimensions Ø o.d. B [mm]	Length C [mm]	Terminal arr. D [mm]	Voltage [V] Power [W] at 60 A	Voltage [V] Power [W] at 72 A	Voltage [V] Power [W] at 85 A	Resistance R20 [Ohm]	Weight [kg]
RAC 40/200	DF830147	DF830153	40	160	220	105	15.8 950	19 1369	22.5 1909	0.253	1.6
RAC 40/500	DF830158	DF830164	40	160	520	105	40 2398	48 3455	56.7 4818	0.639	3.8
RAC 70/200	DF830169	DF830175	70	240	220	135	25 1500	30 2161	35.5 3014	0.4	2.9
RAC 70/500	DF830180	DF830186	70	240	520	135	63.1 3786	75.8 5454	89.5 7608	1.008	6.9
RAC 100/200	DF830191	DF830197	100	270	220	150	34.1 2049	41 2952	48.4 4117	0.546	3.6
RAC 100/500	DF830202	DF830208	100	270	520	150	86.2 5170	103.5 7450	122.2 10391	1.377	8.5
RAC 150/200	DF830213	DF830219	150	350	220	215	49.4 2963	59.3 4269	70.1 5955	0.789	5.1
RAC 150/500	DF830224	DF830230	150	350	520	215	127 7620	152.5 10979	180.2 15314	2.03	12.5
RAC 200/200	DF830235	DF830241	200	450	220	240	64.6 3878	77.6 5587	91.7 7793	1.033	7.7
RAC 200/500	DF830246	DF830252	200	450	520	240	163.1 9787	195.8 14101	231.4 19669	2.607	18.7

Table 5a Standard FIBROTHAL tube designs (metric figures)

Type designation	Type A Part No.	Type B Part No.	Dimensions Ø i.d. A [in]	Dimensions Ø o.d. B [in]	Length C [in]	Terminal arr. D [in]	Voltage [V] Power [W] at 60 A	Voltage [V] Power [W] at 72 A	Voltage [V] Power [W] at 85 A	Resistance R20 [Ohm]	Weight [lb]
RAC 40/200	DF830147	DF830153	1.6	6.3	8.7	4.1	15.8 950	19 1369	22.5 1909	0.253	3.5
RAC 40/500	DF830158	DF830164	1.6	6.3	20.5	4.1	40 2398	48 3455	56.7 4818	0.639	8.4
RAC 70/200	DF830169	DF830175	2.8	9.4	8.7	5.3	25 1500	30 2161	35.5 3014	0.4	6.4
RAC 70/500	DF830180	DF830186	2.8	9.4	20.5	5.3	63.1 3786	75.8 5454	89.5 7608	1.008	15.2
RAC 100/200	DF830191	DF830197	3.9	10.6	8.7	5.9	34.1 2049	41 2952	48.4 4117	0.546	7.9
RAC 100/500	DF830202	DF830208	3.9	10.6	20.5	5.9	86.2 5170	103.5 7450	122.2 10391	1.377	18.7
RAC 150/200	DF830213	DF830219	5.9	13.8	8.7	8.5	49.4 2963	59.3 4269	70.1 5955	0.789	12.2
RAC 150/500	DF830224	DF830230	5.9	13.8	20.5	8.5	127 7620	152.5 10979	180.2 15314	2.03	27.6
RAC 200/200	DF830235	DF830241	7.9	17.7	8.7	9.4	64.6 3878	77.6 5587	91.7 7793	1.033	17.0
RAC 200/500	DF830246	DF830252	7.9	17.7	20.5	9.4	163.1 9787	195.8 14101	231.4 19669	2.607	41.2

Table 5b Standard FIBROTHAL tube designs (imperial figures)

## Insulating Parts

FIBROTHAL insulating parts are available in the same standard dimensions as the heating modules. The standard range also includes insulating end pieces which fit the outside diameters of the half-cylinders and tubes. If necessary these end pieces can also be supplied drilled to the size of the work tube. The standard thickness is 125 mm (4.92 in) or 50 mm (1.97 in); other dimensions are also available.

### FIBROTHAL End Piece Range

Outside diameter		Thickness		Weight	
[mm]	(in)	[mm]	(in)	[kg]	(lb)
160	(6.3)	125/50	(4.9/2.0)	0.5	(1.1)
220	(8.7)	125/50	(4.9/2.0)	0.9	(2.0)
240	(9.5)	125/50	(4.9/2.0)	1.1	(2.4)
300	(11.8)	125/50	(4.9/2.0)	1.2	(2.6)
350	(13.8)	125/50	(4.9/2.0)	2.4	(5.3)
450	(17.7)	125/50	(4.9/2.0)	3.9	(8.6)
500	(19.7)	125/50	(4.9/2.0)	4.9	(10.8)
600	(23.6)	125/50	(4.9/2.0)	7.0	(15.4)
650	(25.6)	125/50	(4.9/2.0)	8.2	(18.1)
700	(27.6)	125/50	(4.9/2.0)	9.6	(21.2)
750	(29.5)	125/50	(4.9/2.0)	11.0	(24.3)

Table 6 FIBROTHAL standard KANTHAL end pieces

# Modules to Special Design

Over and above the standard range we offer an extensive special range of different heating systems. With these, all furnace sizes and designs can, in principle, be created. The following systems are available:

- Module with embedded heating
- ROB in panel and shell design
- Meander systems
- Special tube modules
- Muffles
- Insulating parts

An extensive range of forming moulds are available for the manufacture of special modules. For special designs a portion of the mould costs may be charged.

## Modules with Embedded Heating

These modules can be used for almost all furnace layouts. In addition to panels for furnaces with flat walls we manufacture many different module designs for cylindrical surfaces, such as tubes up to 500 mm (19.7 in) diameter and half-cylinders up to 650 mm (25.6 in) diameter. For larger inside diameters, shell modules (1/3, 1/4, 1/6 shells, etc.) are used. The designs correspond to that of the standard panels or half-cylinders. The maximum element temperature is 1150°C (2100°F).

### Advantages of this system:

- The heating element is directly incorporated into the module and requires no additional mountings
- Shape, dimensions and electrical data variable within wide limits
- Terminal voltages of the modules correspond to line voltage or fractions of it
- Easy replacement of the modules, if the furnace is suitably designed, even during operation
- No limitation on the installation position



## ROB in Panel and Shell Design

The ROB system consists of FIBROTHAL insulation modules with built-in mounting system and meander-shaped heating elements of round wire, the element legs mainly running next to each other in V-form. Both KANTHAL and NIKROTHAL® alloys can be used here.

### General ROB advantages:

- Free-radiating heating element up to 1300°C (2370°F) element temperature
- Heating element change possible
- Long heating element length over several modules possible, therefore far fewer terminals are required
- Larger heating conductor cross-section can be installed; this results in longer element working life
- High power concentrations can be installed (see Fig. 12)

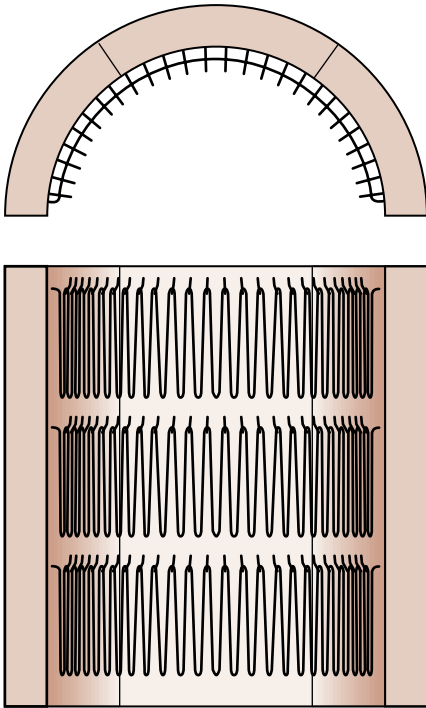

Fig. 18 ROB in panel design

## Meanderthal II

The heating element mountings consist of metallic hairpin-shaped parts, which are anchored in the ceramic fiber module.

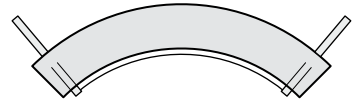
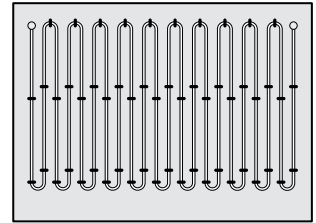
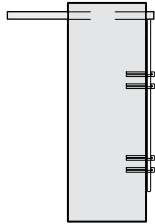
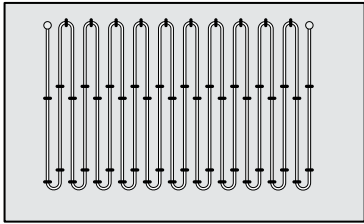

Fig. 19 Meanderthal II modules

### Specific advantages:

- No limitation on the installation position; also suitable for tilting furnaces
- Variable heating element pitch value
- Also suitable for round furnaces

## Meanderthal III

The heating element mountings consist of metallic rod support and metallic holders, anchored in the ceramic fiber module. (Meanderthal III replaces an earlier design called Meanderthal I).

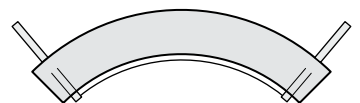
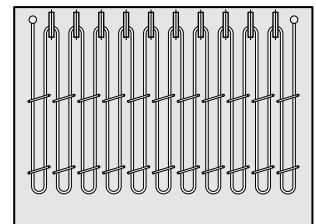
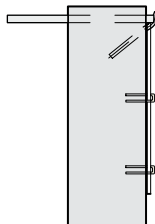
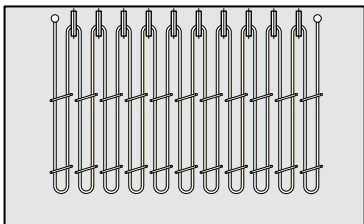

Fig. 20 Meanderthal III modules

### Specific advantages:

- Elements can be replaced
- Tilting of furnace up to 90°C (195°F) is possible
- Also suitable for round furnaces

## Special Tube Modules

These modules, usually multi-zone, correspond in their design to the RAC tubes (see Principle II, Fig. 14). The maximum inside diameter is 400 mm (15.7 in); lengths up to approx. 2000 mm (78.7 in) can be manufactured. If required these heating tubes can also be supplied with a sheet metal shell. Depending on the requirements the alloys KANTHAL A-1, AF or APM are used.

### Advantages of the system:

- High temperature uniformity
- Precise temperature profiles can be achieved
- High power concentration (see Fig. 12)
- Can be installed in any position



Fig. 21 Heating cassette (diffusion annealing tube)

## Muffles

Monoblock ceramic fiber modules with embedded heating element, can be used for laboratory and small chamber furnaces. These can be heated on up to four sides. Maximum element temperature 1150°C (2100°F). Matching door modules can be supplied.

### Advantages of the system:

- Short assembly times
- Short heating up times
- Uniform temperature distribution in the furnace interior
- Rapidly and easily replaced

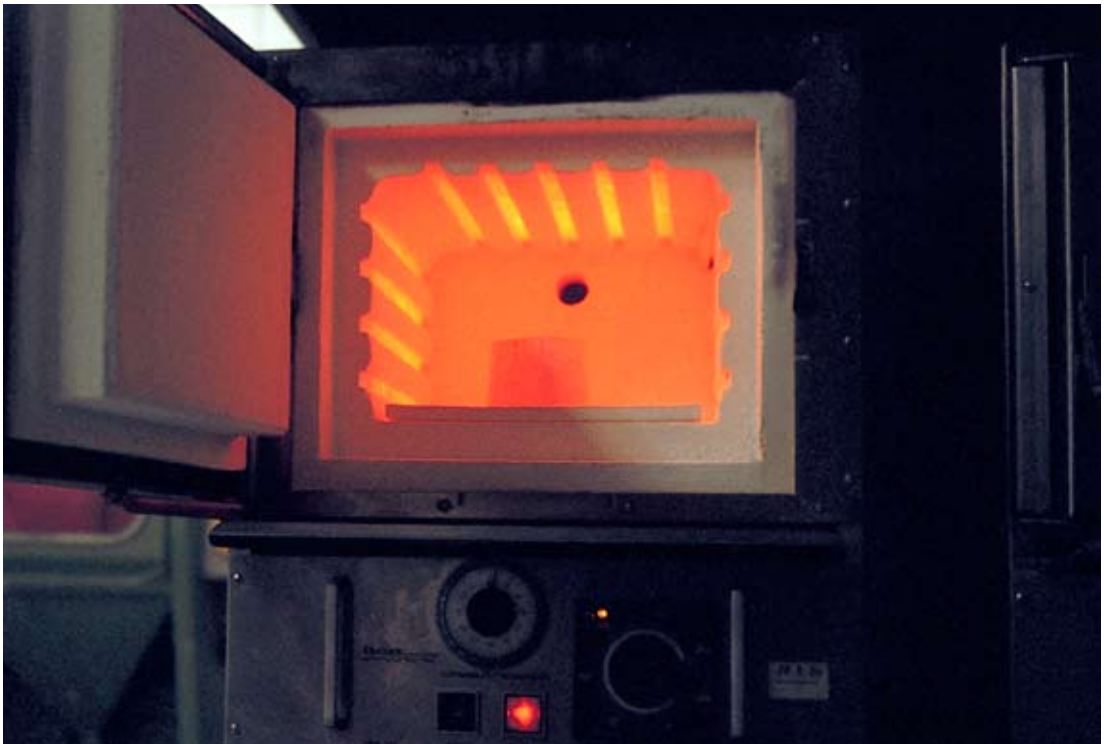

Fig. 22 FIBROTHAL muffle in laboratory furnace

## Insulating Parts

Insulating parts to special designs can be supplied in the same dimensions as the heating modules described in the preceding section.

### FibroSiC, unsupported roof modules

The further development of our FIBROTHAL system, in particular with the objective of achieving self-supporting, easy-to-assemble roof insulation, has led to the combination of ceramic fiber insulation modules and SiC tubes.

This design, introduced under the type designation FibroSiC, can be used for spans up to 2200 mm (86.6 in) at  $T_f = 1200^\circ\text{C}$  (2190°F).

### Advantages of the system:

- Unsupported up to 2200 mm (86.6 in) at furnace temperature  $1200^\circ\text{C}$  (2190°F)
- Easy to assemble
- Economic design, since no other roof support is needed

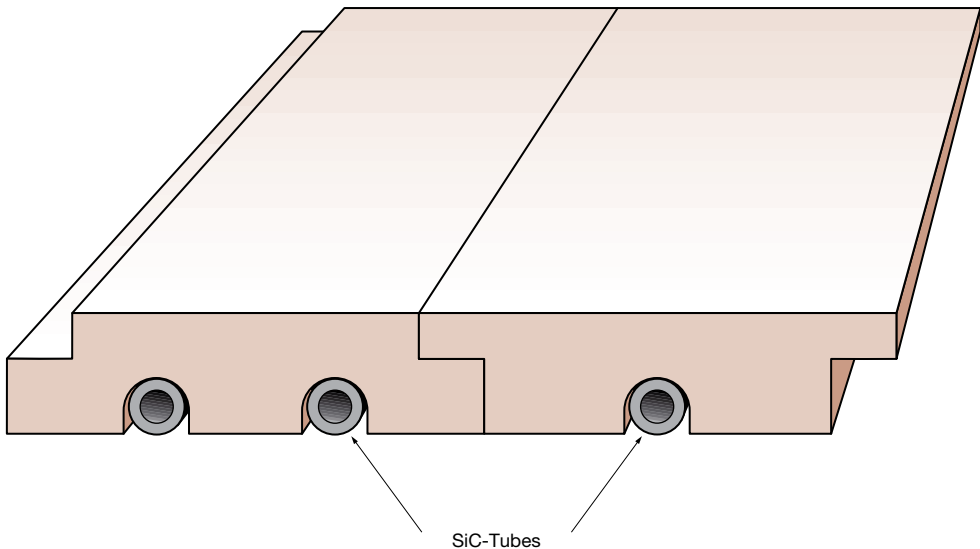

Fig. 23 FibroSiC

# Accessories

## Flexible Bead-Insulated Connecting Leads

### Only for modules with embedded heating!

The lead consists of NIKROTHAL 40 and is multi-twisted. The choice of the necessary cross-section depends on the power consumption of the FIBROTHAL module. The diagrams below can be used to select the correct lead dimensions. Remember, however, that the temperatures at the terminals must never exceed 200°C (390°F).

It is also necessary to note that the temperature of the lead in the back insulation, in particular the welded connection to the terminal, should not exceed 800°C (1470°F). The lead temperature is due to the combination of inherent heating caused by the passing current (see Figs. 24 and 25) and the temperature of the insulation.

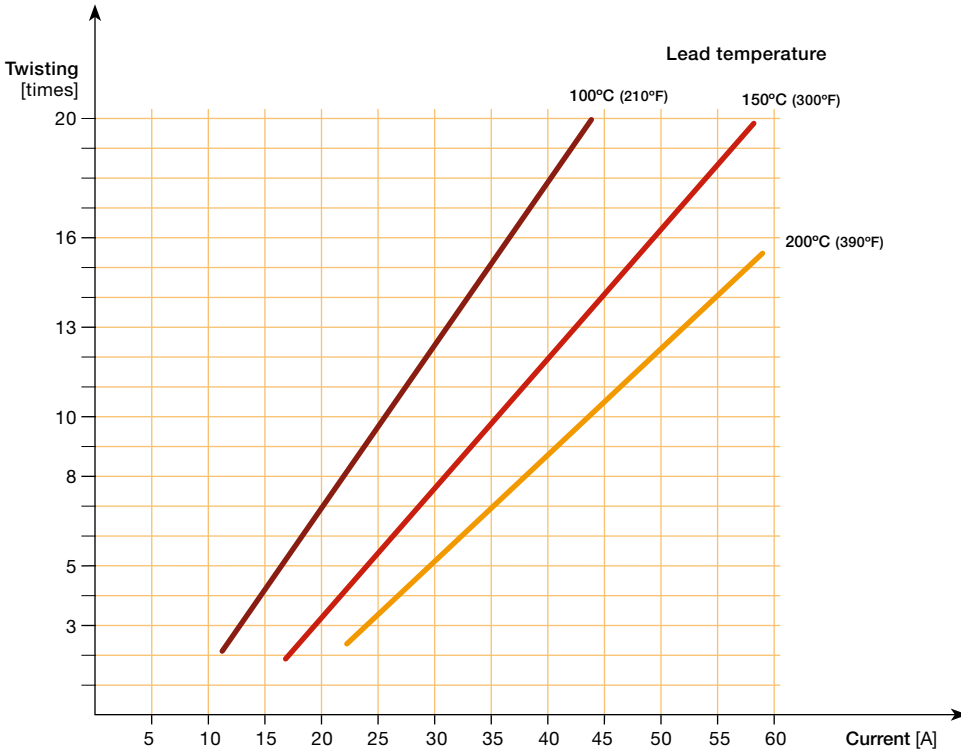

Fig. 24 Leads bead-insulated in air

Outside diameter [mm]	Number of twists [x times]					
	3.0	5.0	6.0	8.0	10.0	13.0
Twisted lead	3.5	4.5	5.0	6.5	7.0	8.5
Insulating beads	11.0	11.0	11.0	14.0	14.0	14.0

Table 7a Twisted connecting leads (metric figures)

Outside diameter [in]	Number of twists [x times]					
	3.0	5.0	6.0	8.0	10.0	13.0
Twisted lead	0.14	0.18	0.20	0.26	0.28	0.33
Insulating beads	0.43	0.43	0.43	0.55	0.55	0.55

Table 7b Twisted connecting leads (imperial figures)

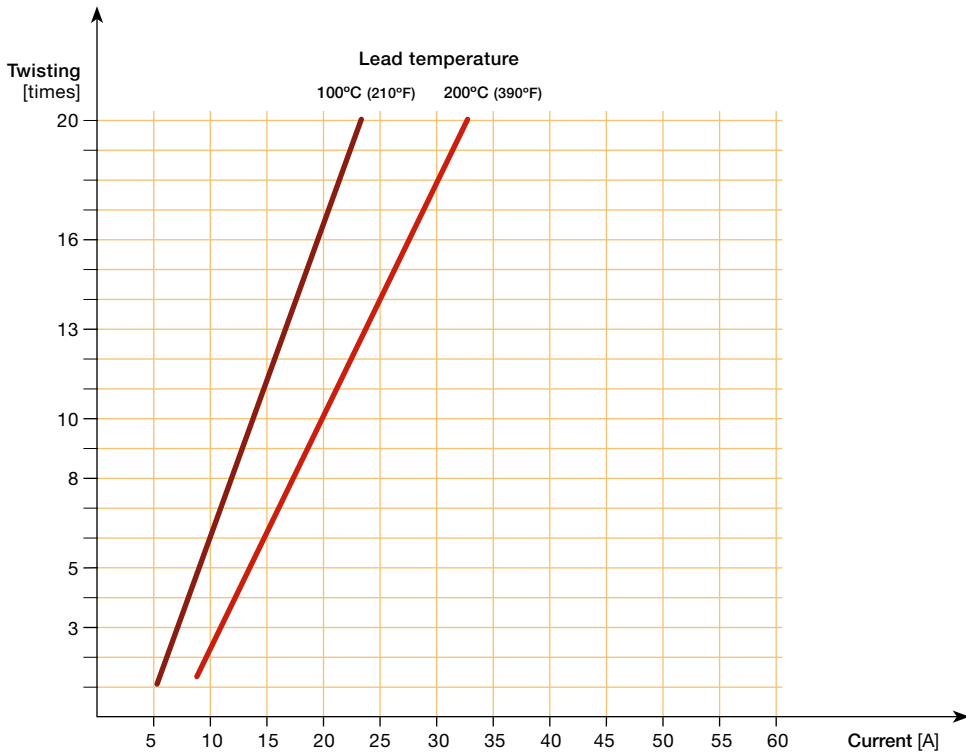

Fig. 25 Leads bead-insulated in FIBROTHAL

**FIBROTHAL Insulating Blankets**

For compensating for module and furnace tolerances and shrinkage, dimensions: 6.35 × 300 mm (0.25 × 11.8 in) wide.

**Protection Tubes for Thermocouples**

Diameter 7/5 mm (0.28/0.20 in) × desired length, both ends open.

**FIBROTHAL Glue**

For bonding FIBROTHAL modules together.

**FIBROTHAL Hardener**

For hardening machined surfaces.

**FIBROTHAL Cement**

For patching up damaged FIBROTHAL modules.

**FIBROTHAL Repair Kit**

Consisting of: FIBROTHAL adhesive, hardener, powder, wool and felt.

**FIBROTHAL Mounting**

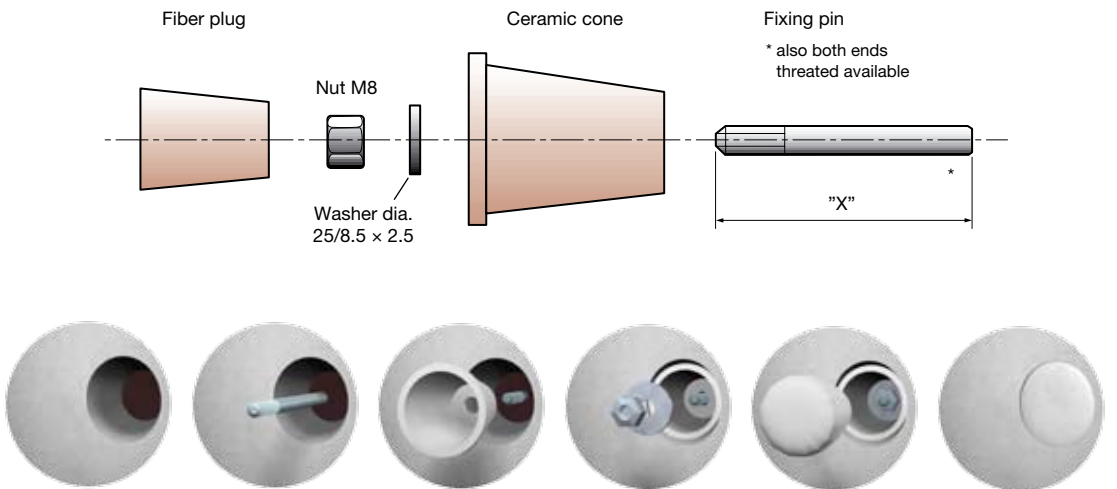
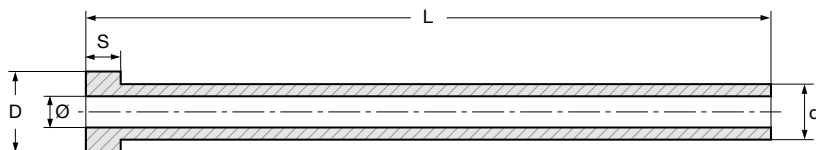

Fig. 26 FIBROTHAL mountings



## Ceramic Tubes with Flange



Ref.	D		d		Ø		S		L stock	
	[mm]	(in)	[mm]	(in)	[mm]	(in)	[mm]	(in)	[mm]	(in)
TUT-20-10	20	(0.79)	10	(0.39)	6	(0.24)	6	(0.24)	max 300	(max 11.8)
TUT-25-15	25	(0.98)	15	(0.59)	9	(0.35)	10	(0.39)	100-150-200-300	(3.9-5.9-7.9-11.8)
TUT-30-20	30	(1.18)	20	(0.79)	12	(0.47)	15	(0.59)	100-150-200-300	(3.9-5.9-7.9-11.8)
TUT-35-25	35	(1.38)	25	(0.98)	15	(0.59)	20	(0.79)	150-200-300	(5.9-7.9-11.8)
TUT-40-30	40	(1.57)	30	(1.18)	15	(0.59)	20	(0.79)	200-250-300	(7.9-9.8-11.8)
TUT-45-35	45	(1.77)	35	(1.38)	20	(0.79)	20	(0.79)	150-200-300	(5.9-7.9-11.8)
TUT-50-40	50	(1.97)	40	(1.57)	25	(0.98)	30	(1.18)	300	(11.8)

Dimensional tolerances according DIN 40680 norms  
 Usually manufactured in mat. A38E  
 Bold stock standard

Table 8 Ceramic tubes with flange

## Ceramic Insulators and Plugs

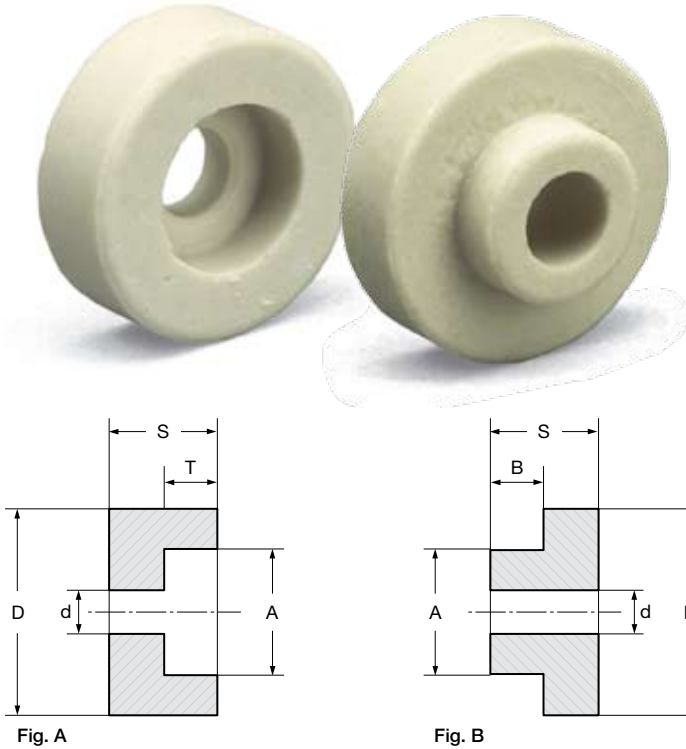

Code	Ref.	Fig.	D [mm] (in)	d [mm] (in)	A [mm] (in)	T [mm] (in)	B [mm] (in)	S [mm] (in)	Mat.
ISM	025-16,5-5 M	B	15.5 (0.61)	5 (0.20)	10 (0.39)	– –	1.5 (0.06)	6 (0.24)	Steatite
ISF	025-16,5-5 F	A	15.5 (0.61)	5 (0.20)	11 (0.43)	1.8 (0.07)	– –	5 (0.20)	Steatite
ISM	025-22-6.5 M	B	22.5 (0.89)	6.5 (0.26)	11.5 (0.45)	– –	4 (0.16)	10.5 (0.41)	Steatite
ISF	025-22-6.5 F	A	22.5 (0.89)	6.5 (0.26)	12.3 (0.48)	4.3 (0.17)	– –	8 (0.31)	Steatite
ISM	025-30-8 M	B	30 (1.18)	8.5 (0.33)	16 (0.63)	– –	7.5 (0.30)	15 (0.59)	Steatite
ISF	025-30-8 F	A	30 (1.18)	8.5 (0.33)	18 (0.71)	8.5 (0.3)	– –	15 (0.59)	Steatite
TAP	025-23-7	B	23 (0.91)	7 (0.28)	13 (0.51)	– –	15 (0.59)	20 (0.79)	A38E
TAP	025-45-13	B	45 (1.77)	13 (0.51)	26 (1.02)	– –	18 (0.71)	30 (1.18)	A42P
TAP	025-60-15	B	60 (2.36)	15 (0.59)	30 (1.18)	– –	18 (0.71)	40 (1.57)	A42P

Dimensional tolerances according DIN 40680 norms  
 Bold stock standards

Table 9 Ceramic insulators and plugs

# Assembly

For relatively small furnaces, such as tube furnaces with RAC modules, FIBROTHAL half-cylinders or third cylinders and muffle or chamber furnaces with FIBROTHAL panel modules, usually no special measures are necessary for the mounting or fixing of FIBROTHAL modules, because they are self-supporting and/or self-stabilising inside the furnace body.

## Attaching FIBROTHAL Modules

For attaching FIBROTHAL modules in larger furnace installations, we recommend FIBROTHAL mounting (see Accessories). For certain furnace designs it is possible to use a minimum of mountings, sometimes even none, because the modules support each other in a similar way as the blocks of a vault.

Examples of this are shown in Figs. 27, A to C. With this assembly it is essential that the modules can be

assembled or inserted from the outside or from above. To reduce the assembly times and therefore costs, we can supply completely pre-assembled module rings.

If the design makes assembly of the modules from the furnace interior necessary, we recommend the tried and tested module combination as per Fig. 27, D.

This design consists of the module types A + B, in which the modules "A" are held by the modules "B". In most cases it is sufficient to fix the modules "B" with the mountings.

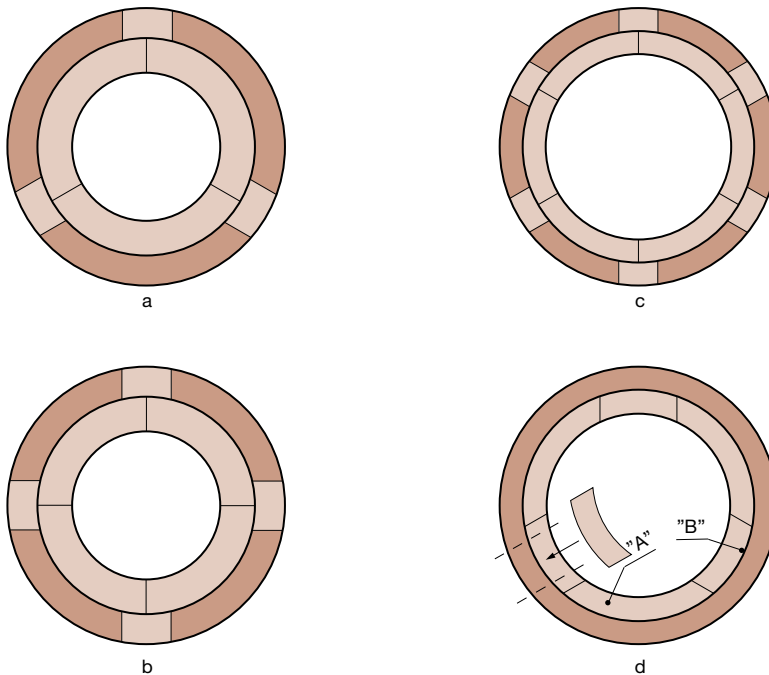
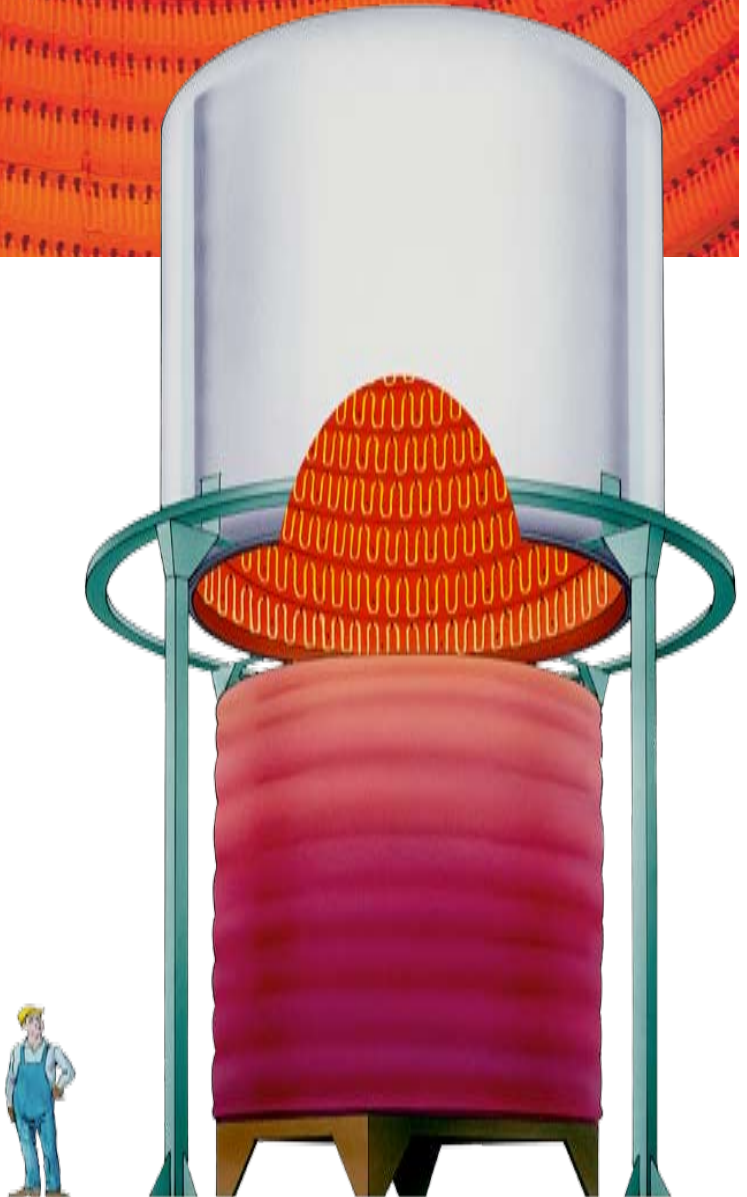

Fig. 27 Module installation situations A–D



Fig. 28 ROB-modules in a bell furnace



## Sealing the Joints

To compensate for furnace and module tolerances, and for shrinkage of the module inside, but also to prevent radiation losses through the module gaps, we recommend fitting a double folded layer of ceramic fiber felt (see accessories) between FIBROTHAL modules. The ceramic fiber felt should project by at least 25 mm (0.98 in) from the front of the module. This projection serves to compensate for the thermal module shrinkage.

## Welding on the Heating Element

If welding has to be carried out, e.g. between the terminal and the heating element, we recommend using the TIG method. Welding filler is usually not necessary. Please follow our welding instructions.

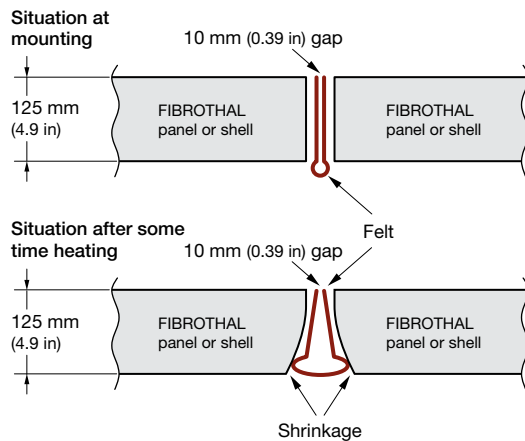

Fig. 29 Fitting of fiber felt (principle)



Fig. 30 Assembly of FIBROTHAL ROB-segments for a vacuum purge furnace

# Overview of the Heating Systems

The table below is intended for quick reference to the various heating systems.

	FIBROTHAL Panels embedded	FIBROTHAL Shells embedded	FIBROTHAL Tubes embedded	RAC	R O B	Meanderthal System II	Meanderthal System III
Vertical installation	X	X	X	X	X	X	X
Horizontal installation	XD	XD	X	X	–	X	O
Floor installation	X	X	n.a.	n.a.	X	X	O
Suitable for round furnaces	O	X	X	X	X	X	X
Element change possible	–	–	–	–	X	–	X
Free-radiating heating	–	–	–	X	X	X	X
Element quality A-1	X	X	X	X	X	X	X
AF	–	–	–	X	X	X	X
APM	–	–	–	X	X	X	X
N80/N60	–	–	–	–	X	X	X
Max. element temp. A-1, AF, APM [°C] (°F)	A-1 1150 (2100)	A-1 1150 (2100)	A-1 1150 (2100)	1300 (2370)	1300 (2370)	AF 1250 (2280) A-1 1300 (2370) APM 1400 (2550)	AF 1250 (2280) A-1 1300 (2370) APM 1400 (2550)
Max. element temp. N80/N60 [°C] (°F)	–	–	–	–	1100/1050 (2010/1920)	1100/1050 (2010/1920)	1100/1050 (2010/1920)

- X = possible
- D = pin system recommended in certain circumstances
- O = sometimes possible (customer information necessary)
- = not possible
- n.a. = not applicable

Table 10 Selection criteria for heating systems



Fig. 31 FIBROTHAL modules in a suspended monorail furnace





# Voltage and Power Conversion for Standard Modules

## Calculation Example

### Assumption

For a chamber furnace 6 FIBROTHAL heating panels with dimensions  $750 \times 450 \times 125$  mm ( $29.5 \times 17.7 \times 4.9$  in) are necessary. The required furnace should have a power rating of approx. 25 kW.

For this duty FIBROTHAL heating module PAS 750/450/230 (Table 3) can be chosen. According to the Table the standard data are 5400 W at 230 V supply voltage with a cold resistance of 9.42 Ohms (hot resistance approx. 4% higher = 9.8 Ohms). 6 heating modules would therefore give a total installed furnace power of 32.4 kW (2 three-phase groups; star connection).

## Calculation of the Modified Power per FIBROTHAL Heating Panel

$$\text{Power per heating panel (P)} = \frac{\text{required furnace power (P)}}{\text{quantity of Heating Modules}}$$

$$\text{Power per heating panel (P)} = \frac{25 \text{ (kW)}}{6} = 4170 \text{ (W)}$$

## Calculation of the New Supply Voltage U

$$U = \sqrt{P \cdot R_w}$$

$$U = \sqrt{4170 \text{ (W)} \cdot 9.8 \text{ (\Omega)}} = 202.15 \text{ (V)}$$

$$U = 202.15 \text{ Volts}$$

In this case it is advisable to select 1 three-phase group in delta connection with two heating modules in series, i.e. each module is connected to 200 V.

## Calculation of the Power P per FIBROTHAL Heating Module at 200 Volts Supply Voltage

$$P = \frac{U^2}{R_w}$$

$$\frac{200^2 \text{ (V}^2\text{)}}{9.8 \text{ (\Omega)}} = 4082 \text{ (W)}$$

$$P = 4082 \text{ Watts}$$

The total furnace power is therefore  $6 \times 4082 \text{ W} = 24489 \text{ W}$ .

The temperature factor which contributes to the change in the heating resistance can be neglected for the calculation illustrated above, because with the element alloy KANTHAL A-1 it is max. 4%.

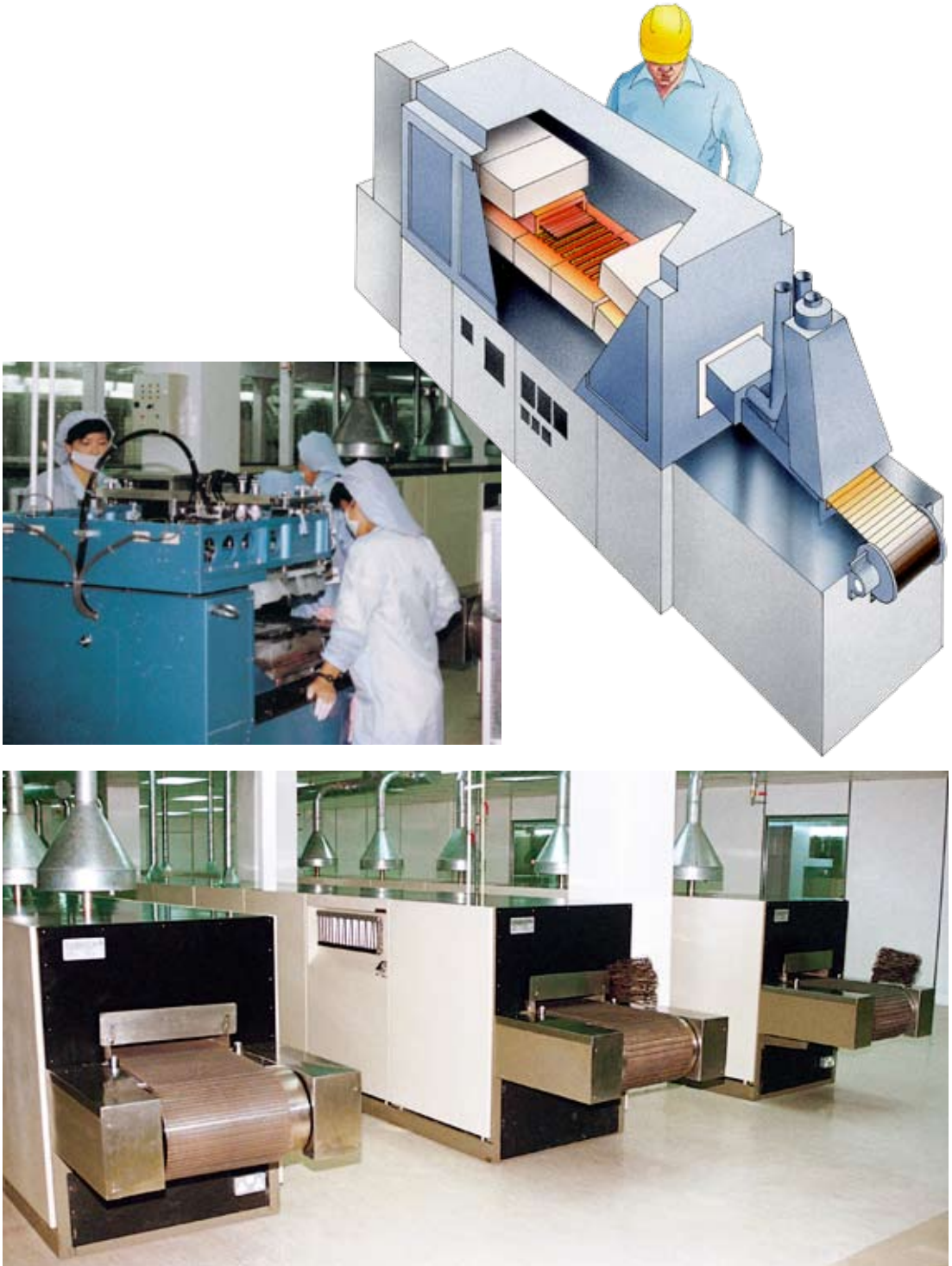

Fig. 32 FIBROTHAL modules used in a conveyor belt furnace

## **Kanthal – a World-Renowned Name Within the Field of Electric Heating**

Since the early thirties, Kanthal has developed market leading, electric resistance alloy products and materials.

Our R&D efforts have always been directed at improving our materials to function fully at ever higher temperatures.

The center for production, product development and metallurgy is in Hallstahammar, Sweden, whilst sales and production finishing plants are located around the world, close to our customers and operated through our subsidiaries and local representatives.

## **Kanthal – a Member of the Sandvik Group**

The Sandvik Group is a global high technology enterprise with 47,000 employees and annual sales of approximately SEK 86 billion. Sandvik spends about 4 percent of its turnover on research and development.

As a member of the Sandvik Group, Kanthal has full access to world-class competence within materials and process technology, as well as Sandvik's R&D-center in Sweden, which is one of the most distinguished in the world. Through Sandvik's global sales organization Kanthal is represented in 130 countries.



*Kanthal – Head office and main facility in Hallstahammar, Sweden*

# Kanthal Sales and Service All Over the World

## EUROPE

### Bulgaria

Kanthal Representative Office  
SOFIA  
Phone +359 2 870 4297  
Fax +359 2 297 14813

### Denmark

Kanthal AB  
BRØNDBY  
Phone +45 4346 5270  
Fax +45 4346 5271

### England

Kanthal Ltd.  
STOKE-ON-TRENT  
Phone +44 1782 224 800  
Fax +44 1782 224 820

### Finland

Sandvik Mining and Construction Oy - Kanthal  
VANTAA  
Phone +358 20 544 121  
Fax +358 20 544 5199

### France

Sandvik SAS - Division Kanthal  
COLOMBES  
Phone +33 1 4786 5660  
Fax +33 1 4781 5661

### Germany

Kanthal ZN der Sandvik GmbH  
MOERFELDEN-WALLDORF  
Phone +49 6105 40010  
Fax +49 6105 400188

### Italy

Sandvik Italia S.p.A - Divisione Kanthal  
MILANO  
Phone +39 02 307 051  
Fax +39 02 300 98605

### Norway

Kanthal AB  
LILLESTRØM  
Phone +47 6484 3560  
Fax +47 6484 3565

### Poland

Sandvik Polska Sp. z o.o. - Kanthal  
WARSAW  
Phone +48 22 647 3880  
Fax +48 22 843 0588

### Russia

OAO Sandvik - MKTC  
MOSCOW  
Phone +7 495 689 8385  
Fax +7 495 745 8720

### Scotland

Kanthal Ltd.  
PERTH  
Phone +44 1738 493 300  
Fax +44 1738 493 301

### Spain

Sandvik Española S.A. - Kanthal Division  
MARTORELLES  
Phone +34 93 571 7540  
Fax +34 93 571 7586

### Sweden

Kanthal AB  
HALLSTAHAMMAR  
Phone +46 220 21000  
Fax +46 220 16350

### Turkey

Sandvik Endüstriyel Mamüller San. ve Tic. A.Ş.  
KARTAL-İSTANBUL  
Phone +90 216 453 0780  
Fax +90 216 453 0707

## NORTH & SOUTH AMERICA

### United States

Kanthal Corporation  
BETHEL, CT  
Phone +1 203 744 1440  
Fax +1 203 743 2547

Kanthal Heating Systems  
AMHERST, NY  
Phone +1 716 691 4010  
Fax +1 716 691 7850

Kanthal Palm Coast  
PALM COAST, FL  
Phone +1 386 445 2000  
Fax +1 386 446 2244

MRL Industries Inc.  
SONORA, CA  
Phone +1 209 533 1990  
Fax +1 209 533 4079

### Brazil

Sandvik do Brasil S.A. - Kanthal  
VINHEDO  
Phone +55 19 3826 7400  
Fax +55 19 3826 7416

## ASIA

### China

Kanthal China (Shanghai office)  
C/o Sandvik Int. Trading Co., Ltd.  
SHANGHAI  
Phone +86 21 5869 8969  
Fax +86 21 5869 6155

### Hong Kong

Sandvik HongKong Ltd. -  
Business Area Kanthal  
KOWLOON  
Phone +852 2735 0933  
Fax +852 2735 7238

### India

Sandvik Asia Ltd. - Kanthal  
TAMIL NADU  
Phone +91 4344 279 559  
Fax +91 4344 277 244

### Japan

Sandvik KK - Kanthal Division  
TOKYO  
Phone +81 3 6420 1070  
Fax +81 3 6420 1071

### Singapore

Kanthal Electroheat (SEA) Pte. Ltd.  
SINGAPORE  
Phone +65 6 477 3742  
Fax +65 6 477 3744

### South Korea

Kanthal in Korea  
C/o Sandvik Korea Ltd.  
SEOUL  
Phone +82 2 369 0835  
Fax +82 2 761 0435

## OCEANIA

### Australia

Sandvik Australia - Kanthal Division  
DANDENONG  
Phone +61 3 9238 7216  
Fax +61 3 9238 7165

### New Zealand

Sandvik New Zealand Ltd.  
AUCKLAND  
Phone +64 9 2735 888  
Fax +64 9 2735 897

## AFRICA

### South Africa

Kanthal Southern Africa (Pty) Ltd.  
EAST RAND  
Phone +27 11 421 5779  
Fax +27 11 421 3384

# KANTHAL

Kanthal – a Sandvik brand

Kanthal AB, Box 502, SE-734 27 Hallstahammar, Sweden Phone +44 220 21000 Fax +46 220 21166 www.kanthal.com