

Motors and motor controllers

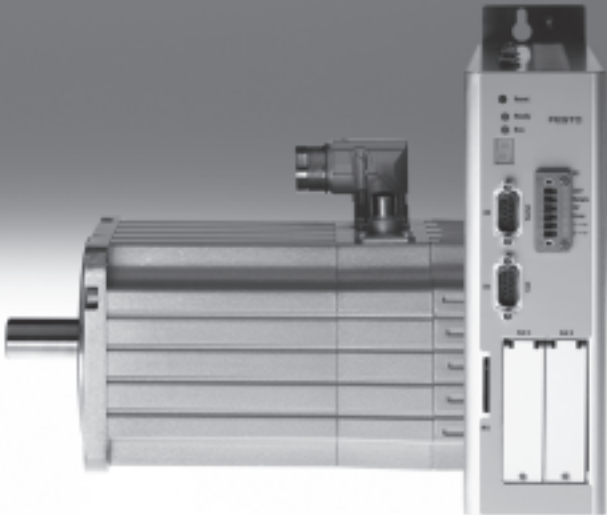

Motors and motor controllers

Table of contents

FESTO

Stepper motors EMMS-ST	
Key features	4
Type codes	5
Technical data	6
Accessories	13
Motor controllers CMMS-ST, for stepper motors	
Key features	16
Type codes	18
Technical data	19
Accessories	22
Servo motors EMMS-AS	
Key features	26
Type codes	27
Technical data	28
Accessories	36
Motor controllers CMMS-AS, for servo motors	
Key features	40
Type codes	42
Technical data	43
Accessories	47
Motor controllers CMMP-AS, for servo motors	
Key features	50
Type codes	52
Technical data	53
Accessories	58
Motor units MTR-DCI	
Key features	62
Type codes	63
Technical data	64
Ordering data	69
Accessories	70



Stepper motors EMMS-ST

Key features

Everything from a single source

Stepper motors EMMS-ST

→ 6



- 2-phase hybrid technology
- Optionally integrated encoder for “Servo Lite operation” (closed loop)
- Sinusoidal current impressing
- Optionally with holding brake
- Protection class: IP54

Gear unit EMGA-SST

→ 13



- Planetary gear unit
- Gear unit ratio $i = 3$ and 5 , available ex-stock
- Further designs and gear ratios on request
- Life lubrication
- Protection class: IP54

Motor controller CMMS-ST

→ 19



- Positioning controller with setpoint specifications for positions, rotational speed and torque
- “Servo Lite operation” (closed loop) with encoder option, in other words no step losses, current following errors are corrected
- Interfaces:
 - I/O interface
 - CANopen
 - Profibus DP
 - DeviceNet

Power supply units SVG

→ Internet: svg



- Robust hardware
- Input voltage 230 V AC / 115 V AC
- Output voltage 24, 48 V DC
- Output current 5, 10, 20 A

Motor and encoder cables NEBM

→ 14



- Screened cables
- Suitable for chain link trunking
- Protection class IP67

Axial kits EAMM

→ Internet: eamm



- Specified kits for all electromechanical axes from Festo

Stepper motors EMMS-ST

Type codes

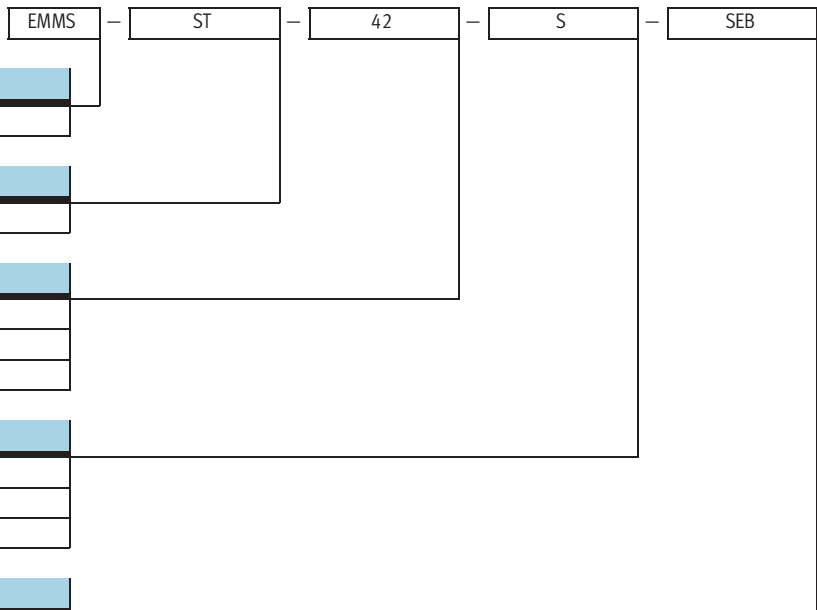

Type

EMMS	Motor
------	-------

Motor type

ST	Stepper motor
----	---------------

Flange dimensions

42	42 mm
57	57 mm
87	87 mm

Gradation of the overall length

S	Small
M	Medium
L	Large

Additional function

S	Straight connection
E	Encoder
B	Brake

Stepper motors EMMS-ST

Technical data

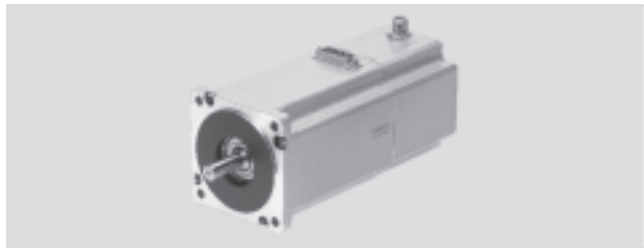

General technical data		
Size		42
Motor		
Nominal voltage	[V DC]	48
Nominal current	[A]	1.8
Holding torque	[Nm]	0.5
Stepper angle	[°]	1.8 ±5%
Winding resistance	[Ω]	1.75 ±10%
Winding inductance	[mH]	5.4
Drive mass moment of inertia	[kgcm ²]	0.082/0.095 ¹⁾
Radial load on shaft	[N]	20
Axial load on shaft	[N]	7
Mass moment of inertia of rotor	[kgcm ²]	0.082
Brake		
Operating voltage	[V DC]	24 ±10%
Output	[W]	8
Holding torque	[Nm]	0.4
Mass moment of inertia	[kgcm ²]	0.013

1) With brake

Size		57-S	57-M
Motor			
Nominal voltage	[V DC]	48	
Nominal current	[A]	5	
Holding torque	[Nm]	0.8	1.4
Stepper angle	[°]	1.8 ±5%	
Winding resistance	[Ω]	0.15 ±10%	0.25 ±10%
Winding inductance	[mH]	0.5	0.95
Drive mass moment of inertia	[kgcm ²]	0.29/0.30 ¹⁾	0.48/0.5 ¹⁾
Radial load on shaft	[N]	52	
Axial load on shaft	[N]	10	
Mass moment of inertia of rotor	[kgcm ²]	0.29	0.48
Brake			
Operating voltage	[V DC]	24 ±10%	
Output	[W]	8	10
Holding torque	[Nm]	0.4	1
Mass moment of inertia	[kgcm ²]	0.01	0.02

1) With brake

Stepper motors EMMS-ST

Technical data

FESTO

General technical data				
Size		87-S	87-M	87-L
Motor				
Nominal voltage	[V DC]	48		
Nominal current	[A]	9.5		
Holding torque	[Nm]	2.5	5.9	9.3
Stepper angle	[°]	1.8 ±5%		
Winding resistance	[Ω]	0.1 ±10%	0.23 ±10%	0.23 ±10%
Winding inductance	[mH]	0.45	2.6	2.7
Drive mass moment of inertia	[kgcm ²]	1/1.07 ¹⁾	1.9/1.97 ¹⁾	3/3.07 ¹⁾
Radial load on shaft	[N]	200		
Axial load on shaft	[N]	65		
Mass moment of inertia of rotor	[kgcm ²]	1	1.9	3
Brake				
Operating voltage	[V DC]	24 ±10%		
Output	[W]	11		
Holding torque	[Nm]	2		
Mass moment of inertia	[kgcm ²]	0.07		

1) With brake

Technical data – Encoder		
Encoder, optical		
Operating voltage	[V DC]	5
Pulses/revolution	[rpm]	500
Zero pulse		Yes
Line driver		RS422 protocol

Weight [g]						
Size	42	57-S	57-M	87-S	87-M	87-L
Product weight	360	870	1,100	1,950	3,050	4,200
With encoder	450	970	1,200	2,100	3,200	4,350
With brake	540	1,090	1,320	2,350	3,450	4,600
With encoder and brake	600	1,150	1,380	2,500	3,600	5,000

Operating and environmental conditions	
Insulation protection class to VDE 60034	B
Protection class: motor shaft	IP54
Protection class: motor housing with connection technology	IP54
Ambient temperature	[°C] -10 ... +50
Storage temperature	[°C] -20 ... +70
CE mark (see declaration of conformity)	In accordance with EU EMC directive
Relative air humidity (non-condensing)	[%] 45 ... 80

Stepper motors EMMS-ST

Technical data

Pin allocation

Motor connection

Size 42, 57

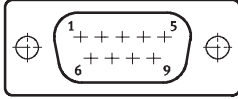

PIN	Function
1	String A
2	String A/
3	String B
4	String B/
5	-
6	-
7	Brake (24 V)
8	Brake (0 V)
9	-

Size 87

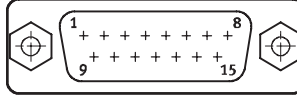

PIN	Function
1	String A
2	String A
3	String A/
4	String A/
5	String B
6	String B
7	String B/
8	String B/
9	-
10	-
11	Brake (24 V)
12	Brake (0 V)
13	-
14	-
15	-

Encoder connection

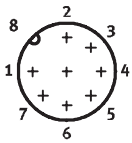

PIN	Function
1	Signal trace A
2	Signal trace A/
3	Signal trace B
4	Signal trace B/
5	0 V
6	Signal trace N
7	Signal trace N/
8	5 V

Stepper motors EMMS-ST

Technical data

FESTO

Torque M as a function of rotational speed n

EMMS-ST-42

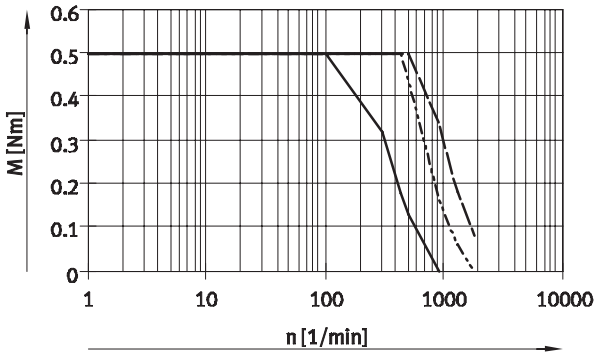

EMMS-ST-57-S

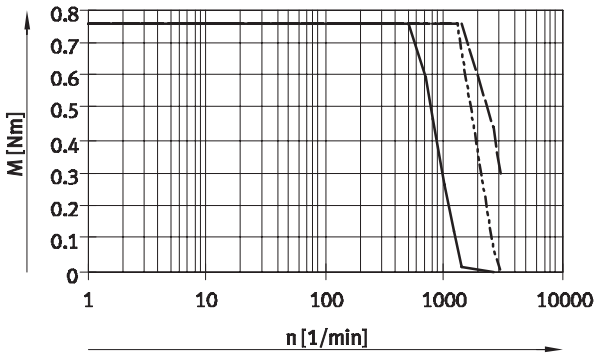

EMMS-ST-57-M

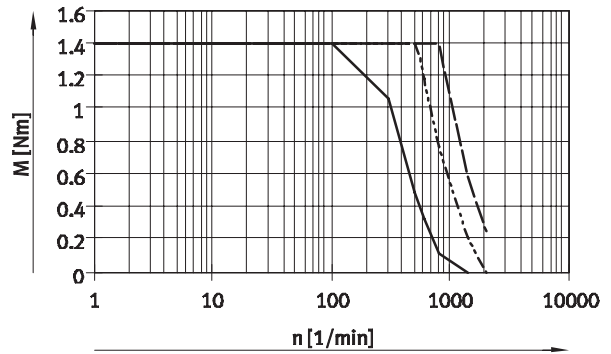

EMMS-ST-87-S

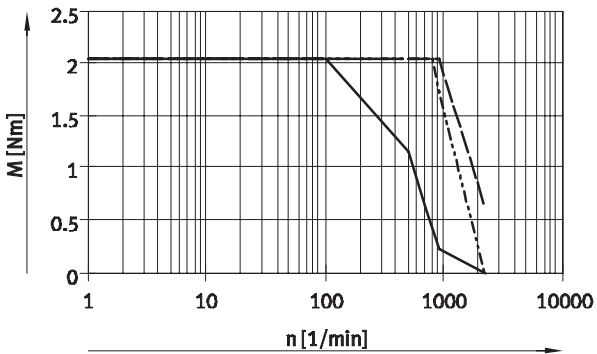

EMMS-ST-87-M

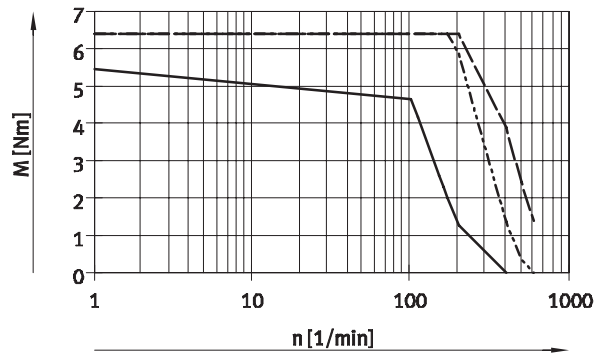

EMMS-ST-87-L

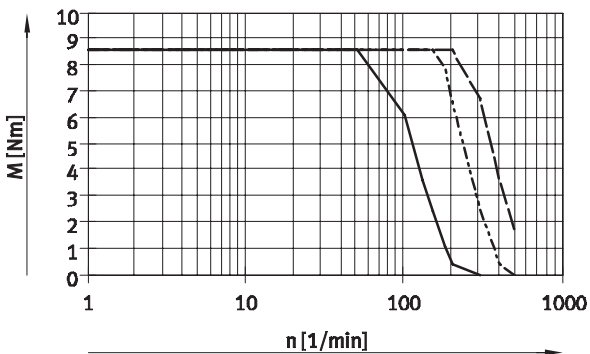

— 24VDC
 - - - 48VDC
 - · - 72VDC



Note

The characteristic curves apply in combination with the motor controller CMMS-ST. The size EMMS-ST-87 is operated with the motor controller CMMS-ST with max. 8 A.

Stepper motors EMMS-ST

Technical data

Dimensions

Download CAD data → www.festo.com

EMMS-ST...-S

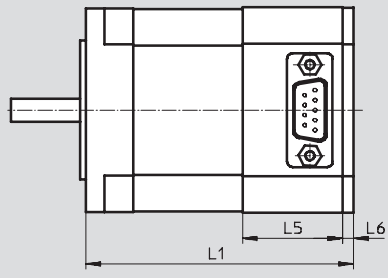

EMMS-ST...-SB

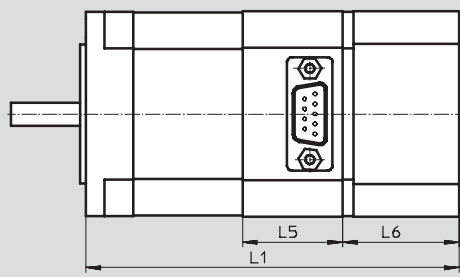

EMMS-ST...-SE/SEB

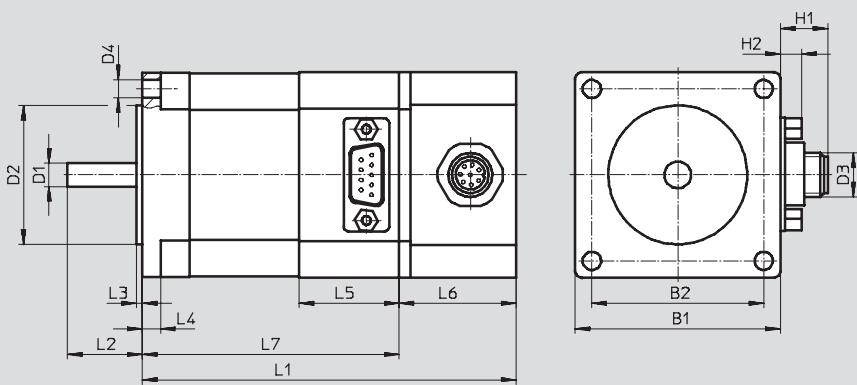

Plug assignment

9-pin Sub-D plug
with size 42, 57

15-pin Sub-D plug
with size 87

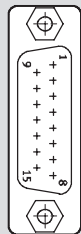
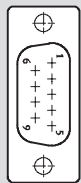

Stepper motors EMMS-ST

Technical data

FESTO

Type	B1	B2	D1 ∅	D2 ∅	D3	D4 ∅	H1	H2
EMMS-ST-42-S-S	42.3	31	5-0.012	22-0.05	-	M3x4.5	-	6.5
EMMS-ST-42-S-SE					M12		13	
EMMS-ST-42-S-SB					-		-	
EMMS-ST-42-S-SEB					M12		13	
EMMS-ST-57-S-S	56.4	47.14	6.35-0.013	38.1±0.025	-	5	-	
EMMS-ST-57-S-SE					M12		13	
EMMS-ST-57-S-SB					-		-	
EMMS-ST-57-S-SEB					M12		13	
EMMS-ST-57-M-S					-		-	
EMMS-ST-57-M-SE					M12		13	
EMMS-ST-57-M-SB					-		-	
EMMS-ST-57-M-SEB					M12		13	
EMMS-ST-87-S-S	85.6	69.5	11-0.013	73-0.046	-	6.6	-	
EMMS-ST-87-S-SE					M12		13	
EMMS-ST-87-S-SB					-		-	
EMMS-ST-87-S-SEB					M12		13	
EMMS-ST-87-M-S					-		-	
EMMS-ST-87-M-SE					M12		13	
EMMS-ST-87-M-SB					-		-	
EMMS-ST-87-M-SEB					M12		13	
EMMS-ST-87-L-S					-		-	
EMMS-ST-87-L-SE					M12		13	
EMMS-ST-87-L-SB					-		-	
EMMS-ST-87-L-SEB					M12		13	

Type	L1	L2	L3	L4	L5	L6	L7
EMMS-ST-42-S-S	66	24±1	2	-	24	2	-
EMMS-ST-42-S-SE	94					30	64±1
EMMS-ST-42-S-SB	114					50	
EMMS-ST-42-S-SEB	127					63	
EMMS-ST-57-S-S	73.5	20.6±0.5	1.6	5	27.5	3	-
EMMS-ST-57-S-SE	102.5					32	70.5±0.8
EMMS-ST-57-S-SB	123.5					53	
EMMS-ST-57-S-SEB	138					64.5	
EMMS-ST-57-M-S	95					3	-
EMMS-ST-57-M-SE	124					32	92±0.8
EMMS-ST-57-M-SB	145					53	
EMMS-ST-57-M-SEB	159.5					67.5	
EMMS-ST-87-S-S	82.6	27±1	2	8.38	31.4	3	-
EMMS-ST-87-S-SE	112.6					33	79.6±1
EMMS-ST-87-S-SB	132.6					53	
EMMS-ST-87-S-SEB	152.6					73	
EMMS-ST-87-M-S	114.9					3	-
EMMS-ST-87-M-SE	144.9					33	111.9±1
EMMS-ST-87-M-SB	164.9					53	
EMMS-ST-87-M-SEB	184.9					73	
EMMS-ST-87-L-S	144.9					3	-
EMMS-ST-87-L-SE	174.9					33	141.9±1
EMMS-ST-87-L-SB	194.9					53	
EMMS-ST-87-L-SEB	214.9					73	

Stepper motors EMMS-ST

Technical data

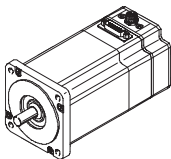
Ordering data						
	Size	Variant			Part No.	Type
		Basic version	With encoder	With brake		
	42	■			549 404	EMMS-ST-42-S-S
			■		549 405	EMMS-ST-42-S-SE
				■	549 406	EMMS-ST-42-S-SB
			■	■	549 407	EMMS-ST-42-S-SEB
	57	■			549 408	EMMS-ST-57-S-S
			■		549 409	EMMS-ST-57-S-SE
				■	549 410	EMMS-ST-57-S-SB
			■	■	549 411	EMMS-ST-57-S-SEB
		■			549 412	EMMS-ST-57-M-S
			■		549 413	EMMS-ST-57-M-SE
				■	549 414	EMMS-ST-57-M-SB
			■	■	549 415	EMMS-ST-57-M-SEB
	87	■			549 416	EMMS-ST-87-S-S
			■		549 417	EMMS-ST-87-S-SE
				■	549 418	EMMS-ST-87-S-SB
			■	■	549 419	EMMS-ST-87-S-SEB
		■			549 420	EMMS-ST-87-M-S
			■		549 421	EMMS-ST-87-M-SE
				■	549 422	EMMS-ST-87-M-SB
			■	■	549 423	EMMS-ST-87-M-SEB
		■			549 424	EMMS-ST-87-L-S
		■		549 425	EMMS-ST-87-L-SE	
		■	549 426	EMMS-ST-87-L-SB		
		■	549 427	EMMS-ST-87-L-SEB		

Stepper motors EMMS-ST

Accessories

FESTO

Gear unit EMGA

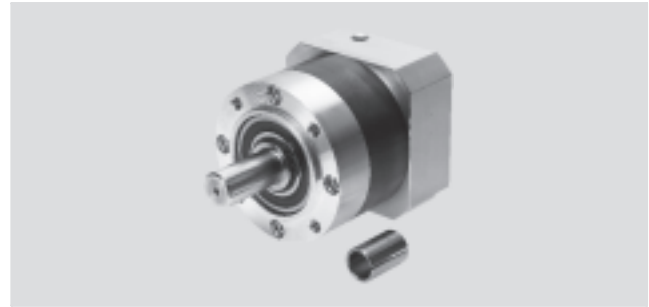

General technical data							
For motor size		42		57		87	
Gear unit type		EMGA-40-P-G...		EMGA-60-P-G...		EMGA-80-P-G...	
Gear unit ratio	[i]	3	5	3	5	3	5
Continuous output torque ¹⁾	[Nm]	11	14	22	22	85	110
Max. drive torque	[Nm]	17.6	22	22	22	136	176
Torsional resistance	[Nm/arcmin]	1		2.3		6	
Torsional backlash	[deg]	0.4		0.27		0.15	
Moment of inertia ²⁾	[kgcm ²]	0.031	0.19	0.135	0.078	0.77	0.45
Efficiency	[%]	96					
Operating temperature ³⁾	[°C]	-25 ... +90					
Protection class		IP54					

- 1) At the drive shaft
- 2) Referred to the drive shaft
- 3) Note the temperature range of the motor

Dimensions Download CAD data → www.festo.com

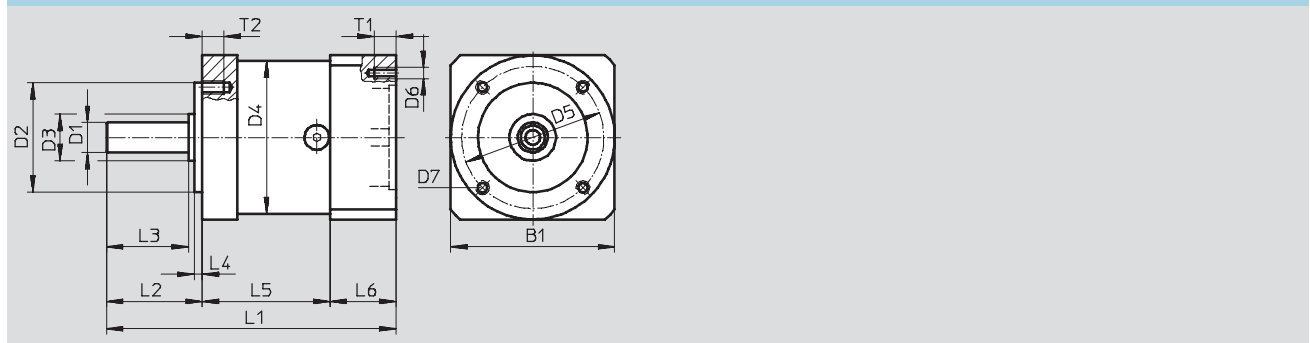

For size	B1	D1	D2	D3	D4	D5	D6	D7	L1	L2	L3	L4	L5	L6	T1	T2
		∅	∅	∅	∅	∅			±1.5		±0.2	±0.2				
42	40	10	26	12	40	34	∅3.4	M4	92.5	26±0.6	23	2	39	27.5	5	6
57	60	11	40	17	60	52	M4	M5	106	35±0.8	30	3	47	24	8	8
87	90	20	60	25	80	70	M5	M6	135.5	40±0.8	36	3	60	35.5	12	10

Ordering data			
For size	Gear unit ratio	Part No.	Type
42	3	549 428	EMGA-40-P-G3-SST-42
	5	549 429	EMGA-40-P-G5-SST-42
57	3	549 430	EMGA-60-P-G3-SST-57
	5	549 431	EMGA-60-P-G5-SST-57
87	3	549 432	EMGA-80-P-G3-SST-87
	5	549 433	EMGA-80-P-G5-SST-87

Stepper motors EMMS-ST

Accessories

Technical data – Cables			
Designation	Motor cable		Encoder cable
Type	NEBM-S1G9-...	NEBM-S1G15-...	NEBM-M12G8-...
For size	EMMS-ST-42/57	EMMS-ST-87	EMMS-ST-42/57/87
Min. bending radius [mm]	58	70	51
Ambient temperature [°]	-40 ... +70	-30 ... +70	-40 ... +70
Ambient temperature ¹⁾ [°]	-40 ... +70	-5 ... +70	-40 ... +70
Cable design	Screened		
Cable attribute	Suitable for drag chain		
Protection class	IP65		
Material	Polyurethane		

1) with flexible cable installation

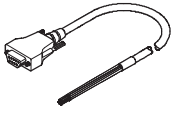
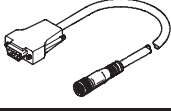
Ordering data			
	Cable length [m]	Part No.	Type
Motor cable			
	For EMMS-ST-42/57		
	5	550 740	NEBM-S1G9-E-5-LE6
	10	550 741	NEBM-S1G9-E-10-LE6
	15	550 742	NEBM-S1G9-E-15-LE6
	X length ¹⁾	550 743	NEBM-S1G9-E-...-LE6
	For EMMS-ST-87		
	5	550 744	NEBM-S1G15-E-5-LE6
	10	550 745	NEBM-S1G15-E-10-LE6
	15	550 746	NEBM-S1G15-E-15-LE6
	X length ¹⁾	550 747	NEBM-S1G15-E-...-LE6
Encoder cable			
	5	550 748	NEBM-M12G8-E-5-S1G9
	10	550 749	NEBM-M12G8-E-10-S1G9
	15	550 750	NEBM-M12G8-E-15-S1G9
	X length ¹⁾	550 751	NEBM-M12G8-E-...-S1G9

1) Max. 25 m

Motor controllers CMMS-ST, for stepper motors





Motor controllers CMMS-ST, for stepper motors

Key features

Comparison of motor controllers				
Motor controller		CMMS-ST	CMMS-AS	CMMP-AS
For motor type		Stepper motor	Servo motor	Servo motor
Torque at standstill	[Nm]	9.3	4.7	25
Peak torque	[Nm]	9.3	9.2	48
Speed	[rpm]	2,000	6,000	6,000
Position sets		63	63	255
Measuring system		Incremental	Incremental/absolute	Incremental/absolute
Extended I/O interface		4 working modes	4 working modes	Flexibly configurable
Notification of remaining distance		1 for n	1 for n	Separate for all positions
Torque reduction		No	No	Separate for all positions
Set linking		Linear	Linear	With branching
Safe stop		–	To EN 954-1 Cat3	To EN 954-1 Cat3

Performance characteristics

Compactness	Motion control
<ul style="list-style-type: none"> • Small dimensions • Full integration of all components for controller and power section, including RS232 and CANopen interface • Integrated brake chopper • Integrated EMC filters 	<ul style="list-style-type: none"> • Automatic actuation for a holding brake integrated in the motor • Adheres to the current CE and EN standards without additional external measures (motor cable length of up to 15 m) • Can be operated as a torque, speed or position controller • Integrated positioning controller • Time-optimised (trapezoidal) or jerk-free (S-shaped) positioning • Absolute and relative movements • Point-to-point positioning with and without approximate positioning

Fieldbus interfaces	Input/output	Integrated sequence control
Integrated: 	<ul style="list-style-type: none"> • Freely programmable I/Os • High-resolution 12-bit analogue input • Jog/teach mode • Simple linking to a higher-level controller via I/O or fieldbus • Synchronous operation • Master/slave mode 	<ul style="list-style-type: none"> • Automatic sequence of position sets without a higher-level controller • Linear and cyclic position sequences • Adjustable delay times
Optional: 		

Interpolating multi-axis movement	Servo mode
<ul style="list-style-type: none"> • With a suitable controller, the CMMS-ST can perform path movements with interpolation via CANopen. The controller specifies setpoint position values in a fixed time pattern to this end. In between, the servo positioning controller independently interpolates the data values between two data points. 	<ul style="list-style-type: none"> • “Servo Lite operation” (closed loop) thanks to encoder option, in other words no step losses, following errors are corrected

Travel program

- Linking of any number of position sets into a travel program
- Step criteria for the travel program possible via digital inputs, for example
 - MC – motion complete
 - I/O – digital inputs

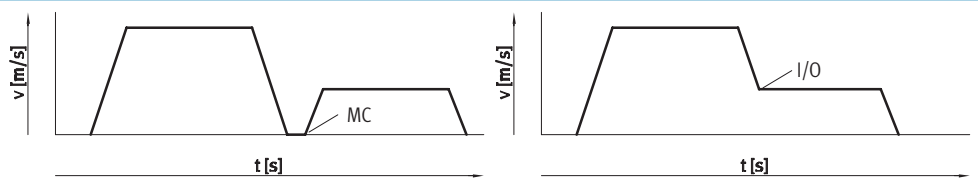

Motor controllers CMMS-ST, for stepper motors

Key features

FCT software – Festo Configuration Tool

Software platform for electric drives from Festo

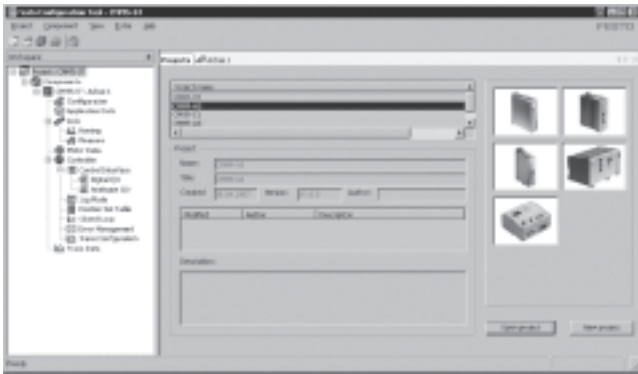

- All drives in a system can be managed and archived in a common project
- Project and data management for all supported device types
- Simple to use thanks to graphically-supported parameter entry
- Universal mode of operation for all drives
- Working offline at your desk or online at the machine

FHPP – Festo Handling and Positioning Profile

Optimised data profile

Festo has developed an optimised data profile, the “Festo Handling and Positioning Profile (FHPP)”, that is tailored to handling and positioning applications.

The FHPP data profile permits the actuation of Festo motor controllers, using a fieldbus interface, via standardised control and status bytes.

The following are defined, among others:

- Operating modes
- I/O data structure
- Parameter objects
- Sequence control

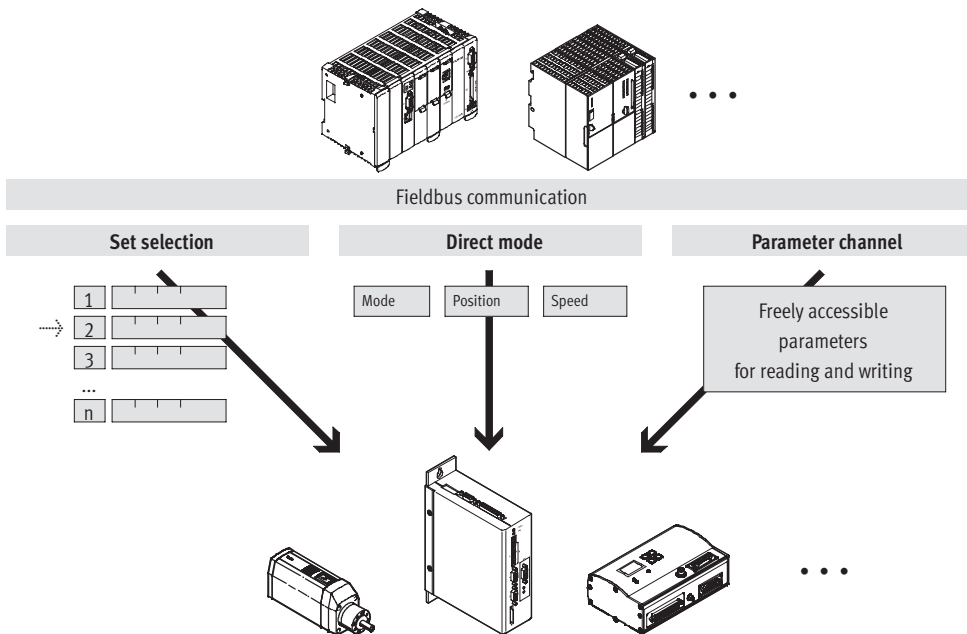

Motor controllers CMMS-ST, for stepper motors

Type codes

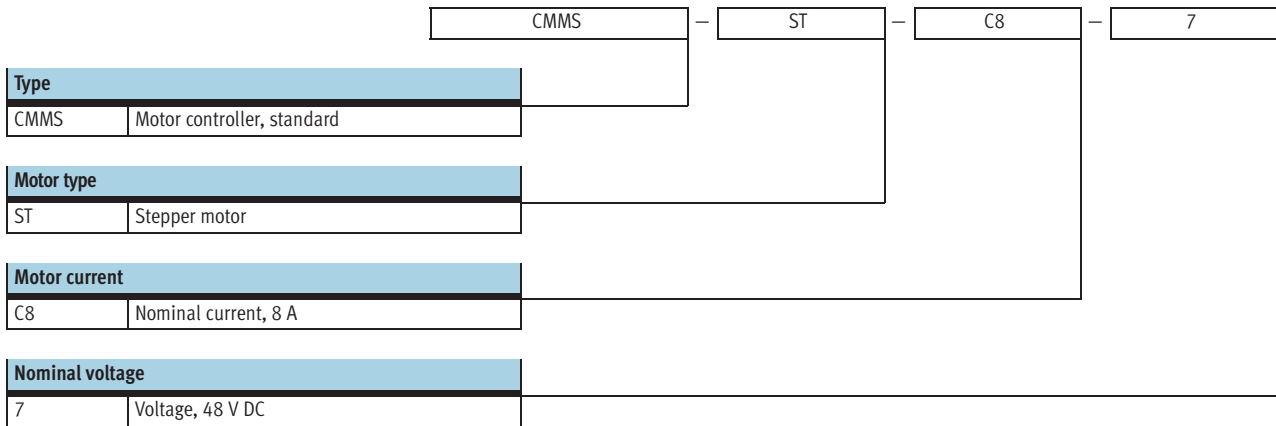

Motor controllers CMMS-ST, for stepper motors



Technical data

Fieldbus interfaces





General technical data		
Type of mounting		Screwed to a mounting plate
Operating mode		PWM MOSFET power amplifier
Motor actuation		Sinusoidal current impressing
Cycle rate	[kHz]	Constant 50
Rotary position generator		Encoder
Display		7-segment display
Parameterisation interface		RS232 (9,600 ... 115,000 bits/s)
Encoder interface input		As speed/position specification for the slave drive in synchronous mode
		RS422
Encoder interface output		Setpoint specification for downstream slave drive
Brake resistor, integrated	[Ω]	17
Pulse power of braking resistor	[kVA]	0.5
Impedance of setpoint input	[kΩ]	20
Operating range of analogue outputs	[V]	±10
Operating range of analogue inputs	[V]	±10
Number of analogue outputs		1
Number of analogue inputs		1
Characteristics of digital logic outputs		Freely configurable in some cases
Mains filter		Integrated
Product weight	[g]	2,000

Technical data – Fieldbus interface					
Interfaces		I/O	CANopen	Profibus DP	DeviceNet
Communication profile		–	DS301, FHPP	DP-V0 / FHPP	FHPP
		–	DS301, DSP402	Step7 functional modules	
Max. fieldbus transmission rate	[Mbit/s]	–	1	12	0.5
Interface	Integrated	■	■	–	–
	Optional	–	–	■ → 22	■ → 22

Electrical data		
General		
Nominal current setting		Via software
Max. peak current duration	[s]	2
Max. intermediate circuit voltage	[V DC]	75
Load supply		
Nominal voltage	[V DC]	24 ... 75
Nominal current	[A]	8
Peak current	[A]	12
Logic supply		
Nominal voltage	[V DC]	24 ±20%
Nominal current	[A]	0.3
Max. current of digital logic outputs	[mA]	100

Motor controllers CMMS-ST, for stepper motors

Technical data

Operating and environmental conditions		
Digital logic outputs		Not electrically separated
Logic inputs		Electrically separated
Protection class		IP20
Protective function		I ² t monitoring
		Current monitoring
		Voltage failure detection
		Following error monitoring
		Temperature monitoring
Ambient temperature	[°C]	0 ... +50
Storage temperature	[°C]	-25 ... +70
CE mark (see declaration of conformity)		To EU EMC Directive
Relative humidity	[%]	0 ... 90 (non-condensing)

View of motor controller

From the front

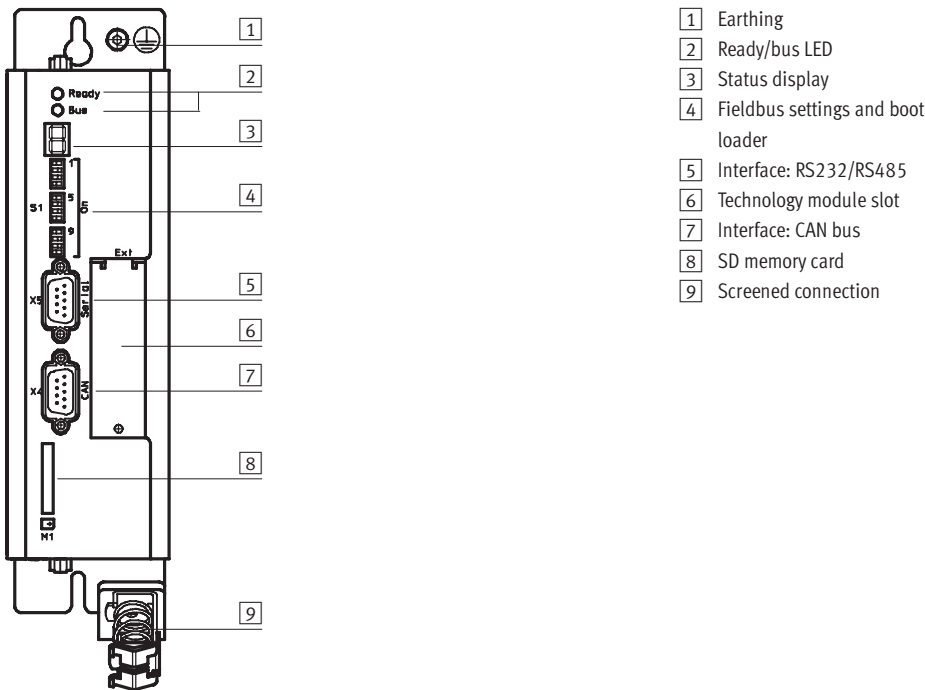

From above

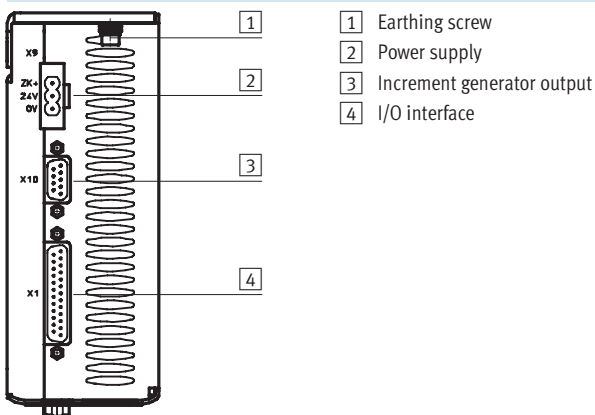

From underneath

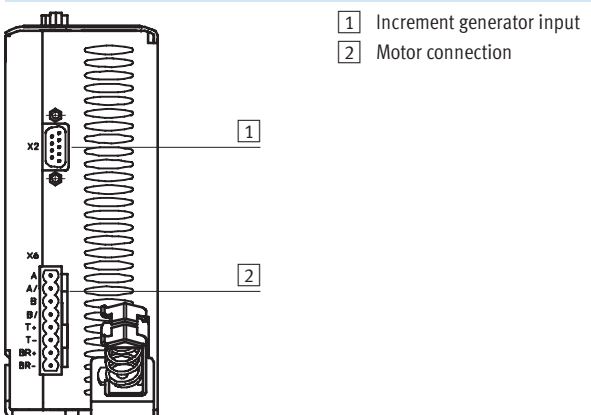

Motor controllers CMMS-ST, for stepper motors

Technical data

FESTO

Installation clearance for motor controller

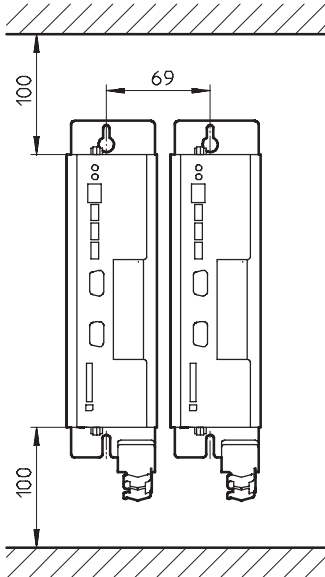

Dimensions

Download CAD data → www.festo.com

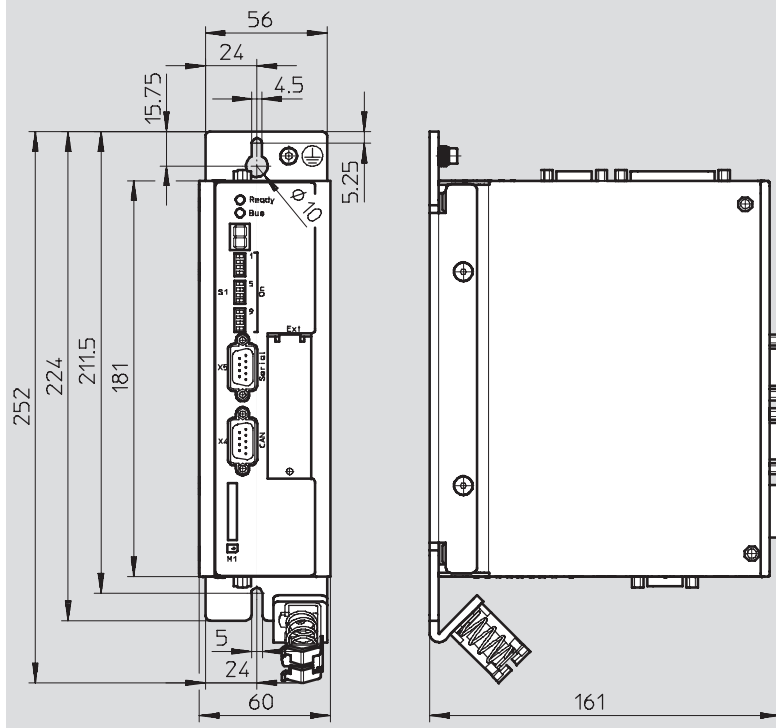



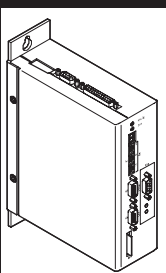

Ordering data

	Brief description	Part No.	Type
	The plug range NEKM (→ 22) and the operating package (→ 23) are included in the scope of delivery.	547 454	CMMS-ST-C8-7

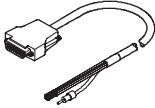
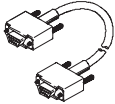
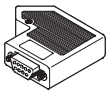
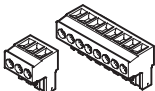
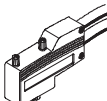
Motor controllers CMMS-ST, for stepper motors

Accessories

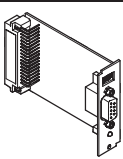
Ordering data – Cables and plugs					
	Brief description	Cable length [m]	Part No.	Type	
	Control cable, for I/O interface to any controller	2.5	552 254	NEBC-S1G25-K-2.5N-LE26	
	Programming cable	1.5	160 786	PS1-ZK11-NULLMODEM-1,5M	
	Encoder plug	–	552 274	NECC-S-S1G9-C2M	
	Plug range, comprising plug for power supply and plug for motor connection. The plug range is included in the scope of delivery	–	547 452	NEKM-C-1	
	Plug for Profibus interface	–	533 780	FBS-SUB-9-WS-PB-K	
	Plug for DeviceNet interface	–	525 635	FBSD-KL-2X5POL	

Ordering data – Plug-in cards					
	Brief description	Part No.	Type		
	Interface, for Profibus interface	547 450	CAMC-PB		
	Interface, for DeviceNet interface	547 451	CAMC-DN		
	Memory card, for data backup and firmware downloads	560 626	CAMC-M-S-F1-V1		

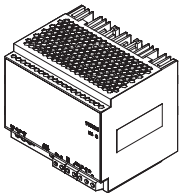
Ordering data – Power supply units						
	Brief description	Input voltage range [V AC]	Nominal output voltage [V DC]	Nominal output current [A]	Part No.	Type
	Power supply for motor controller	100 ... 240	24	5	547 867	SVG-1/230VAC-24VDC-5A
				10	547 868	SVG-1/230VAC-24VDC-10A
			48	5	542 403	SVG-1/230VAC-48VDC-5A
		10		542 404	SVG-1/230VAC-48VDC-10A	
		20	542 405	SVG-3/400VAC-48VDC-20A		

 **Note**

If a common power supply unit is used to supply the power section and the control section, the voltage tolerances for the supply to the control section cannot be maintained at high braking power. This can result in damage to the control section.

Always use separate power supply units to supply the power section and the control section.

Motor controllers CMMS-ST, for stepper motors

Accessories

Ordering data – Software and documentation		
	Brief description	Part No. Type
	Operating package contains: – CD-ROM – with user documentation for CMMS-ST, in de, en, es, fr, it, sv – with FCT (Festo Configuration Tool) configuration software, in de, en – Brief description This package is included in the scope of delivery	558 330 PBP-CMMS-ST

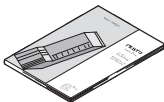
Ordering data – Documentation ¹⁾				
	Language	Part No. Type	Part No. Type	
		for motor controller		Festo Handling and Positioning Profile (FHPP) for the motor controller family CMM...
	DE	554 339 P.BE-CMMS-ST-HW-DE	555 695 P.BE-CMM-FHPP-SW-DE	
	EN	554 340 P.BE-CMMS-ST-HW-EN	555 696 P.BE-CMM-FHPP-SW-EN	
	ES	554 341 P.BE-CMMS-ST-HW-ES	555 697 P.BE-CMM-FHPP-SW-ES	
	FR	554 342 P.BE-CMMS-ST-HW-FR	555 698 P.BE-CMM-FHPP-SW-FR	
	IT	554 343 P.BE-CMMS-ST-HW-IT	555 699 P.BE-CMM-FHPP-SW-IT	
	SV	554 344 P.BE-CMMS-ST-HW-SV	555 700 P.BE-CMM-FHPP-SW-SV	
		for CANopen interface		for Profibus interface
	DE	554 351 P.BE-CMMS-CO-SW-DE	554 345 P.BE-CMMS-FHPP-PB-SW-DE	
	EN	554 352 P.BE-CMMS-CO-SW-EN	554 346 P.BE-CMMS-FHPP-PB-SW-EN	
	ES	554 353 P.BE-CMMS-CO-SW-ES	554 347 P.BE-CMMS-FHPP-PB-SW-ES	
	FR	554 354 P.BE-CMMS-CO-SW-FR	554 348 P.BE-CMMS-FHPP-PB-SW-FR	
	IT	554 355 P.BE-CMMS-CO-SW-IT	554 349 P.BE-CMMS-FHPP-PB-SW-IT	
	SV	554 356 P.BE-CMMS-CO-SW-SV	554 350 P.BE-CMMS-FHPP-PB-SW-SV	
		for DeviceNet interface		
	DE	554 357 P.BE-CMMS-FHPP-DN-SW-DE		
	EN	554 358 P.BE-CMMS-FHPP-DN-SW-EN		
	ES	554 359 P.BE-CMMS-FHPP-DN-SW-ES		
	FR	554 360 P.BE-CMMS-FHPP-DN-SW-FR		
	IT	554 361 P.BE-CMMS-FHPP-DN-SW-IT		
	SV	554 362 P.BE-CMMS-FHPP-DN-SW-SV		

1) User documentation in paper form is not included in the scope of delivery



Servo motors EMMS-AS

Key features

Everything from a single source

Motors EMMS-AS

→ 28



- Permanently excited, electro-dynamic, brushless servo motor
- Choice of two encoder types:
 - Digital single-turn absolute displacement encoder (standard)
 - Digital multi-turn absolute displacement encoder (optional)
- Optionally with holding brake
- Protection class:
 - IP54 (motor shaft)
 - IP65 (motor housing with connection technology)
- Optimised connection technology:
 - With size 40, 55: Terminal connection
 - With size 70, 100, 140: Round plug: M23 power connection, rotatable M12 encoder connection

Gear unit EMGA-SAS

→ 36



- Planetary gear unit
- Gear unit ratio $i = 3$ and 5 , available ex-stock
- Further designs and gear ratios on request
- Life time lubrication
- Protection class: IP54

Motor controller CMMP-AS

→ 53



- Digital servo controller in 4 performance classes (0.5 kVA ... 6 kVA)
- Actuation of AC servo and linear motors
- Integrated EMC filters
- Integrated brake chopper
- Integrated safety functions
- Position controller with closed-loop position control (256 position sets)
- Speed controller
- Torque control via current controller
- Range of control functions
- Interfaces:
 - I/O interface
 - CANopen, standard
 - Profibus DP, optional module
 - DeviceNet, optional module
 - Sercos 2, optional module

Motor and encoder cables NEBM

→ 38

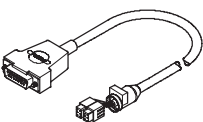

- Can be used in a wide temperature range
- Suitable for chain link trunking
- Protection class IP65

Axial and parallel kits EAMM

→ Internet: eamm



- Specified kits for all electro-mechanical axes from Festo
- Each kit includes the relevant necessary coupling housing, couplings and motor flange as well as all screws

Servo motors EMMS-AS

Type codes

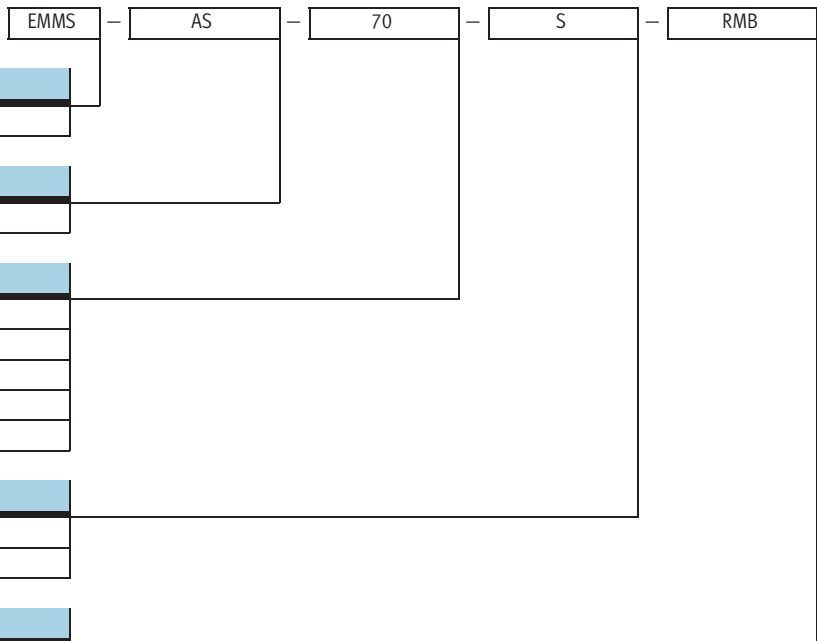

Type

EMMS	Motor
------	-------

Motor type

AS	Servo motor
----	-------------

Flange dimensions

40	40 mm
55	55 mm
70	70 mm
100	100 mm
140	140 mm

Overall length options

S	Small
M	Medium

Additional function

T	Terminal connection
R	Round plug
S	Single turn
M	Multi-turn
B	Brake

Servo motors EMMS-AS

Technical data

FESTO



General technical data			
Size		40	55
Motor			
Nominal voltage	[V DC]	360	360
Nominal current	[A]	0.6	1.2
Peak current	[A]	3.3	5
Rated output	[W]	222	467
Nominal torque	[Nm]	0.2	0.68
Peak torque	[Nm]	1	2.7
Torque at standstill	[Nm]	0.26	0.98
Nominal speed	[1/min]	10,300	6,600
Max. speed	[1/min]	11,180	7,330
Motor constant	[Nm/A]	0.344	0.558
Winding resistance	[Ω]	34.833	14.35
Winding inductance	[mH]	10.36	13.83
Drive mass moment of inertia	[kgcm ²]	0.054	0.223
Drive mass moment of inertia with brake	[kgcm ²]	0.064	0.245
Radial load on shaft	[N]	82	150
Axial load on shaft	[N]	12	75
Brake			
Operating voltage	[V DC]	24 +6 ... -10%	24 +6 ... -10%
Output	[W]	6.2	10
Holding torque	[Nm]	0.4	0.8
Mass moment of inertia	[kgcm ²]	0.01	0.022

Size		70-S	70-M
Motor			
Nominal voltage	[V DC]	360	360
Nominal current	[A]	2.2	2.6
Peak current	[A]	5	10
Rated output	[W]	866	1 061
Nominal torque	[Nm]	1.43	2.29
Peak torque	[Nm]	3.1	7.75
Torque at standstill	[Nm]	1.64	2.56
Nominal speed	[1/min]	5,300	4,100
Max. speed	[1/min]	6,300	4,780
Motor constant	[Nm/A]	0.647	0.864
Winding resistance	[Ω]	7.66	6.71
Winding inductance	[mH]	0.015	0.013
Drive mass moment of inertia	[kgcm ²]	0.379	0.611
Drive mass moment of inertia with brake	[kgcm ²]	0.449	0.68
Radial load on shaft	[N]	150	200
Axial load on shaft	[N]	75	75
Brake			
Operating voltage	[V DC]	24 +6 ... -10%	24 +6 ... -10%
Output	[W]	11	11
Holding torque	[Nm]	2	2
Mass moment of inertia	[kgcm ²]	0.071	0.073

Servo motors EMMS-AS

Technical data

FESTO

General technical data				
Size		100-S		100-M
Motor				
Nominal voltage	[V DC]	360	565	565
Nominal current	[A]	3.8	3.3	3.4
Peak current	[A]	10	15	15
Rated output	[W]	1,497	1,573	2,015
Nominal torque	[Nm]	3.76	3.24	5.69
Peak torque	[Nm]	9.2	12.5	22.1
Torque at standstill	[Nm]	4.71		8.09
Nominal speed	[1/min]	3,500	4,600	3,400
Max. speed	[1/min]	4,130	5,950	3,750
Motor constant	[Nm/A]	0.984		1.652
Winding resistance	[Ω]	2.92		3.18
Winding inductance	[mH]	0.009		0.111
Drive mass moment of inertia	[kgcm ²]	2.529		4.729
Drive mass moment of inertia with brake	[kgcm ²]	3.085		5.285
Radial load on shaft	[N]	300		570
Axial load on shaft	[N]	150		150
Brake				
Operating voltage	[V DC]	24 +6 ... -10%		24 +6 ... -10%
Output	[W]	18		18
Holding torque	[Nm]	9		9
Mass moment of inertia	[kgcm ²]	0.555		0.555

Size		140-S		140-M
Motor				
Nominal voltage	[V DC]	565		565
Nominal current	[A]	4.4		7.4
Peak current	[A]	15		20
Rated output	[W]	2,663		4,827
Nominal torque	[Nm]	9.55		20.05
Peak torque	[Nm]	25.6		48.8
Torque at standstill	[Nm]	11.32		25.48
Nominal speed	[1/min]	2,600		2,000
Max. speed	[1/min]	2,930		2,210
Motor constant	[Nm/A]	2.166		2.72
Winding resistance	[Ω]	3.31		1.442
Winding inductance	[mH]	0.02		0.013
Drive mass moment of inertia	[kgcm ²]	8.189		19.027
Drive mass moment of inertia with brake	[kgcm ²]	9.271		20.108
Radial load on shaft	[N]	780		1,060
Axial load on shaft	[N]	200		200
Brake				
Operating voltage	[V DC]	24 +6 ... -10%		24 +6 ... -10%
Output	[W]	15.6		15.6
Holding torque	[Nm]	18		18
Mass moment of inertia	[kgcm ²]	1.082		1.082

Servo motors EMMS-AS

Technical data



Technical data – Encoder		
Type	EMMS-AS-...-...S... Absolute, single turn	EMMS-AS-...-...M... Absolute, multi-turn
Digital encoder, inductive		
Operating voltage [V DC]	5	
Protocol	EnDat 2.2	
Version	Standard	Optional
Resolution	65,536 position values within one revolution (360°), 16 bit	
	–	– 4,096 revolutions, 12 bit – Battery-free system

Weight [g]								
Size	40	55	70-S	70-M	100-S	100-M	140-S	140-M
Product weight	1,000	1,600	2,100	2,700	4,800	6,900	9,600	16,200
With brake	1,050	1,700	2,300	2,900	5,300	7,500	10,400	17,000

Operating and environmental conditions	
Protection class: motor shaft	IP54
Protection class: motor housing with connection technology	IP65
Ambient temperature [°C]	–10 ... +40 (up to 130 °C with derating)
Storage temperature [°C]	–20 ... +60
Insulation protection class	F
Rated class to EN 60034-1	S1
Heat class to EN 60034-1	F
CE symbol (see declaration of conformity)	In accordance with EU EMC directive
Certification	C-UL-US recognised (OL)
Relative air humidity (non-condensing) [%]	0 ... 90
Corrosion resistance class CRC ¹⁾	2

- 1) Corrosion resistance class 2 to Festo standard 940 070
Components subject to moderate corrosion stress. Externally visible parts with primarily decorative surface requirements which are in direct contact with a normal industrial environment or media such as coolants or lubricating agents.

Servo motors EMMS-AS

Technical data

Pin allocation

Sizes 40, 55

Motor, output

Encoder

Encoder

Temperature sensor (PTC) and holding brake

Black plug

Red plug

Yellow plug

Blue plug

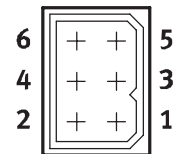
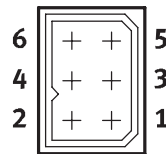
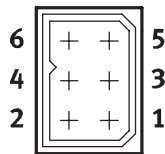
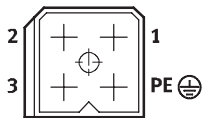

PIN	Function
1	Phase V
2	Phase W
3	Phase U
PE	PE (protective earth)

PIN	Function
1	DATA
2	DATA/
3	0 V
4	UP
5	CLOCK
6	CLOCK/

PIN	Function
1	-SENS
2	+SENS
3	-
4	-
5	-
6	-

PIN	Function
1	Temperature sensor M _T +
2	Temperature sensor M _T -
3	Holding brake BR+
4	Holding brake BR-
5	-
6	-

Sizes 70, 100, 140

Motor

Encoder

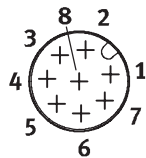
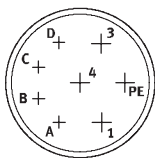

PIN	Function
1	Phase U
PE	PE (protective earth)
3	Phase W
4	Phase V
A	Temperature sensor M _T +
B	Temperature sensor M _T -
C	Holding brake BR+
D	Holding brake BR-

PIN	Function
1	-SENS
2	+SENS
3	DATA
4	DATA/
5	0 V
6	CLOCK/
7	CLOCK
8	UP

Servo motors EMMS-AS

Technical data

Torque M as a function of rotational speed n

EMMS-AS-40-M (intermediate circuit voltage = 360 V)

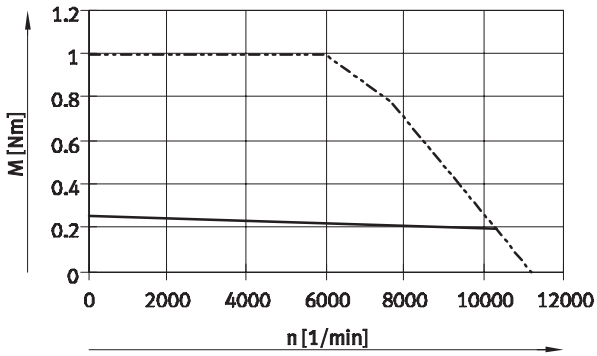

EMMS-AS-55-S (intermediate circuit voltage = 360 V)

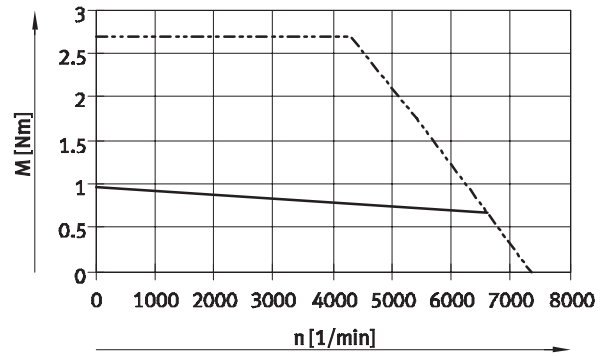

EMMS-AS-70-S (intermediate circuit voltage = 360 V)

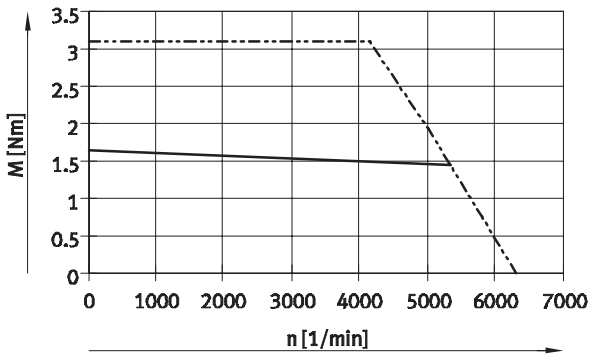

EMMS-AS-70-M (intermediate circuit voltage = 360 V)

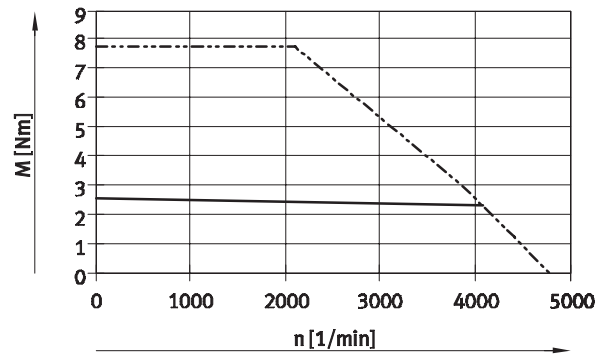

EMMS-AS-100-S (intermediate circuit voltage = 360 V)

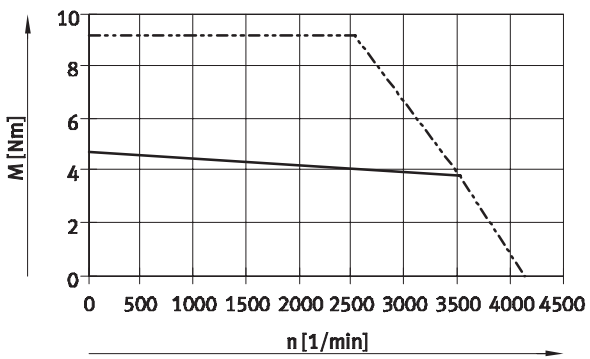

EMMS-AS-100-S (intermediate circuit voltage = 565 V)

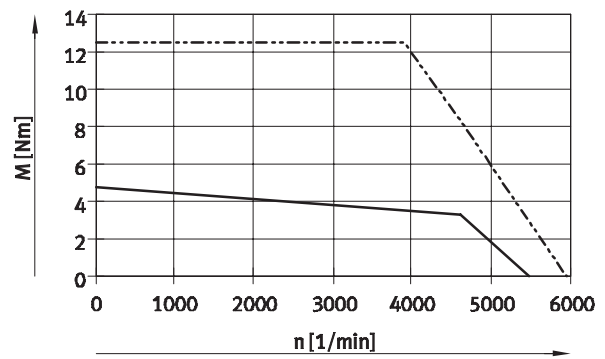

— Rated torque
 - - - Peak torque

Servo motors EMMS-AS

Technical data

Torque M as a function of rotational speed n

EMMS-AS-100-M (intermediate circuit voltage = 565 V)

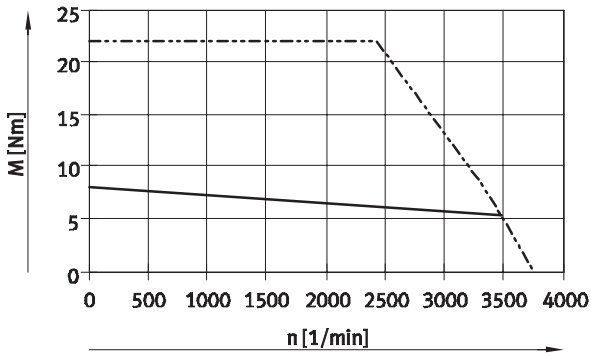

EMMS-AS-140-S (intermediate circuit voltage = 565 V)

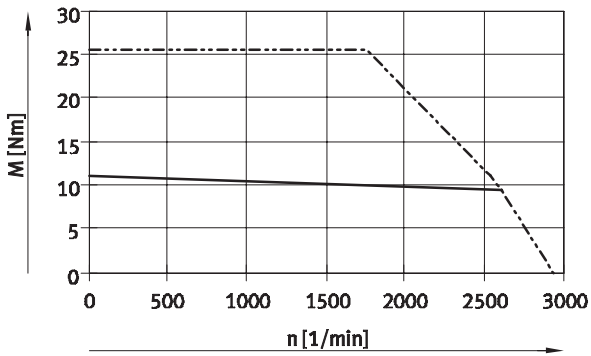

EMMS-AS-140-M (intermediate circuit voltage = 565 V)

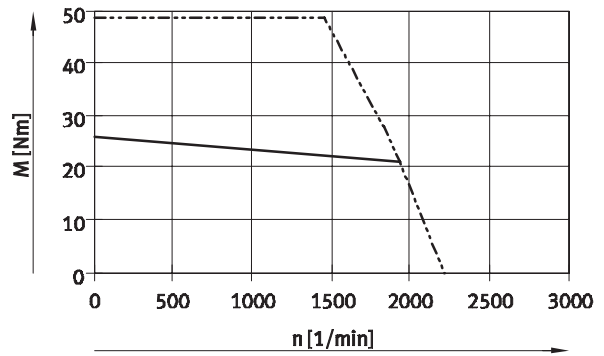

— Rated torque
 - - - Peak torque

Servo motors EMMS-AS

Technical data

Dimensions

Download CAD data → www.festo.com

Size 40

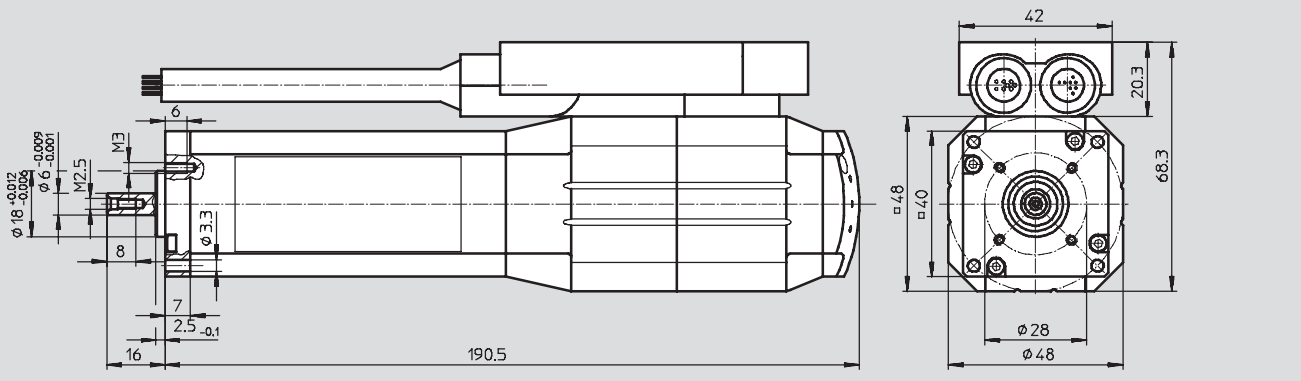

Size 55

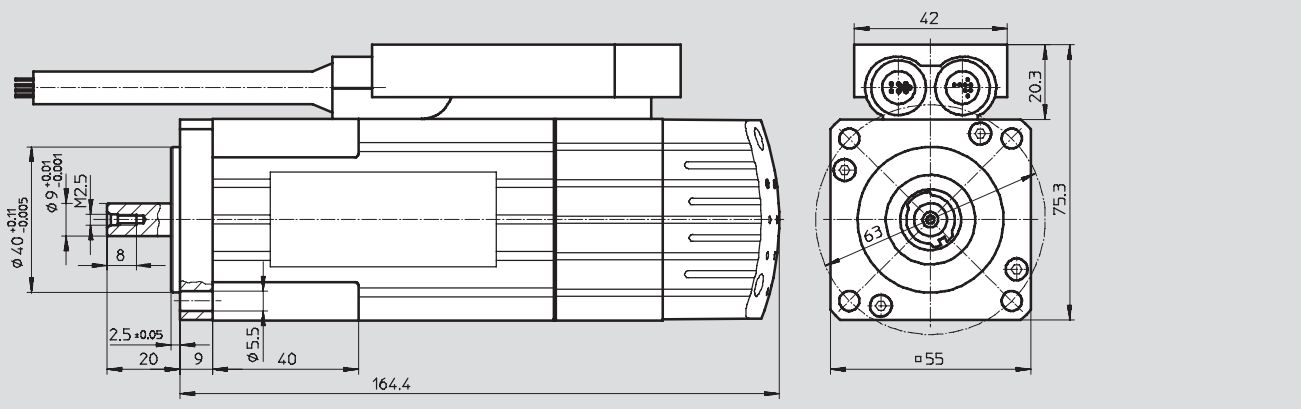

Sizes 70, 100, 140

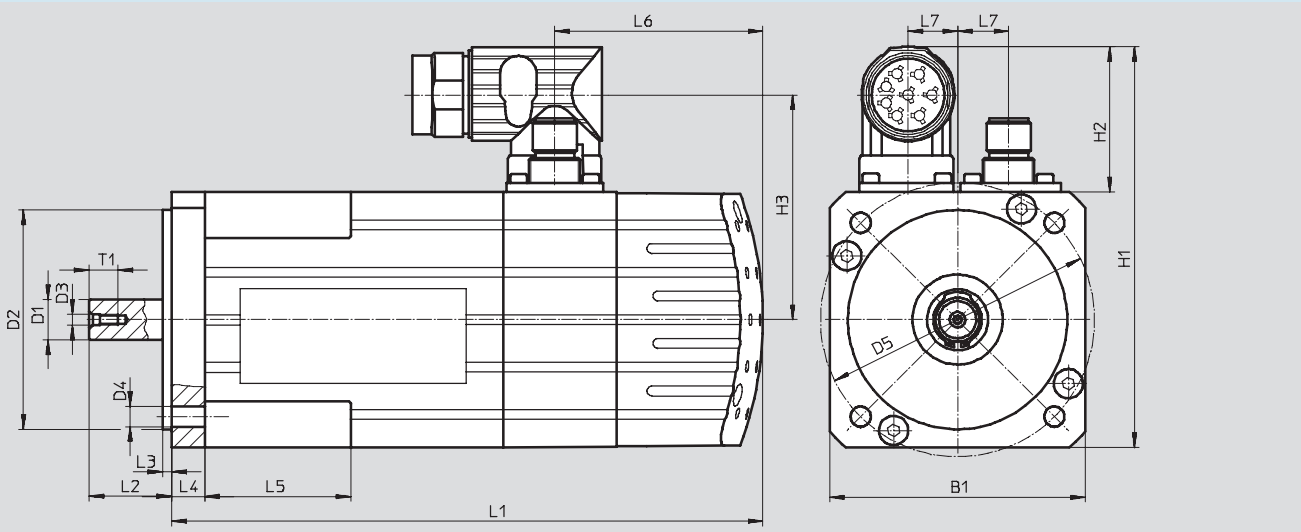

Servo motors EMMS-AS

Technical data

FESTO

Size	Type	B1	D1 ∅	D2 ∅	D3	D4 ∅	D5 ∅	H1	H2
70	EMMS-AS-70-S	70	11	60	M2.5	5.5	75	109.5	39.5
	EMMS-AS-70-M		+0.012/+0.001	+0.012/+0.007					
100	EMMS-AS-100-S	100.5	19	95	M4	9.2	115	140	
	EMMS-AS-100-M		+0.015/+0.002	+0.013/-0.009					
140	EMMS-AS-140-S	140.5	24	130	M4	11.3	165	180	
	EMMS-AS-140-M		+0.015/+0.002	+0.018/-0.007					

Size	Type	H3	L1	L2	L3	L4	L5	L6	L7	T1
70	EMMS-AS-70-S	61.5	161.8	22.7	2.5 _{-0.1}	9	40	57	14	8
	EMMS-AS-70-M		187.3							
100	EMMS-AS-100-S	77	192.3	40	3	9.8	-	58.9	19	16
	EMMS-AS-100-M		243.3							
140	EMMS-AS-140-S	97.7	209	50	3.5	12.2	-	58.6	33.5	16
	EMMS-AS-140-M		285.5							

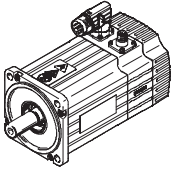
Ordering data		Variant					Part No.	Type	
Size	Variant	Single turn	Multi-turn	With brake	Small	Medium			
	40	■				■	550 106	EMMS-AS-40-M-TS	
			■				■	550 107	EMMS-AS-40-M-TM
		■		■			■	550 108	EMMS-AS-40-M-TSB
			■	■			■	550 109	EMMS-AS-40-M-TMB
	55	■				■		550 110	EMMS-AS-55-S-TS
			■			■		550 111	EMMS-AS-55-S-TM
		■		■	■	■		550 112	EMMS-AS-55-S-TSB
			■	■	■	■		550 113	EMMS-AS-55-S-TMB
		■				■		550 114	EMMS-AS-70-S-RS
	70		■			■		550 115	EMMS-AS-70-S-RM
		■		■	■	■		550 116	EMMS-AS-70-S-RSB
			■	■	■	■		550 117	EMMS-AS-70-S-RMB
		■					■	550 118	EMMS-AS-70-M-RS
			■				■	550 119	EMMS-AS-70-M-RM
				■	■	■	■	550 120	EMMS-AS-70-M-RSB
				■	■	■	■	550 121	EMMS-AS-70-M-RMB
		100	■				■		550 122
			■			■		550 123	EMMS-AS-100-S-RM
■			■	■	■		550 124	EMMS-AS-100-S-RSB	
	■		■	■	■		550 125	EMMS-AS-100-S-RMB	
■						■	550 127	EMMS-AS-100-M-RS	
	■					■	550 128	EMMS-AS-100-M-RM	
			■	■	■	■	550 129	EMMS-AS-100-M-RSB	
			■	■	■	■	550 130	EMMS-AS-100-M-RMB	
140	■				■		550 131	EMMS-AS-140-S-RS	
		■			■		550 132	EMMS-AS-140-S-RM	
	■		■	■	■		550 133	EMMS-AS-140-S-RSB	
		■	■	■	■		550 134	EMMS-AS-140-S-RMB	
	■					■	550 135	EMMS-AS-140-M-RS	
		■				■	550 136	EMMS-AS-140-M-RM	
	■		■	■	■	■	550 137	EMMS-AS-140-M-RSB	
			■	■	■	■	550 138	EMMS-AS-140-M-RMB	

Servo motors EMMS-AS

Accessories



Gear unit EMGA

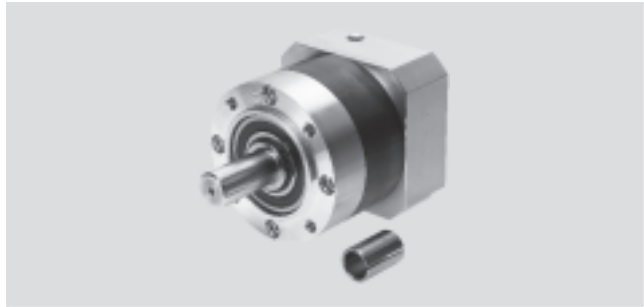

General technical data									
For motor size		40		55		70			
Gear unit type		EMGA-40-P-G...-40		EMGA-60-P-G...-55		EMGA-60-P-G...-70		EMGA-80-P-G...-70	
Gear unit ratio		3:1	5:1	3:1	5:1	3:1	5:1	3:1	5:1
Continuous driving torque ¹⁾	[Nm]	11	14	22	22	22	22	85	110
Max. driving torque ²⁾	[Nm]	17.6	22	22	22	22	22	136	176
Torsional resistance	[Nm/arcmin]	1		2.3		2.3		6	
Torsional backlash	[deg]	0.4		0.27		0.27		0.15	
Moment of inertia ³⁾	[kgcm ²]	0.031	0.19	0.135	0.078	0.135	0.078	0.77	0.45
Efficiency	[%]	96							
Operating temperature ⁴⁾	[°C]	-25 ... +90							
Protection class		IP54							

For motor size		100		100		140			
Gear unit type		EMGA-80-P-G...-100		EMGA-120-P-G...-100		EMGA-120-P-G...-140		EMGA-160-P-G...-140	
Gear unit ratio		3:1	5:1	3:1	5:1	3:1	5:1	3:1	5:1
Continuous driving torque ¹⁾	[Nm]	85	110	115	195	115	195	400	450
Max. driving torque ²⁾	[Nm]	136	176	184	213	184	213	640	720
Torsional resistance	[Nm/arcmin]	6		12		12		38	
Torsional backlash	[deg]	0.15		0.13		0.13		0.1	
Moment of inertia ³⁾	[kgcm ²]	0.77	0.45	2.63	1.53	2.63	1.53	12.14	6.07
Efficiency	[%]	96							
Operating temperature ⁴⁾	[°C]	-25 ... +90							
Protection class		IP54							

- 1) At the drive shaft
- 2) The specifications refer to a drive shaft speed of 100 rpm as well as operating mode S1 and a temperature of 30 °C
- 3) In relation to the drive shaft
- 4) Note the temperature range of the motor

Servo motors EMMS-AS

Accessories

FESTO

Dimensions

Download CAD data → www.festo.com

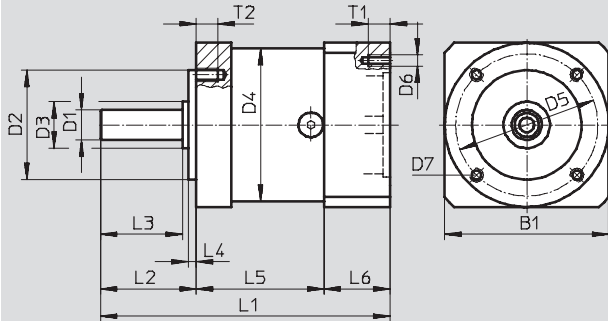

Type	B1	D1 ∅ h7	D2 ∅ h7	D3 ∅	D4 ∅	D5 ∅	D6	D7
EMGA-40-P-G...-40	40	10	26	12	40	34	M3	M4
EMGA-60-P-G...-55	60	11	40	17	60	52	M5	M5
EMGA-60-P-G...-70	70	11	40	17	60	52	M5	M5
EMGA-80-P-G...-70	80	20	60	25	80	70	M5	M6
EMGA-80-P-G...-100	100	20	60	25	80	70	M8	M6
EMGA-120-P-G...-100	115	25	80	35	115	100	M8	M10
EMGA-120-P-G...-140	140	25	80	35	115	100	M10	M10
EMGA-160-P-G...-140	140	40	130	55	160	145	M10	M12

Type	L1	L2	L3 ±0.2	L4 ±0.2	L5	L6	T1	T2
EMGA-40-P-G...-40	88.5±1.5	26±0.6	12	2	39	23.5	6	6
EMGA-60-P-G...-55	106±1.5	35±0.8	30	3	47	24	12	8
EMGA-60-P-G...-70	106±1.5	35±0.8	30	3	47	24	12	8
EMGA-80-P-G...-70	133.5±1.5	40±0.8	36	3	60	33.5	12	10
EMGA-80-P-G...-100	143.5±1.5	40±0.8	36	3	60	43.5	16	10
EMGA-120-P-G...-100	176.5±2	55±0.8	50	4	74	47.5	20	16
EMGA-120-P-G...-140	186±2	55±0.8	50	4	74	57.5	25	16
EMGA-160-P-G...-140	255.5±2	87±0.8	80	5	104	64.5	25	20

Ordering data

For size	Gear unit ratio	Part No.	Type
40	3	552 186	EMGA-40-P-G3-SAS-40
	5	552 187	EMGA-40-P-G5-SAS-40
55	3	552 188	EMGA-60-P-G3-SAS-55
	5	552 189	EMGA-60-P-G5-SAS-55
70	3	552 190	EMGA-60-P-G3-SAS-70
	5	552 191	EMGA-60-P-G5-SAS-70
	3	552 192	EMGA-80-P-G3-SAS-70
	5	552 193	EMGA-80-P-G5-SAS-70
100	3	552 194	EMGA-80-P-G3-SAS-100
	5	552 195	EMGA-80-P-G5-SAS-100
	3	552 196	EMGA-120-P-G3-SAS-100
	5	552 197	EMGA-120-P-G5-SAS-100
140	3	552 198	EMGA-120-P-G3-SAS-140
	5	552 199	EMGA-120-P-G5-SAS-140
	3	552 200	EMGA-160-P-G3-SAS-140
	5	552 201	EMGA-160-P-G5-SAS-140

Servo motors EMMS-AS

Accessories

Technical data – Cables								
Designation	Motor cable				Encoder cable			
For size	EMMS-AS-40/55		EMMS-AS-70/100/140		EMMS-AS-40/55		EMMS-AS-70/100/140	
Type	NEBM-T1G7-...		NEBM-M23G6-...		NEBM-T1G8-...		NEBM-M12W8-...	
Plug colour/PIN	Black	Blue	1 ... 4	A ... D	Yellow	Red	1 ... 8	
Voltage [V]	630	48	630	300	30	30	30	
Current [A]	12	3	16	8	3	2	2	
Surge voltage [kV]	4	0.5	4	2.5	0.5	0.5	0.8	
Degree of contamination	3							
Min. bending radius [mm]	55		64		75		75	
Ambient temperature [°]	-40 ... +70		-40 ... +90		-40 ... +80		-40 ... +80	
Ambient temperature ¹⁾ [°]	-50 ... +90		-50 ... +90		-10 ... +80		-10 ... +80	
Cable design	EMC optimised							
Cable attribute	Suitable for chain link trunking							
Protection class	IP65		IP67		IP65		IP65	
Material	Polyurethane							

1) With flexible cable installation

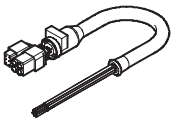
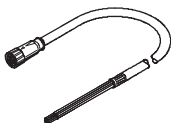
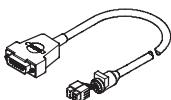
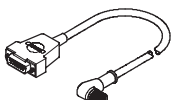
Ordering data			
	Cable length [m]	Part No.	Type
Motor cable			
	For EMMS-AS-40/55		
	5	550 306	NEBM-T1G7-E-5-N-LE7
	10	550 307	NEBM-T1G7-E-10-N-LE7
	15	550 308	NEBM-T1G7-E-15-N-LE7
	X length ¹⁾	550 309	NEBM-T1G7-E- -N-LE7
	For EMMS-AS-70/100/140		
	5	550 310	NEBM-M23G6-E-5-N-LE7
	10	550 311	NEBM-M23G6-E-10-N-LE7
	15	550 312	NEBM-M23G6-E-15-N-LE7
	X length ¹⁾	550 313	NEBM-M23G6-E- -N-LE7
Encoder cable			
	For EMMS-AS-40/55		
	5	550 314	NEBM-T1G8-E-5-N-S1G15
	10	550 315	NEBM-T1G8-E-10-N-S1G15
	15	550 316	NEBM-T1G8-E-15-N-S1G15
	X length ¹⁾	550 317	NEBM-T1G8-E- -N-S1G15
	For EMMS-AS-70/100/140		
	5	550 318	NEBM-M12W8-E-5-N-S1G15
	10	550 319	NEBM-M12W8-E-10-N-S1G15
	15	550 320	NEBM-M12W8-E-15-N-S1G15
	X length ¹⁾	550 321	NEBM-M12W8-E- -N-S1G15

1) Max. 25 m

Motor controllers CMMS-AS, for servo motors

FESTO

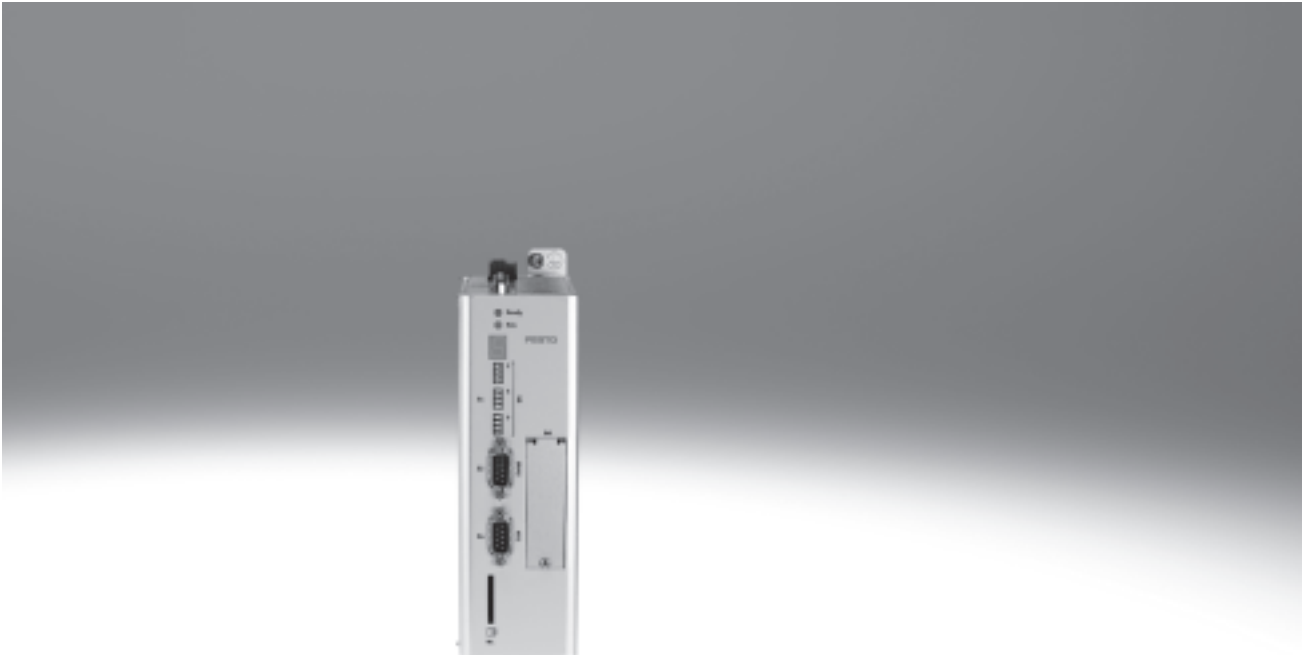

Motor controllers CMMS-AS, for servo motors



Key features

Comparison of motor controllers				
Motor controller		CMMS-AS	CMMP-AS	CMMS-ST
For motor type		Servo motor	Servo motor	Stepper motor
Torque at standstill	[Nm]	4.7	25	9.3
Peak torque	[Nm]	9.2	48	9.3
Speed	[rpm]	6,000	6,000	2,000
Position sets		63	255	63
Measuring system		Incremental/absolute	Incremental/absolute	Incremental
Extended I/O interface		4 working modes	Flexibly configurable	4 working modes
Notification of remaining distance		1 for n	Separate for all positions	1 for n
Torque reduction		No	Separate for all positions	No
Set linking		Linear	With branching	Linear
Safe stop		To EN 954-1 Cat3	To EN 954-1 Cat3	–

Performance characteristics

Compactness	Motion control
<ul style="list-style-type: none"> • Small dimensions • Full integration of all components for controller and power section, including RS232 and CANopen interface • Integrated brake chopper • Integrated EMC filters 	<ul style="list-style-type: none"> • Automatic actuation for a holding brake integrated in the motor • Adheres to the current CE and EN standards without additional external measures (motor cable length of up to 15 m) • Digital absolute shaft encoder in single-turn and multi-turn versions • Can be operated as a torque, speed or position controller • Integrated positioning controller • Time-optimised (trapezoidal) or jerk-free (S-shaped) positioning • Absolute and relative movements
<ul style="list-style-type: none"> • Point-to-point positioning with and without approximate positioning • Position synchronisation • Electronic gear unit • 63 position sets • 8 travel profiles • Wide range of homing methods 	

Fieldbus interfaces

Integrated:	Optional:	Input/output	Integrated sequence control
<p>Integrated:</p> 	<p>Optional:</p> 	<ul style="list-style-type: none"> • Freely programmable I/Os • High-resolution 12-bit analogue input • Jog/teach mode • Simple linking to a higher-level controller via I/O or fieldbus • Synchronous operation • Master/slave mode 	<ul style="list-style-type: none"> • Automatic sequence of position sets without a higher-level controller • Linear and cyclic position sequences • Adjustable delay times

Integrated safety functions

<ul style="list-style-type: none"> • Integrated “safe stop” as per EN 954-1 Cat3 in the basic unit • Protection against unexpected start-up • Two-channel disconnection of the output stage 	<ul style="list-style-type: none"> • Less external circuitry • Shorter response times in the event of an error • Faster restart, intermediate circuit remains charged 	<p>time pattern to this end. In between, the servo positioning controller independently interpolates the data values between two data points.</p>
--	--	---

Travel program

- Linking of any number of position sets into a travel program
- Further switching conditions for the travel program possible via digital inputs, for example
 - MC – motion complete
 - I/O – digital inputs

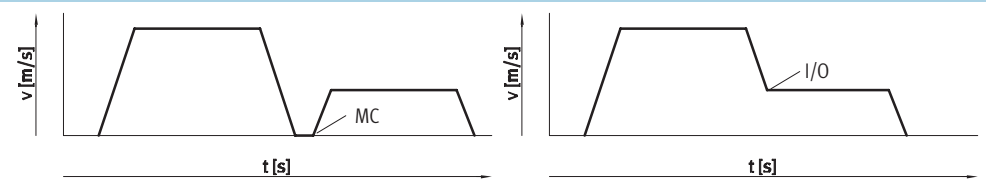

Motor controllers CMMS-AS, for servo motors

Key features

FCT software – Festo Configuration Tool

Software platform for electric drives from Festo

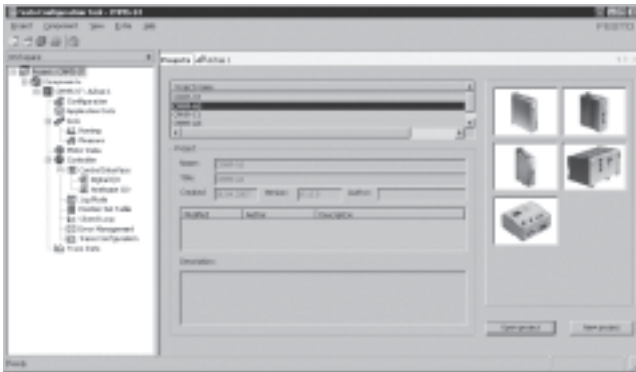

- All drives in a system can be managed and archived in a common project
- Project and data management for all supported device types
- Simple to use thanks to graphically-supported parameter entry
- Universal mode of operation for all drives
- Working offline at your desk or online at the machine

FHPP – Festo Handling and Positioning Profile

Optimised data profile

Festo has developed an optimised data profile, the “Festo Handling and Positioning Profile (FHPP)”, that is tailored to handling and positioning applications.

The FHPP data profile permits the actuation of Festo motor controllers, using a fieldbus interface, via standardised control and status bytes.

The following are defined, among others:

- Operating modes
- I/O data structure
- Parameter objects
- Sequence control

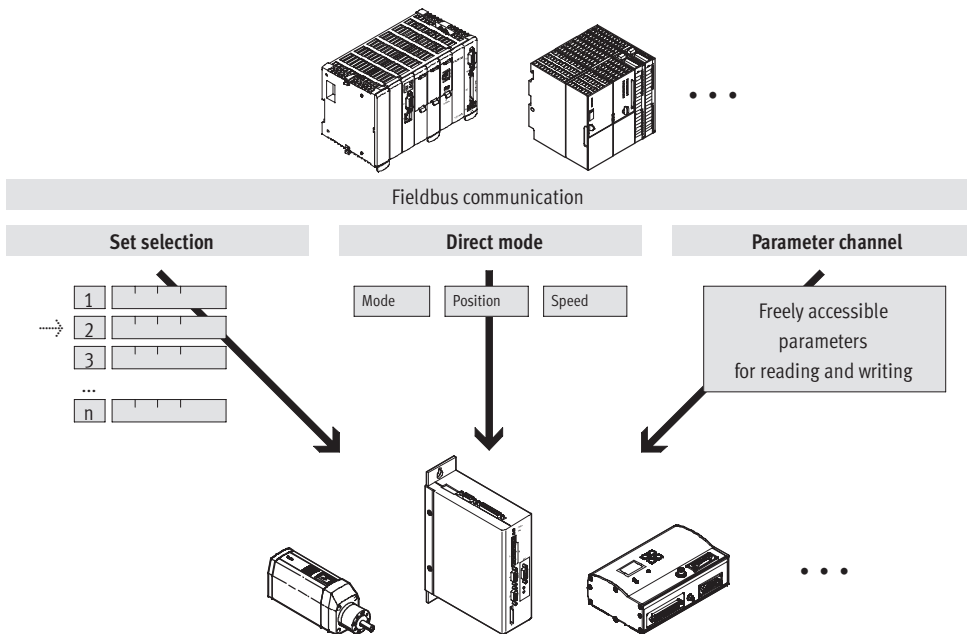

Motor controllers CMMS-AS, for servo motors

Type codes

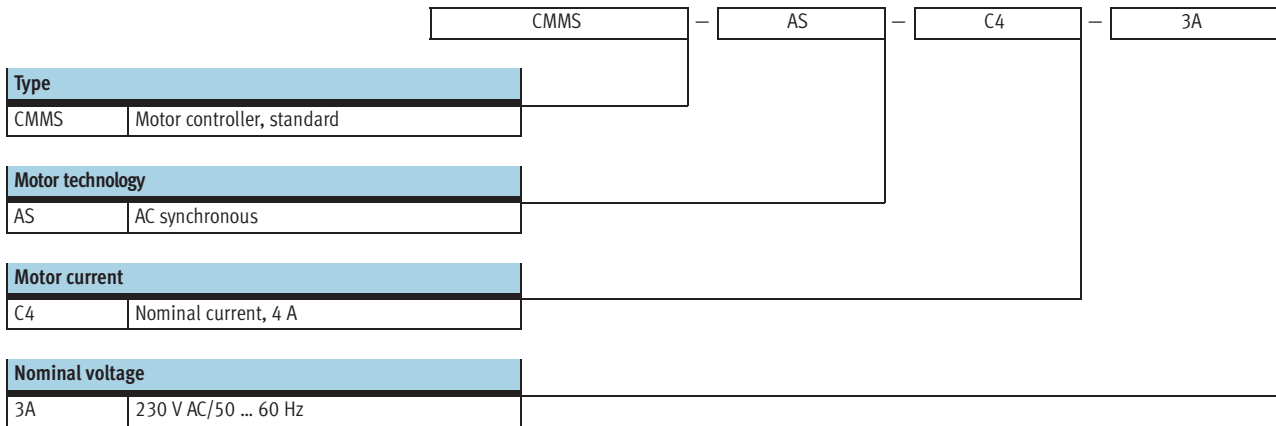

Motor controllers CMMS-AS, for servo motors

Technical data

FESTO

Fieldbus interfaces

CANopen

PROFIBUS DP

DeviceNet



General technical data	
Type of mounting	Screwed to a mounting plate
Display	7-segment display
Parameterisation interface	RS232 (9,600 ... 115,000 bits/s)
Encoder interface input	Setpoint position value as encoder signal EnDat V2.2
Encoder interface output	Actual value feedback via encoder signals in speed control mode Setpoint specification for downstream slave drive Resolution 4,096 ppr
Braking resistor, integrated [Ω]	230
Braking resistor, external [Ω]	100
Impedance of setpoint input [kΩ]	20
Pulse power of braking resistor [kVA]	0.7
Operating range of analogue outputs [V]	0 ... 10
Number of analogue outputs	1
Characteristics of analogue outputs	Short circuit-proof
Operating range of analogue inputs [V]	±10
Number of analogue inputs	1
Characteristics of analogue inputs	Differential inputs Configurable for speed Configurable for torque
Resolution of analogue outputs [Bit]	8
Mains filter	Integrated
Max. length of motor cable without external mains filter [m]	15
Product weight [g]	2,500

Technical data – Fieldbus interface					
Interfaces		I/O	CANopen	Profibus DP	DeviceNet
Operating range of logic inputs [V]		12 ... 30	–		
Number of digital logic inputs		14	–		
Characteristics of logic inputs		Freely configurable	–		
Number of digital logic outputs		5			
Characteristics of digital logic outputs		Freely configurable in some cases			
Process coupling		For 63 position sets			
Communication profile		–	DS301, FHPP	DP-V0 / FHPP	FHPP
		–	DS301, DSP402	Step7 functional modules	
Max. fieldbus transmission rate [Mbit/s]		–	1	12	0.5
Interface	Integrated	■	■	–	–
	Optional	–	–	■ → 47	■ → 47

Motor controllers CMMS-AS, for servo motors

Technical data

Electrical data		
General		
Nominal voltage phases		1
Nominal output current	[A]	4
Peak current	[A]	10
Max. peak current duration	[s]	2
Max. intermediate circuit voltage	[V DC]	380
Mains frequency	[Hz]	50 ... 60
Load supply		
Input voltage range	[V AC]	95 ... 255
Max. nominal input current	[A]	5
Rated output	[VA]	600
Peak output	[VA]	1,200
Logic supply		
Nominal voltage	[V DC]	24 ±20%
Nominal current	[A]	4 ... 5
Max. current of digital logic outputs	[mA]	100

Operating and environmental conditions	
Digital logic outputs	Not electrically isolated
Logic inputs	Electrically isolated
Protection class	IP20
Protective function	I ² t monitoring
	Intermediate circuit over-/undervoltage
	Short circuit in output stage
	Standstill monitoring
	Temperature monitoring
Ambient temperature	[°C] 0 ... +50
Storage temperature	[°C] -25 ... +70
Relative air humidity	[%] 0 ... 90 (non-condensing)
CE mark (see declaration of conformity)	To EU Low Voltage Directive
Safe stop	To EN 954-1 Cat3

View of motor controller

From the front

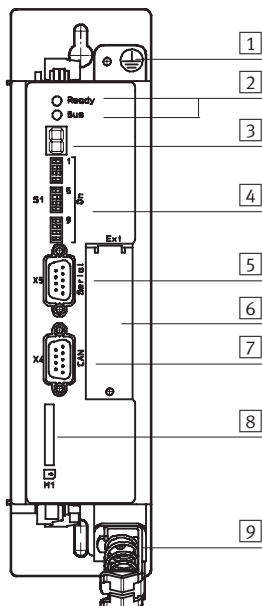

- 1 Earthing
- 2 Ready/bus LED
- 3 Status display
- 4 Fieldbus settings and boot loader
- 5 Interface: RS232/RS485
- 6 Technology module (optional)
- 7 Interface: CAN bus
- 8 SD memory card
- 9 Screened connection

Motor controllers CMMS-AS, for servo motors

Technical data

FESTO

View of motor controller

From above

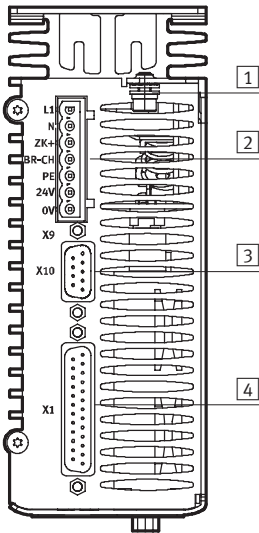

- 1 Earthing screw
- 2 Power supply
- 3 Increment generator output
- 4 I/O interface

From underneath

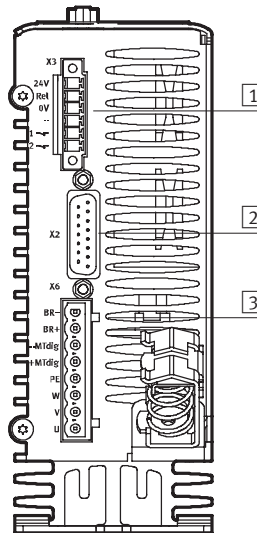

- 1 Safe stop
- 2 Increment generator input
- 3 Motor connection

Installation clearance for motor controller

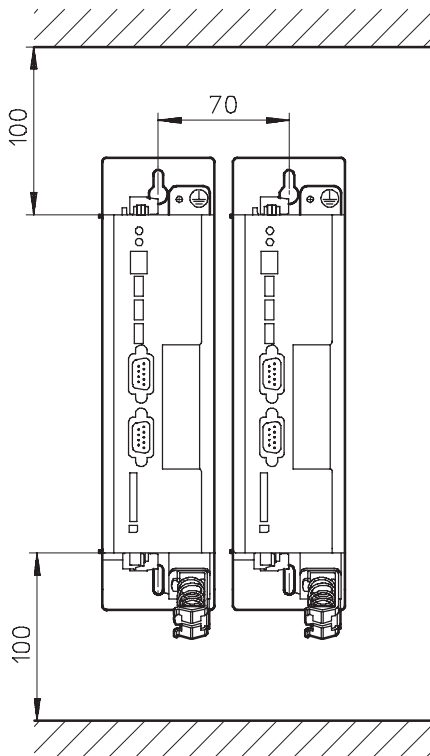

Motor controllers CMMS-AS, for servo motors

Technical data

Dimensions

Download CAD data → www.festo.com

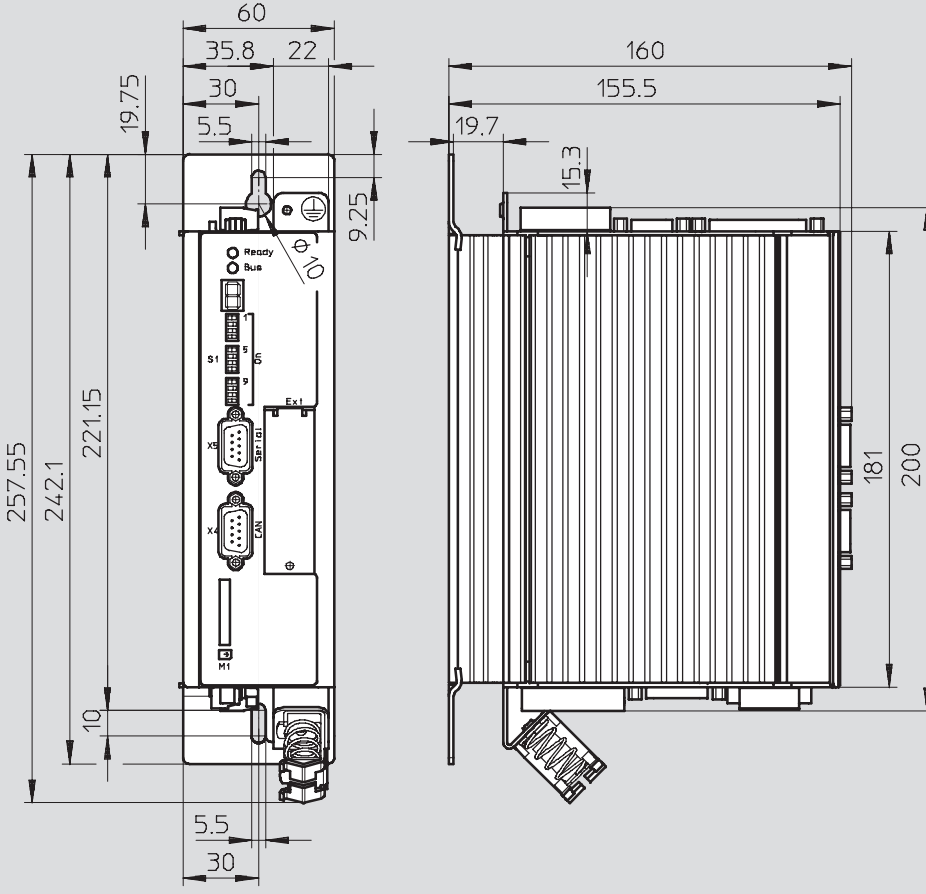

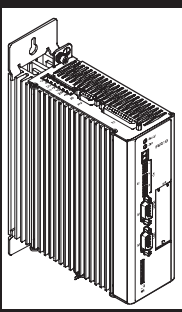

Ordering data



	Brief description	Part No.	Type
	The plug assortment NEKM (→ 47) and the operator package (→ 48) are included in the scope of delivery.	552 741	CMMS-AS-C4-3A

Motor controllers CMMS-AS, for servo motors

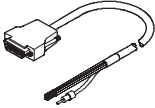
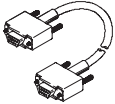
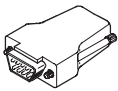
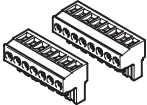
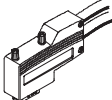
Accessories

FESTO

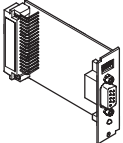
Ordering data – Cables and plugs				
	Brief description	Cable length [m]	Part No.	Type
	Control cable, for I/O interface to any controller	2.5	552 254	NEBC-S1G25-K-2.5N-LE26
	Programming cable	1.5	160 786	PS1-ZK11-NULLMODEM-1,5M
	Encoder plug	–	564 264	NECC-A-S-S1G9-C2M
	Plug assortment, comprising plug for power supply and plug for motor connection. The plug assortment is included in the scope of delivery	–	560 504	NEKM-C-4
	Plug for Profibus interface	–	533 780	FBS-SUB-9-WS-PB-K
	Plug for DeviceNet interface	–	525 635	FBSD-KL-2X5POL

Ordering data – Plug-in cards				
	Brief description	Part No.	Type	
	Interface, for Profibus interface	547 450	CAMC-PB	
	Interface, for DeviceNet interface	547 451	CAMC-DN	
	Memory card, for data backup and firmware downloads	562 211	CAMC-M-S-F2-V1	

Motor controllers CMMS-AS, for servo motors

Accessories

Ordering data – Software and documentation		
	Brief description	Part No. Type
	Operator package contains: – CD-ROM – with manual for CMMS-AS, in de, en, es, fr, it, sv – with FCT (Festo Configuration Tool) configuration software, in de, en – Brief description This package is included in the scope of delivery	559 868 GSIB-CMMS-AS

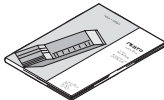
Ordering data – Documentation ¹⁾				
	Language	Part No. Type	Part No. Type	
		for motor controller		Festo Handling and Positioning Profile (FHPP) for the motor controller family CMM...
	DE	564 227 P.BE-CMMS-AS-3A-HW-DE	555 695 P.BE-CMM-FHPP-SW-DE	
	EN	564 228 P.BE-CMMS-AS-3A-HW-EN	555 696 P.BE-CMM-FHPP-SW-EN	
	ES	564 229 P.BE-CMMS-AS-3A-HW-ES	555 697 P.BE-CMM-FHPP-SW-ES	
	FR	564 230 P.BE-CMMS-AS-3A-HW-FR	555 698 P.BE-CMM-FHPP-SW-FR	
	IT	564 231 P.BE-CMMS-AS-3A-HW-IT	555 699 P.BE-CMM-FHPP-SW-IT	
	SV	564 232 P.BE-CMMS-AS-3A-HW-SV	555 700 P.BE-CMM-FHPP-SW-SV	
		for CANopen interface		for Profibus interface
	DE	554 351 P.BE-CMMS-CO-SW-DE	554 345 P.BE-CMMS-FHPP-PB-SW-DE	
	EN	554 352 P.BE-CMMS-CO-SW-EN	554 346 P.BE-CMMS-FHPP-PB-SW-EN	
	ES	554 353 P.BE-CMMS-CO-SW-ES	554 347 P.BE-CMMS-FHPP-PB-SW-ES	
	FR	554 354 P.BE-CMMS-CO-SW-FR	554 348 P.BE-CMMS-FHPP-PB-SW-FR	
	IT	554 355 P.BE-CMMS-CO-SW-IT	554 349 P.BE-CMMS-FHPP-PB-SW-IT	
	SV	554 356 P.BE-CMMS-CO-SW-SV	554 350 P.BE-CMMS-FHPP-PB-SW-SV	
		for DeviceNet interface		
DE	554 357 P.BE-CMMS-FHPP-DN-SW-DE			
EN	554 358 P.BE-CMMS-FHPP-DN-SW-EN			
ES	554 359 P.BE-CMMS-FHPP-DN-SW-ES			
FR	554 360 P.BE-CMMS-FHPP-DN-SW-FR			
IT	554 361 P.BE-CMMS-FHPP-DN-SW-IT			
SV	554 362 P.BE-CMMS-FHPP-DN-SW-SV			

1) Manual in paper form is not included in the scope of delivery

Motor controllers CMMP-AS, for servo motors







Motor controllers CMMP-AS, for servo motors

Key features

Comparison of motor controllers				
Motor controller		CMMP-AS	CMMS-AS	CMMS-ST
For motor type		Servo motor	Servo motor	Stepper motor
Torque at standstill	[Nm]	25	4.7	9.3
Peak torque	[Nm]	48	9.2	9.3
Speed	[rpm]	6,000	6,000	2,000
Position sets		255	63	63
Measuring system		Incremental/absolute	Incremental/absolute	Incremental
Extended I/O interface		Flexibly configurable	4 working modes	4 working modes
Notification of remaining distance		Separate for all positions	1 for n	1 for n
Torque reduction		Separate for all positions	No	No
Set linking		With branching	Linear	Linear
Safe stop		To EN 954-1 Cat3	To EN 954-1 Cat3	–

Performance characteristics

Compactness	Motion control
<ul style="list-style-type: none"> • Small dimensions • Full integration of all components for controller and power section, including RS232 and CANopen interface • Integrated brake chopper • Integrated EMC filters 	<ul style="list-style-type: none"> • Automatic actuation for a holding brake integrated in the motor • Adheres to the current CE and EN standards without additional external measures (motor cable length of up to 25 m) • Digital absolute shaft encoder in single-turn and multi-turn versions • Can be operated as a torque, speed or position controller • Integrated positioning controller • Time-optimised (trapezoidal) or jerk-free (S-shaped) positioning
<ul style="list-style-type: none"> • Absolute and relative movements • Point-to-point positioning with and without approximate positioning • Position synchronisation • Electronic gear unit • 255 position sets • Wide range of homing methods 	

Fieldbus interfaces	Input/output	Integrated sequence control
<p>Integrated:</p> 	<ul style="list-style-type: none"> • Freely programmable I/Os • High-resolution 16-bit analogue input • Jog/teach mode • Simple linking to a higher-level controller via I/O or fieldbus • Synchronous operation • Master/slave mode 	<ul style="list-style-type: none"> • Automatic sequence of position sets without a higher-level controller • Linear and cyclic position sequences • Adjustable delay times • Branches and wait positions • Overlapping restart possible during the movement
<p>Optional:</p>   		

Integrated safety functions	Interpolating multi-axis movement
<ul style="list-style-type: none"> • Integrated “safe stop” as per EN 954-1 Cat3 in the basic unit • Protection against unexpected start-up • Two-channel disconnection of the output stage 	<ul style="list-style-type: none"> • With a suitable controller, the CMMP-AS can perform path movements with interpolation via CANopen or Sercos. The controller specifies setpoint position values in a fixed time pattern to this end. In between, the servo positioning controller independently interpolates the data values between two data points.
<ul style="list-style-type: none"> • Less external circuitry • Shorter response times in the event of an error • Faster restart, intermediate circuit remains charged 	

Travel program

- Linking of any number of position sets into a travel program
- Further switching conditions for the travel program possible via digital inputs, for example
 - MC – motion complete
 - I/O – digital inputs

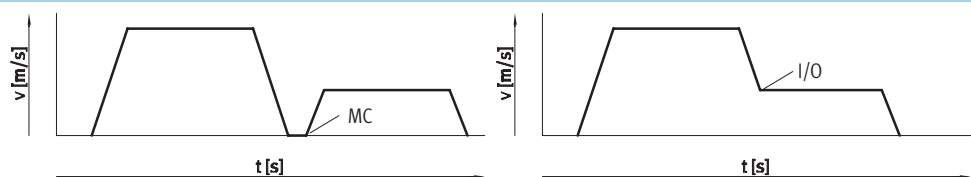

Motor controllers CMMP-AS, for servo motors

Key features

FCT software – Festo Configuration Tool

Software platform for electric drives from Festo

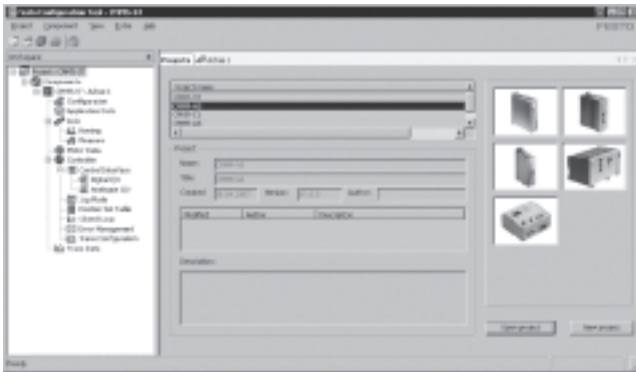

- All drives in a system can be managed and archived in a common project
- Project and data management for all supported device types
- Simple to use thanks to graphically-supported parameter entry
- Universal mode of operation for all drives
- Working offline at your desk or online at the machine

FHPP – Festo Handling and Positioning Profile

Optimised data profile

Festo has developed an optimised data profile, the “Festo Handling and Positioning Profile (FHPP)”, that is tailored to handling and positioning applications.

The FHPP data profile permits the actuation of Festo motor controllers, using a fieldbus interface, via standardised control and status bytes.

- The following are defined, among others:
- Operating modes
 - I/O data structure
 - Parameter objects
 - Sequence control

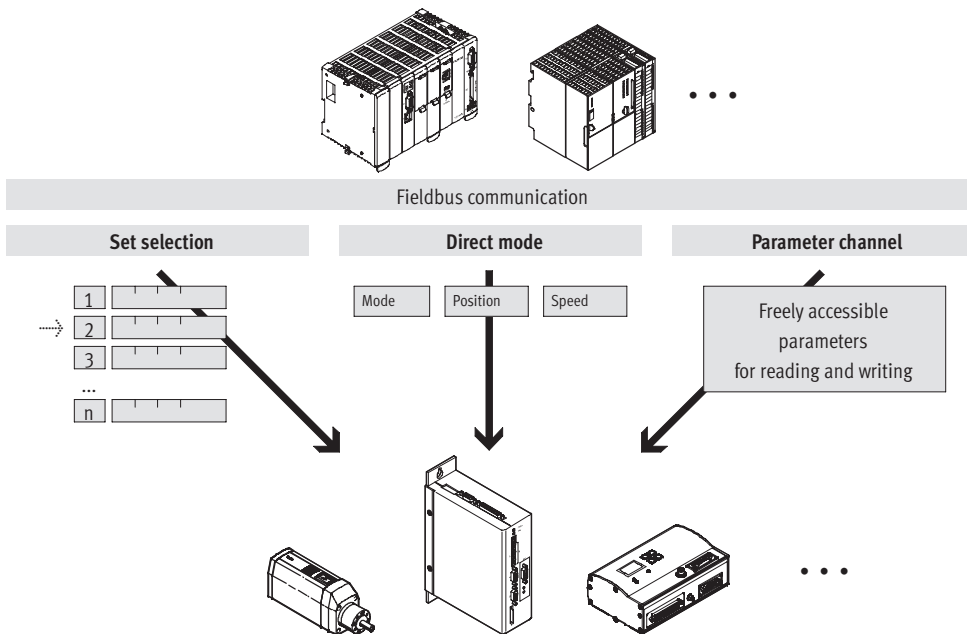

Motor controllers CMMP-AS, for servo motors

Type codes

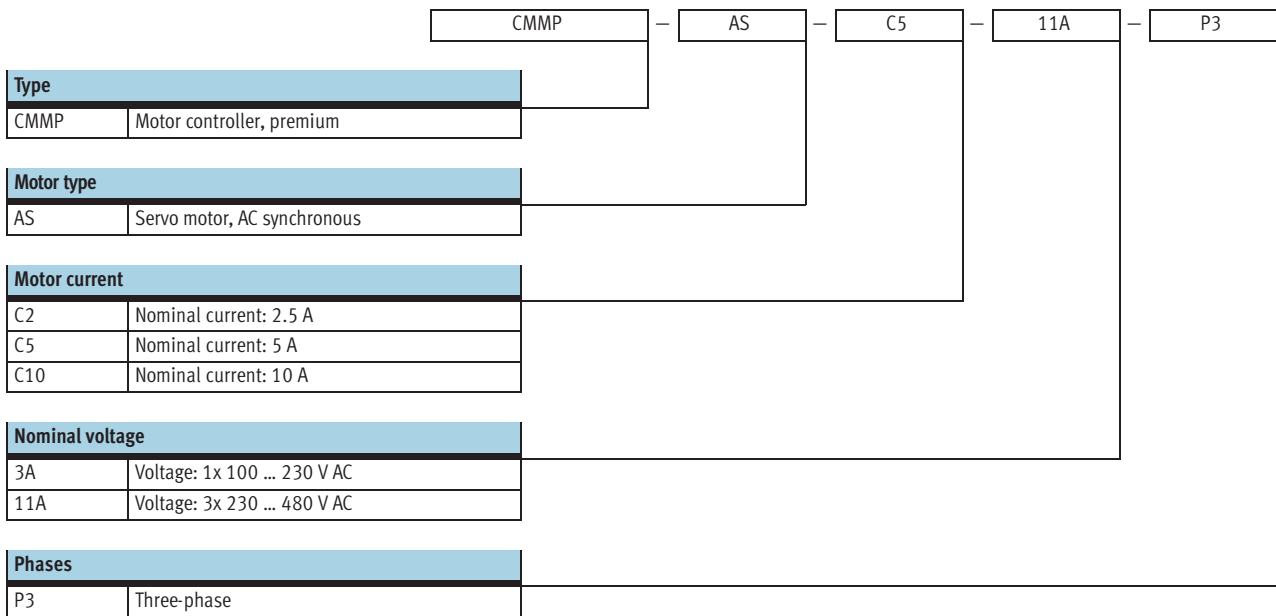

Motor controllers CMMP-AS, for servo motors

Technical data

FESTO

Fieldbus interfaces

CANopen



PROFIBUS

DeviceNet

SERCOS interface



General technical data				
CMMP-AS-	C2-3A	C5-3A	C5-11A-P3	C10-11A-P3
Type of mounting	Screwed to a mounting plate			
Output frequency [Hz]	0 ... 1,000			
Display	7-segment display			
Parameterisation interface	RS232 (9,600 ... 115,000 bits/s)			
Encoder interface input	As speed/position specification for the slave drive in synchronous mode			
	Encoder signal setpoint speed			
	EnDat V2.2			
Encoder interface output	RS422			
	Actual value feedback via encoder signals in speed control mode			
	Setpoint specification for downstream slave drive			
Brake resistor, integrated [Ω]	165	110	68	
Pulse power of braking resistor [kVA]	1.1	1.6	8.5	
Operating range of analogue outputs [V]	±10			
Operating range of analogue inputs [V]	±10			
Number of analogue outputs	2			
Number of analogue inputs	3			
Resolution of analogue outputs	9-bit			
Characteristics of logic inputs	Freely configurable			
Characteristics of analogue outputs	Short circuit-proof			
Characteristics of analogue inputs	Differential inputs			
	Configurable for speed			
	Configurable for current			
Characteristics of digital logic outputs	Freely configurable in some cases			
Mains filter	Integrated			
Max. length of motor cable without external mains filter [m]	25			
Product weight [g]	2,000	2,100	3,700	

Technical data – Fieldbus interface				
Interfaces	I/O	CANopen	Profibus DP	DeviceNet
Operating range of logic inputs [V]	8 ... 30	–	–	–
Number of digital logic inputs	10	–	–	–
Number of digital logic outputs	5	–	–	–
Process coupling	For 255 position sets	–	–	–
Communication profile	–	DS301, FHPP	DP-V0 / FHPP	FHPP
	–	DS301, DSP402	Step7 functional modules	
Max. fieldbus transmission rate [Mbit/s]	–	1	12	0.5
Interface	Integrated	■	■	–
	Optional	–	–	■ → 58

Motor controllers CMMP-AS, for servo motors

Technical data

Electrical data				
CMMP-AS-	C2-3A	C5-3A	C5-11A-P3	C10-11A-P3
General				
Nominal voltage phases	1		3	
Nominal current [A]	2.5	5	5	10
Peak current [A]	5	10	15	20
Max. peak current duration [s]	5		3	
Max. intermediate circuit voltage [V DC]	380		560	
Mains frequency [Hz]	50 ... 60			
Load supply				
Input voltage range [V AC]	100 ... 230		3x 230 ... 480	
Max. nominal input current [A]	3	6	5.5	11
Rated output [VA]	500	1,000	3,000	6,000
Peak output [VA]	1,000	2,000	6,000	12,000
Logic supply				
Nominal voltage [V DC]	24 ±20%			
Nominal current [A]	0.55/2.55 ¹⁾	0.65/2.65 ¹⁾	1/3 ¹⁾	
Max. current of digital logic outputs [mA]	100			

1) Max. current with brake

Operating and environmental conditions	
Digital logic outputs	Electrically separated
Logic inputs	Electrically separated
Protection class	IP20
Ambient temperature [°C]	0 ... +50
Storage temperature [°C]	-25 ... +70
Relative humidity [%]	0 ... 90 (non-condensing)
CE mark (see declaration of conformity)	To EU Low Voltage Directive
Safe stop	To EN 954-1 KAT3

View of motor controller

From the front

CMMP-AS-...-3A

CMMP-AS-...-11A-P3

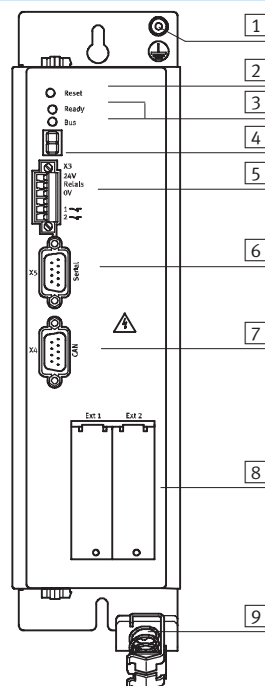
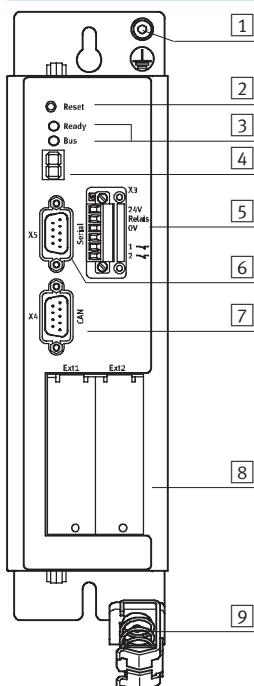

- 1 Earthing
- 2 Reset button
- 3 Ready/bus LED
- 4 Status display
- 5 Control connection for relay driver supply
- 6 Interface: RS232/RS485
- 7 Interface: CAN bus
- 8 Technology module slot
- 9 Screened connection

Motor controllers CMMP-AS, for servo motors

Technical data

View of motor controller

From above

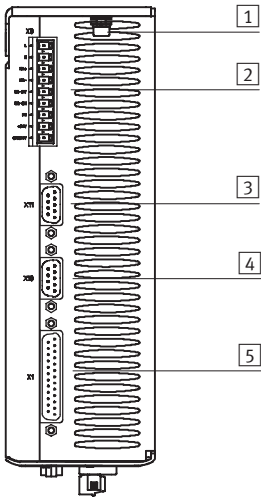

- 1 Earthing screw
- 2 Power supply
- 3 Increment generator output
- 4 Increment generator input
- 4 I/O interface

From below

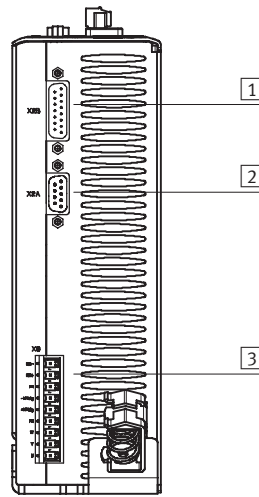

- 1 Encoder connection
- 2 Resolver connection
- 3 Motor connection

Installation clearance for motor controller

CMMP-AS-...-3A

CMMP-AS-...-11A-P3

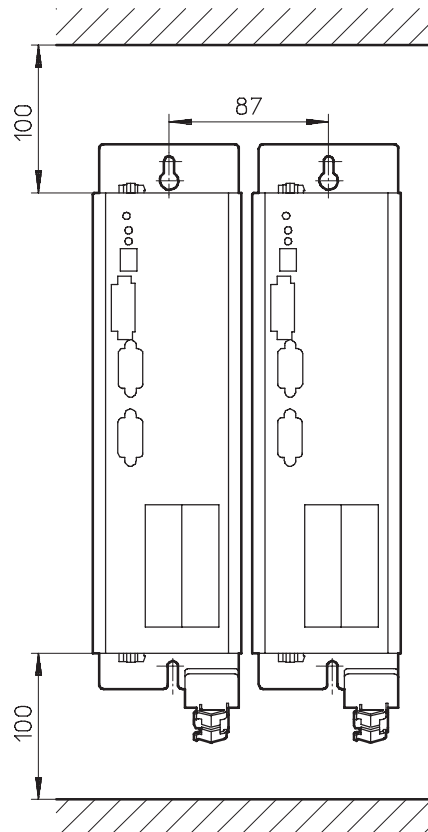
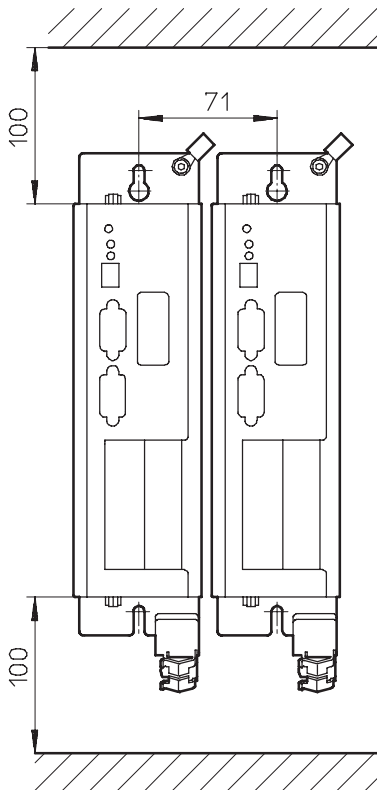

Motor controllers CMMP-AS, for servo motors

Technical data

Dimensions

Download CAD data → www.festo.com

CMMP-AS-...-3A

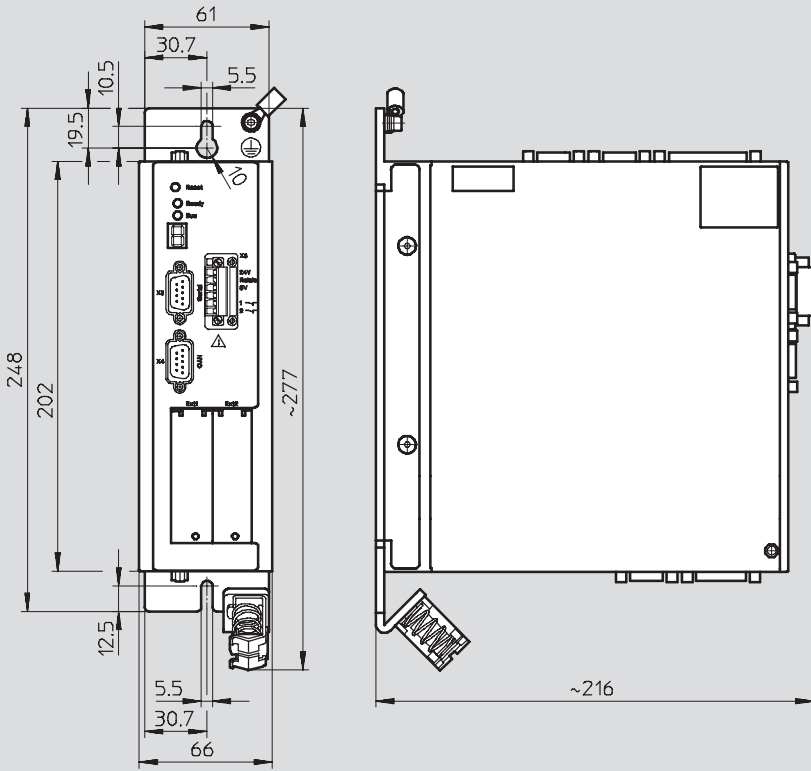

CMMP-AS-...-11A-P3

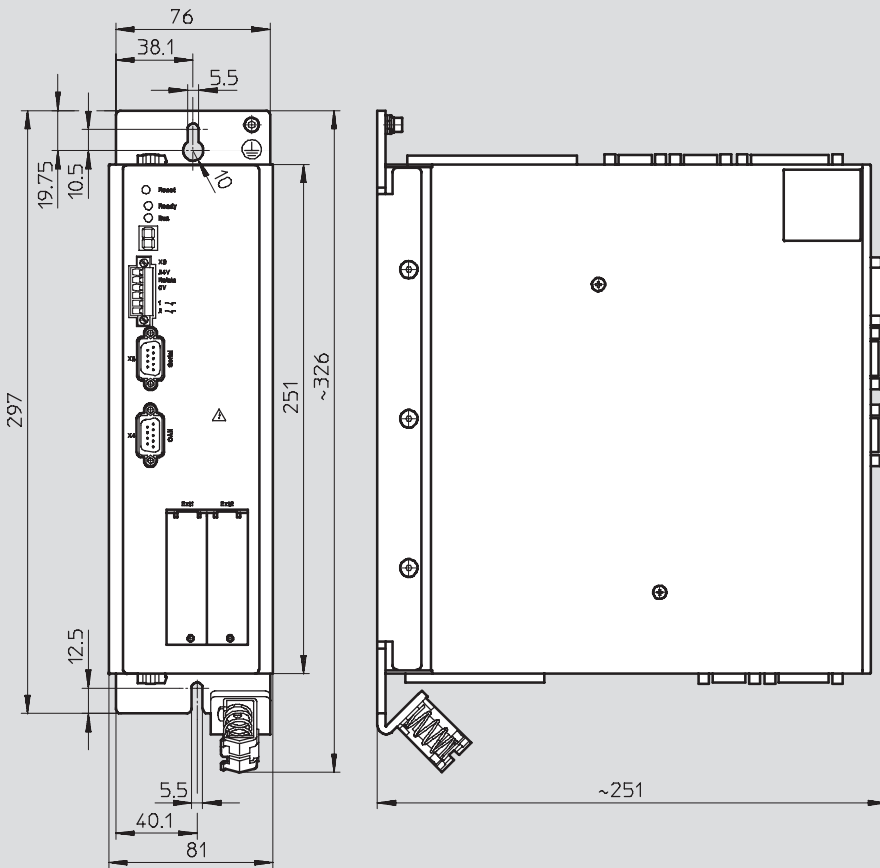

Motor controllers CMMP-AS, for servo motors

Technical data

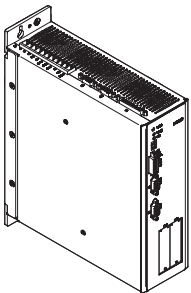
Ordering data		Part No.	Type
	Brief description The plug range NEKM (→ 58) and the operating package (→ 59) are included in the scope of delivery.	550 041	CMMP-AS-C2-3A
		550 042	CMMP-AS-C5-3A
		551 023	CMMP-AS-C5-11A-P3
		551 024	CMMP-AS-C10-11A-P3

Accessories

Braking resistance BRW

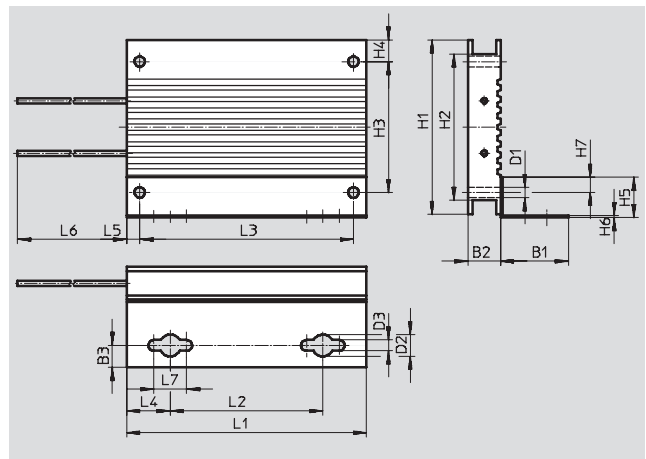



Dimensions and ordering data										
Size	B1	B2	B3	D1	D2	D3	H1	H2	H3	H4
250	31	15	10	5	10	5	80	67	60	10
500										

Size	H5	H6	H7	L1	L2	L3	L4	L5	L6	L7
250	18.5	1	7	110	70	98	20	6	50	15
500				216	176	204				

Size	Resistance value	Nominal power	Protection class	Weight	Part No.	Type
	[Ω]	[W]		[g]		
250	72±5%	100	IP65	280	538 940	BRW-250-072
500	72±5%	200	IP65	550	538 941	BRW-500-072

Motor controllers CMMP-AS, for servo motors

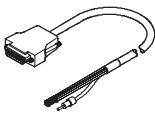
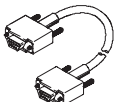
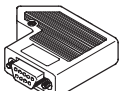
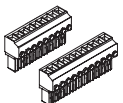
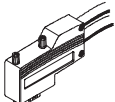
Accessories

Ordering data – Cables and plugs				
	Brief description	Cable length [m]	Part No.	Type
	Control cable, for I/O interface to any controller	2.5	552 254	NEBC-S1G25-K-2.5N-LE26
	Programming cable	1.5	160 786	PS1-ZK11-NULLMODEM-1,5M
	Encoder plug	–	552 274	NECC-S-S1G9-C2M
	Plug range for CMMP-AS-...-3A	–	552 255	NEKM-C-2 ¹⁾
	Plug range for CMMP-AS-...-11A-P3	–	552 256	NEKM-C-3 ¹⁾
	Plug for Profibus interface	–	533 780	FBS-SUB-9-WS-PB-K
	Plug for DeviceNet interface	–	525 635	FBSD-KL-2X5POL

1) Comprising plug for power supply and plug for motor connection. The plug range is included in the scope of delivery

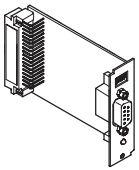
Ordering data – Plug-in cards			
	Brief description	Part No.	Type
	For Profibus interface	547 450	CAMC-PB
	For DeviceNet interface	547 451	CAMC-DN
	For Sercos interface	552 258	CAMC-SC

Motor controllers CMMP-AS, for servo motors

Accessories

FESTO

Ordering data – Software and documentation			
	Brief description	Part No.	Type
	Operating package contains: – CD-ROM – with user documentation for CMMP-AS, in de, en, es, fr, it, sv – with FCT (Festo Configuration Tool) configuration software, in de, en – Brief description This package is included in the scope of delivery	558 329	PBP-CMMP-AS

Ordering data – Documentation ¹⁾						
	Language	Part No. Type		Part No. Type		
		for motor controller CMMP-AS-...-3A		for motor controller CMMP-AS-...-11A-P3		
	DE	557 325	P.BE-CMMP-AS-3A-HW-DE	557 331	P.BE-CMMP-AS-11A-HW-DE	
	EN	557 326	P.BE-CMMP-AS-3A-HW-EN	557 332	P.BE-CMMP-AS-11A-HW-EN	
	ES	557 327	P.BE-CMMP-AS-3A-HW-ES	557 333	P.BE-CMMP-AS-11A-HW-ES	
	FR	557 328	P.BE-CMMP-AS-3A-HW-FR	557 334	P.BE-CMMP-AS-11A-HW-FR	
	IT	557 329	P.BE-CMMP-AS-3A-HW-IT	557 335	P.BE-CMMP-AS-11A-HW-IT	
	SV	557 330	P.BE-CMMP-AS-3A-HW-SV	557 336	P.BE-CMMP-AS-11A-HW-SV	
		Festo Handling and Positioning Profile (FHPP) for the motor controller family CMM...				
	DE	555 695	P.BE-CMM-FHPP-SW-DE			
	EN	555 696	P.BE-CMM-FHPP-SW-EN			
	ES	555 697	P.BE-CMM-FHPP-SW-ES			
	FR	555 698	P.BE-CMM-FHPP-SW-FR			
	IT	555 699	P.BE-CMM-FHPP-SW-IT			
	SV	555 700	P.BE-CMM-FHPP-SW-SV			
		for Profibus interface		for DeviceNet interface		
DE	557 337	P.BE-CMMP-FHPP-PB-SW-DE	557 349	P.BE-CMMP-FHPP-DN-SW-DE		
EN	557 338	P.BE-CMMP-FHPP-PB-SW-EN	557 350	P.BE-CMMP-FHPP-DN-SW-EN		
ES	557 339	P.BE-CMMP-FHPP-PB-SW-ES	557 351	P.BE-CMMP-FHPP-DN-SW-ES		
FR	557 340	P.BE-CMMP-FHPP-PB-SW-FR	557 352	P.BE-CMMP-FHPP-DN-SW-FR		
IT	557 341	P.BE-CMMP-FHPP-PB-SW-IT	557 353	P.BE-CMMP-FHPP-DN-SW-IT		
SV	557 342	P.BE-CMMP-FHPP-PB-SW-SV	557 354	P.BE-CMMP-FHPP-DN-SW-SV		
	for CANopen interface		for Sercos interface			
DE	557 343	P.BE-CMMP-CO-SW-DE	557 361	P.BE-CMMP-SC-SW-DE		
EN	557 344	P.BE-CMMP-CO-SW-EN	557 362	P.BE-CMMP-SC-SW-EN		
ES	557 345	P.BE-CMMP-CO-SW-ES	557 363	P.BE-CMMP-SC-SW-ES		
FR	557 346	P.BE-CMMP-CO-SW-FR	557 364	P.BE-CMMP-SC-SW-FR		
IT	557 347	P.BE-CMMP-CO-SW-IT	557 365	P.BE-CMMP-SC-SW-IT		
SV	557 348	P.BE-CMMP-CO-SW-SV	557 366	P.BE-CMMP-SC-SW-SV		

1) User documentation in paper form is not included in the scope of delivery

Motor units MTR-DCI, intelligent servo motors

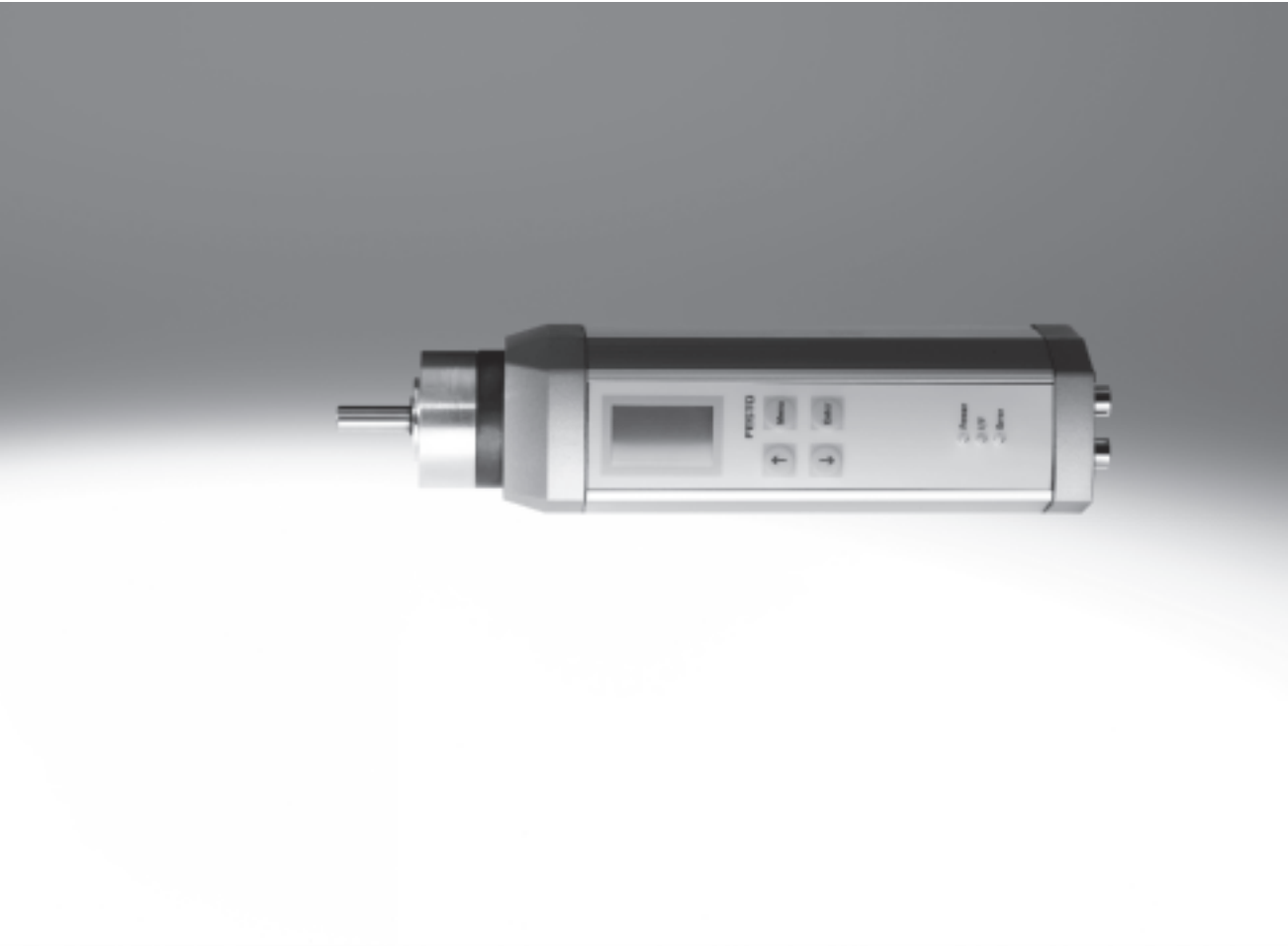

Motor units MTR-DCI, intelligent servo motors

Key features

FESTO

General information

The motor unit MTR-DCI is an innovative motor with integrated power electronics for positioning tasks.

Four components in one housing

Integrated in the MTR-DCI are the motor, gear unit, controller and power electronics. This means that there is no need for a control cabinet or extensive cabling.

Reliable

The integrated power electronics and controller removes the need for motor cables and improves the electromagnetic compatibility. Additional monitoring functions are integrated.

Uncomplicated

The complete commissioning process can be performed directly on the MTR-DCI via the optional LCD display or on a PC via the user-friendly menus in the FCT (Festo Configuration Tool). No matter which approach is used, all parameters are continuously controlled.

At a glance

- Compact design
- Smooth profile prevents the ingress of dirt
- DC motor with planetary gear unit and encoder
- Gear unit ratio: 7:1; 14:1, 22:1
- Protection class IP54

Positioning functionality

- 16 traversing records (including homing)
- Constant acceleration and braking
- Positioning control

Protective functions

- Temperature monitoring
- Current monitoring
- Voltage failure detection
- Following error monitoring
- Software end-position detection

Easy actuation via

- I/O interface
- Profibus
- CANopen
- DeviceNet



CANopen

DeviceNet

- 1 Control panel with integrated display (optional)
- 2 Input for reference limit switches
- 3 RS232 interface
- 4 Operator interface: I/O interface
- 5 Power supply
- 6 Gear unit



Typical applications

Adjusting sorting conveyors

Programming formats for paper or foil cutting machines

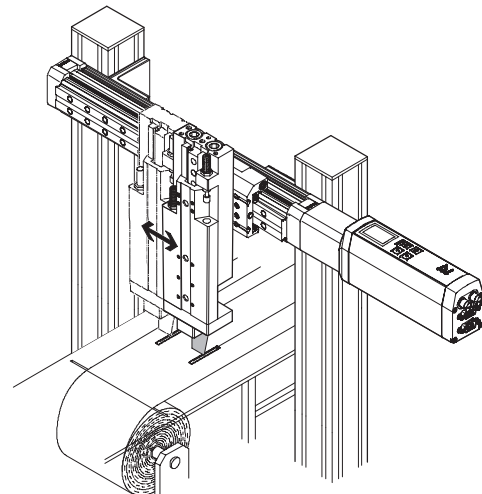
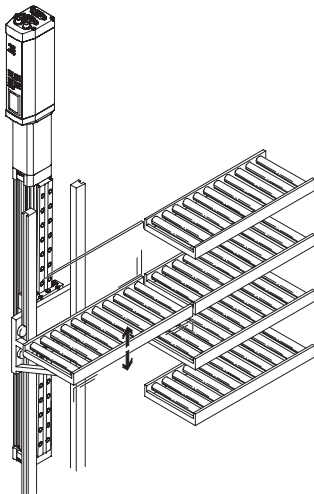

Motor units MTR-DCI, intelligent servo motors

FESTO

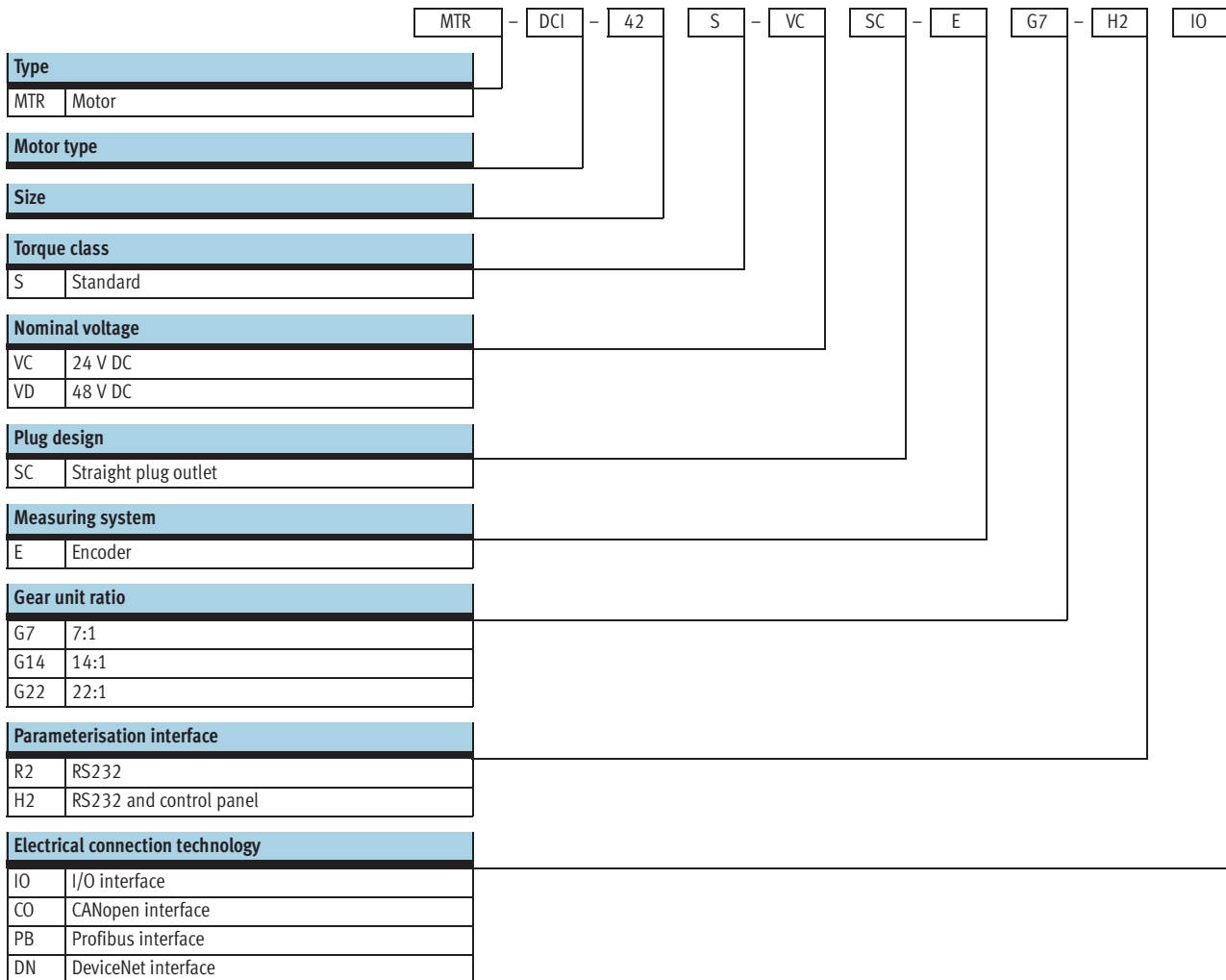

Type codes



Motor units MTR-DCI, intelligent servo motors

Technical data

FESTO

-  Size
32 ... 62 mm
-  Voltage
24, 48 V DC

Fieldbus interfaces



CANopen

DeviceNet



General technical data				
Size	32	42	52	62
Rotary position generator	Optical encoder			
No. of increments/revolution	300 (1,200) ¹⁾	500 (2,000) ¹⁾		
Controller operating mode	PWM MOSFET power amplifier			
Display resolution	128 x 64 pixels			
Type of mounting	Can be bolted on or clamped to gearing unit flange			
Gearing unit type	Planetary gearing			
Gear unit ratio	G7	6.75 (7:1); 1-stage		
	G14	13.73 (14:1); 2-stage		
	G22	-		22.21 (22:1); 2-stage

1) Internal 4-fold evaluation

Electrical data – Motor				
Size	32	42	52	62
Nominal voltage [V DC]	24 ±10%			48 -10%/+5%
Nominal current (motor) [A]	0.73	2	5	6.19
Peak current [A]	2.1	3.8	7.7	20
Motor constant [Ncm/A]	4.5	6.1	6.4	12.1
Nominal power (motor) [W]	17	48	122	316
Max. current (digital logic outputs) [mA]	200		60	
Parameterisation interface	RS232; 9,600 baud			

Mechanical data – Motor									
Size	32		42		52		62		
Gear unit ratio	G7	G14	G7	G14	G7	G14	G7	G14	G22
Gearing unit output speed [rpm]	481	237	444	218	444	218	504	248	153
Gearing unit torsional backlash [°]	≤ 1.9	≤ 1.55	≤ 1.3	≤ 0.95	≤ 1.1	≤ 0.75	≤ 1	≤ 1.5	≤ 1.5
Gearing unit output torque [Nm]	0.15	0.29	0.59	1.13	1.62	3.08	3.78	7.2	11.66
Gearing unit efficiency	0.75	0.7	0.8	0.75	0.8	0.75	0.8	0.75	0.75
Mass moment of inertia (rotor) [kg cm ²]	0.024		0.323		1.209		3.3		
Mass moment of inertia (gearing unit) [kg cm ²]	0.00089	0.00149	0.00235	0.00441	0.01132	0.01711	0.017	0.035	0.022
Radial shaft load [N]	40	70	160	230	200	320	240	360	360
Axial shaft load [N]	10	20	50	80	60	100	50	70	70
Product weight [kg]	0.72	0.74	1.72	1.83	3.1	3.3	7.6	8.0	8.0

Motor units MTR-DCI, intelligent servo motors

Technical data

FESTO

Operating and environmental conditions				
Size	32	42	52	62
Digital logic outputs	Not electrically isolated		Electrically isolated	
Insulation protection class to VDE 60034	F			
Protection class	IP54			
Protective functions	I ² T monitoring			
	Following error monitoring			
	Software end position detection			
	Voltage failure detection			
	Current monitoring			
Temperature monitoring: Silicon absolute temperature sensor, switches off at temperatures >70 °C				
Ambient temperature [°C]	0 ... +50			
Storage temperature [°C]	-25 ... +60			
Relative air humidity [%]	0 ... 95 (non-condensing)			
CE mark (see declaration of conformity)	In accordance with EU EMC directive			
Certification	C-Tick			
Note on materials	Contains paint wetting impairment substances			

Materials	
Motor unit housing	Anodised aluminium
Motor unit cover	Aluminium, precision casting, coated (size 62 milled)

Technical data – I/O/fieldbus interface				
Type	MTR-DCI-...-IO	MTR-DCI-...-CO	MTR-DCI-...-PB	MTR-DCI-...-DN
Interface	I/O interface for 15 traversing records and homing	CANopen	Profibus DP	DeviceNet
Number of digital logic inputs	6	–	–	–
Number of digital logic outputs	2	–	–	–
Max. current of digital logic outputs (size)	32/42	200	–	–
	52/62	60	–	–
Bus terminating resistor ¹⁾	–	Not integrated in the device	Not integrated in the device	Not integrated in the device
Communication profile	–	DS301 / FHPP	DP-V0/V1 / FHPP	FHPP
	–	DS301; DSP402	Step7 functional modules	Device type 0C _n
Max. fieldbus baud rate [kbps]	–	1,000	12,000	500

1) Details of bus terminating resistor → 70

Motor units MTR-DCI, intelligent servo motors

Technical data

Torque M as a function of rotational speed n

Size 32

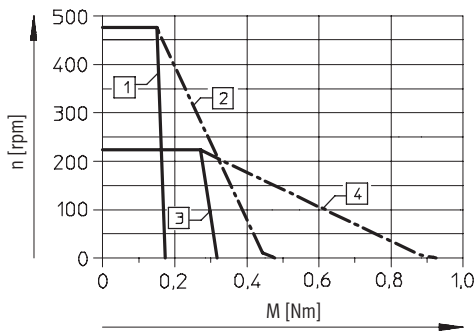

Size 42

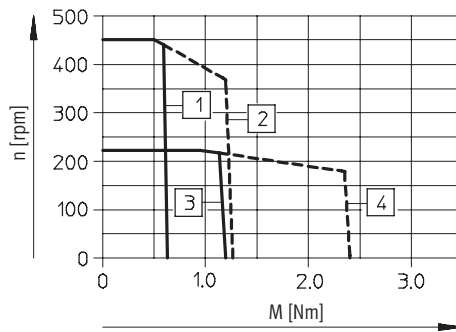

Size 52

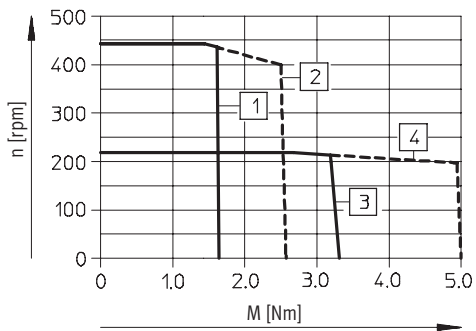

Size 62

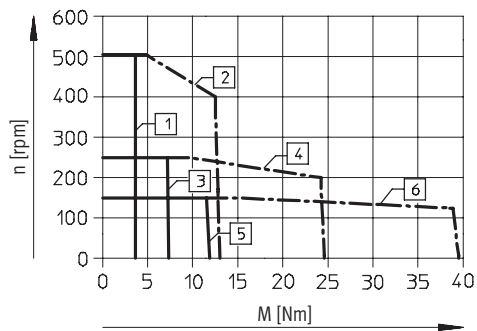

Gear unit ratio 7:1

- 1 Torque, nom.
- 2 Torque, max.

Gear unit ratio 14:1

- 3 Torque, nom.
- 4 Torque, max.

Gear unit ratio 22:1

- 5 Torque, nom.
- 6 Torque, max.

Motor units MTR-DCI, intelligent servo motors

Technical data

FESTO

Pin allocation

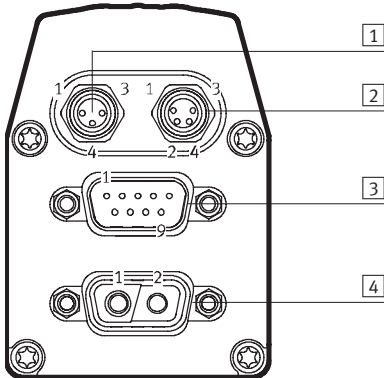

1 Reference switch, 3-pin M8 socket

Pin	Function
1	24 V
4	Reference input
3	0 V
–	

2 RS 232 interface, 4-pin M8 socket

Pin	Function
1	0 V
2	Transmitted data (TxD)
3	Received data (RxD)
4	–

3 I/O interface, 9-pin Sub-D plug

Pin	Function
1	Traversing record coding, bit 0
2	Traversing record coding, bit 1
3	Traversing record coding, bit 2
4	Traversing record coding, bit 3
5	Start bit
6	Enable bit
7	Ready signal output
8	MC signal output
9	0 V

3 CANopen interface, 9-pin Sub-D plug

Pin	Function
1	–
2	CAN_L
3	CAN_GND
4	–
5	CAN_SHLD
6	CAN_V–
7	CAN_H
8	–
9	CAN_V+

3 Profibus interface, 9-pin Sub-D socket

Pin	Function
1	–
2	Logic_GND
3	RxD/TxD-P
4	CNTR-P
5	DGND
6	VP
7	Logic_V (24 V DC)
8	RxD/TxD-N
9	–

3 DeviceNet interface, 9-pin Sub-D plug

Pin	Function
1	–
2	CAN_L
3	CAN_GND
4	–
5	CAN_SHLD
6	CAN_V–
7	CAN_H
8	–
9	CAN_V+

4 Power supply, 2-pin plug

Pin	Function
1	24 V DC (for MTR-DCI-32/42/52), 48 V DC (for MTR-DCI-62)
2	0 V
–	
–	
–	
–	
–	
–	
–	

Motor units MTR-DCI, intelligent servo motors

Technical data

FESTO

Dimensions

Download CAD data → www.festo.com

Size 42

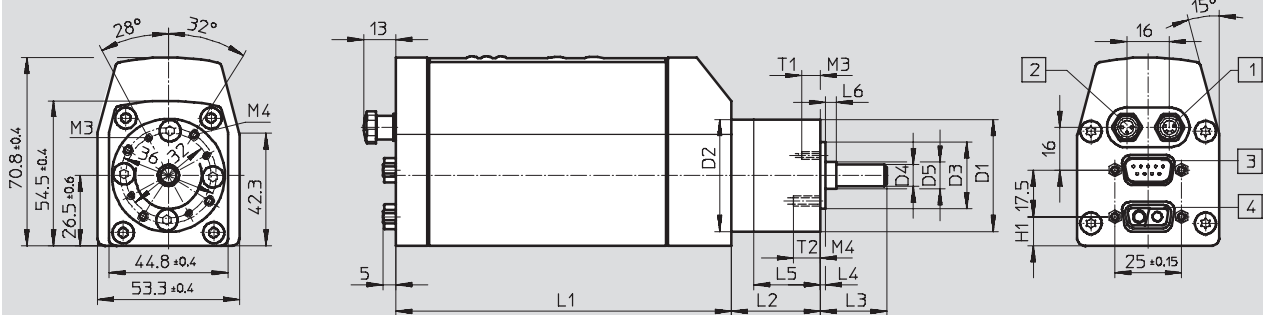

Size 32

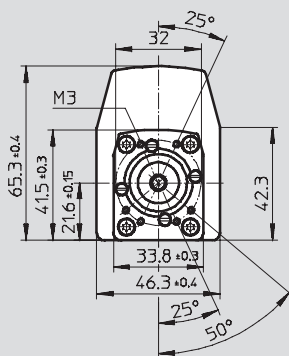

Size 52

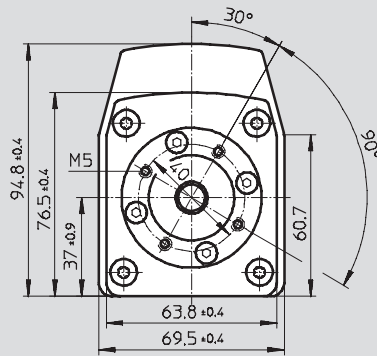

Size 62

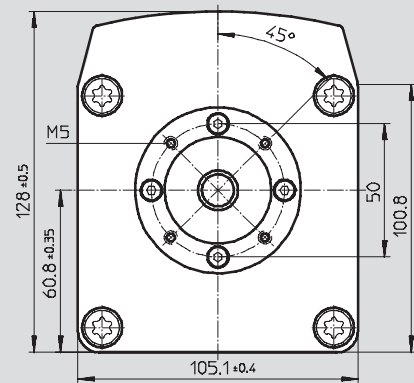

- 1 M8x1, 4-pin
- 2 M8x1, 3-pin

- 3 Sub-D, 9-pin
- 4 Sub-D, 2-pin

Type	D1	D2	D3	D4	D5	H1	L1	L2	L3	L4	L5	L6	T1	T2
	∅	∅	∅	∅	∅									
	g10	±0.1	h8	h7			±1	±1						+2
MTR-DCI-32S-...-G7	-	-	21.5	6	-	13±0.2	175.5	-	18.7±0.6	2.5±0.3	-	-	6	-
MTR-DCI-32S-...-G14	-	-	21.5	6	-	13±0.2	175.5	-	18.7±0.6	2.5±0.3	-	-	6	-
MTR-DCI-42S-...-G7	42	42	25	8	-	11	176	33.3	25±1	2±0.1	25	-	7+2	10
MTR-DCI-42S-...-G14	42	42	25	8	-	11	176	46.3	25±1	2±0.1	25	-	7+2	10
MTR-DCI-52S-...-G7	52	52	32	12	-	17.3	194	39	33±1	3±0.3	31	-	10	-
MTR-DCI-52S-...-G14	52	52	32	12	-	17.3	194	53	33±1	3±0.3	31	-	10	-
MTR-DCI-62S-...-G7	62	62	40	14	15	61.3	270	47	39±1	5±0.3	31.3	9	10	-
MTR-DCI-62S-...-G14	62	62	40	14	15	61.3	270	47	39±1	5±0.3	31.3	9	10	-
MTR-DCI-62S-...-G22	62	62	40	14	15	61.3	270	47	39±1	5±0.3	31.3	9	10	-

Motor units MTR-DCI, intelligent servo motors

Ordering data – Modular products

FESTO

M Mandatory data												
Module No.	Motor unit		Flange/size		Nominal voltage		Measuring system		Parameterisation interface			
	Motor type		Torque class		Plug design		Gearing unit		Electrical connection technology			
533 736	MTR	DCI	32	S	VC	SC	E	G7	R2	IO		
533 742			42					G14			H2	CO
533 748			52					G22			PB	
533 754			62					DN				
Order example												
533 742	MTR	- DCI	- 42	S	- VC	SC	- E	G7	- R2	IO		

Ordering table									
Size	32	42	52	62	Condi- tions	Code	Enter code		
M Module No.	533 736	533 742	533 748	533 754					
Motor unit	Motor unit						MTR	MTR	
Motor type	DC servo motor with integrated position controller						-DCI	-DCI	
Flange/size	32	42	52	62		-...			
Torque class	Standard torque class						S	S	
Nominal voltage	[V] 24 DC					-VC			
	[V] -	48 DC				-VD			
Plug design	Straight plug						SC	SC	
Measuring system	Encoder						-E	-E	
Gearing unit	Integrated planetary gearing i = 6.75						G7		
	Integrated planetary gearing i = 13.73						G14		
	-			Integrated planetary gearing i = 22.21			G22		
Parameterisation interface	RS232 interface						-R2		
	RS232 interface + control panel						-H2		
Electrical connection technology	I/O interface						IO		
	CANopen						CO		
	Profibus DP						PB		
	DeviceNet						DN		



Transfer order code

	MTR	- DCI		S		SC	- E		-		-	
--	------------	--------------	--	----------	--	-----------	------------	--	----------	--	----------	--

Motor units MTR-DCI, intelligent servo motors

Accessories

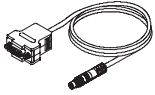

Ordering data – Cables				
	Brief description	Cable length	Part No.	Type
	Supply cable Allocation →67	2.5 m	537 931	KPWR-MC-1-SUB-9HC-2,5
		5 m	537 932	KPWR-MC-1-SUB-9HC-5
		10 m	537 933	KPWR-MC-1-SUB-9HC-10
	Control cable for I/O connection to any PLC controller Allocation →67	2.5 m	537 923	KES-MC-1-SUB-9-2,5
		5 m	537 924	KES-MC-1-SUB-9-5
		10 m	537 925	KES-MC-1-SUB-9-10
	Programming cable For parameterisation and commissioning via the RS232 interface using FCT software Allocation →67	2.5 m	537 926	KDI-MC-M8-SUB-9-2,5

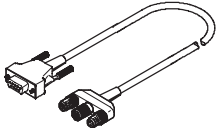
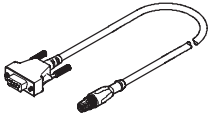
Ordering data – Plugs				
	Brief description	Part No.	Type	
Fieldbus adapter for Profibus				
	<ul style="list-style-type: none"> – 9-pin Sub-D plug to 5-pin round M12 plug/socket, plus round M12 plug for logic voltage supply – Bus terminating resistor must be connected externally 	537 934	FBA-PB-SUB-9-3XM12	
Fieldbus adapter for CANopen and DeviceNet				
	<ul style="list-style-type: none"> – 9-pin Sub-D plug to 5-pin round M12 plug – Bus terminating resistor must be connected externally 	540 324	FBA-CO-SUB-9-M12	

Motor units MTR-DCI, intelligent servo motors

Accessories



Ordering data – Software			
	Brief description	Part No.	Type
	Operator package contains: – CD-ROM – with user documentation for MTR-DCI, in the languages de, en, es, fr, it, sv – with FCT (Festo Configuration Tool) configuration software – Brief description This package is included in the scope of delivery.	550 905	PBP-MTR-DCI

Ordering data – Documentation ¹⁾							
	Language	Part No.	Type	Part No.	Type		
		For I/O interface		For Profibus interface			
	DE	539 615	P.BE-MTR-DCI-IO-DE	539 623	P.BE-MTR-DCI-PB-DE		
	EN	539 616	P.BE-MTR-DCI-IO-EN	539 624	P.BE-MTR-DCI-PB-EN		
	ES	539 617	P.BE-MTR-DCI-IO-ES	539 625	P.BE-MTR-DCI-PB-ES		
	FR	539 618	P.BE-MTR-DCI-IO-FR	539 626	P.BE-MTR-DCI-PB-FR		
	IT	539 619	P.BE-MTR-DCI-IO-IT	539 627	P.BE-MTR-DCI-PB-IT		
	SV	539 620	P.BE-MTR-DCI-IO-SV	539 628	P.BE-MTR-DCI-PB-SV		
			For CANopen interface		For DeviceNet interface		
	DE	539 629	P.BE-MTR-DCI-CO-DE	553 530	P.BE-MTR-DCI-DN-DE		
	EN	539 630	P.BE-MTR-DCI-CO-EN	553 531	P.BE-MTR-DCI-DN-EN		
	ES	539 631	P.BE-MTR-DCI-CO-ES	553 532	P.BE-MTR-DCI-DN-ES		
	FR	539 632	P.BE-MTR-DCI-CO-FR	553 533	P.BE-MTR-DCI-DN-FR		
	IT	539 633	P.BE-MTR-DCI-CO-IT	553 534	P.BE-MTR-DCI-DN-IT		
	SV	539 634	P.BE-MTR-DCI-CO-SV	553 535	P.BE-MTR-DCI-DN-SV		

1) User documentation in paper form is not included in the scope of delivery

Products and services – everything from a single source

Products incorporating new ideas are created when enthusiasm for technology and efficiency come together. Tailor-made service goes without saying when the customer is the focus of attention.

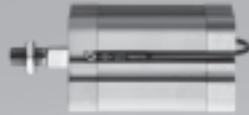

Pneumatic and electrical drives

- Pneumatic cylinders
- Semi-rotary drives
- Handling modules
- Servopneumatic positioning systems
- Electromechanical drives
- Positioning controllers and controllers



Valves and valve terminals

- Standard valves
- Universal and application-optimised valves
- Manually and mechanically actuated valves
- Shut-off, pressure control and flow control valves
- Proportional valves
- Safety valves

Fieldbus systems/ electrical peripherals

- Fieldbus Direct
- Installation system CP/CPI
- Modular electrical terminal CPX



Compressed air preparation

- Service unit combinations
- Filter regulators
- Filters
- Pressure regulators
- Lubricators
- On-off and soft-start valves
- Dryers
- Pressure amplifiers
- Accessories for compressed air preparation

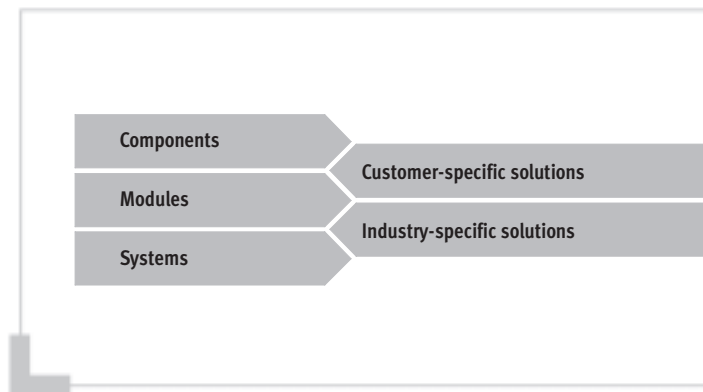

Services from Festo to increase your productivity – across the entire value creation sequence



Engineering – for greater speed in the development process

- CAD models
- 14 engineering tools
- Digital catalogue
- FluidDRAW®
- More than 1,000 technical consultants and project engineers worldwide
- Technical hotlines



Supply chain – for greater speed in the procurement process

- E-commerce and online shop
- Online order tracking
- Euro special manufacturing service
- Logistics optimisation



Gripping and vacuum technology

- Vacuum generators
- Vacuum grippers
- Vacuum security valves
- Vacuum accessories
- Standard grippers
- Micro grippers
- Precision grippers
- Heavy-duty grippers



Sensors and monitoring units

- Proximity sensors
- Pressure and flow sensors
- Display and operating units
- Inductive and optical proximity sensors
- Displacement encoders for positioning cylinders
- Optical orientation detection and quality inspection

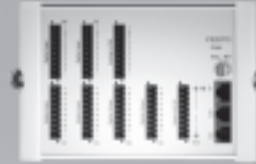

Controllers/bus systems

- Pneumatic and electropneumatic controllers
- Programmable logic controllers
- Fieldbus systems and accessories
- Timers/counters
- Software for visualisation and data acquisition
- Display and operating units



Accessories

- Pipes
- Tubing
- Pipe connectors and fittings
- Electrical connection technology
- Silencers
- Reservoirs
- Air guns

All in all, 100% product and service quality

A customer-oriented range with unlimited flexibility: Components combine to produce ready-to-install modules and systems. Included in this are special designs – since at Festo, most industry-specific products and customer-specific solutions are based on the 23,000 plus catalogue products. Combined with the services for the entire value creation sequence, the end result is unbeatable economy.



Assembly – for greater speed in the assembly/commissioning process

- Prepack
- Preassembly
- Turnkey pneumatics
- Handling solutions



Operation – for greater speed in the operational process

- Spare parts service
- Energy saving service
- Compressed air consumption analysis
- Compressed air quality analysis
- Customer service

What must be observed when using Festo components?

Specified limit values for technical data and any specific instructions must be adhered to by the user in order to ensure recommended operating conditions.

When pneumatic components are used, the user shall ensure that they are operated using correctly prepared compressed air without aggressive media.

When Festo components are used in safety-oriented applications, the user shall ensure that all applicable

national and local safety laws and regulations, for example the machine directive, together with the relevant references to standards are observed. Unauthorised conversions or modifications to products and systems from Festo involve a safety risk and are thus not permissible.

Festo does not accept any liability for resulting damages.

You should contact Festo's advisors if one of the following apply to your application:

- The ambient conditions and conditions of use or the operating medium differ from the specified technical data.
- The product is to perform a safety function.
- A risk or safety analysis is required.
- You are unsure about the product's suitability for use in the planned application.
- You are unsure about the product's suitability for use in safety-oriented applications.

All technical data applies at the time of going to print.

All texts, representations, illustrations and drawings included in this catalogue are the intellectual property of Festo AG & Co. KG, and are protected by copyright law.

All rights reserved, including translation rights. No part of this publication may be reproduced or transmitted in any form or by any means, electronic, mechanical, photocopying or otherwise, without the prior written permission of Festo AG & Co. KG. All technical data subject to change according to technical update.