

**HENGSTLER**

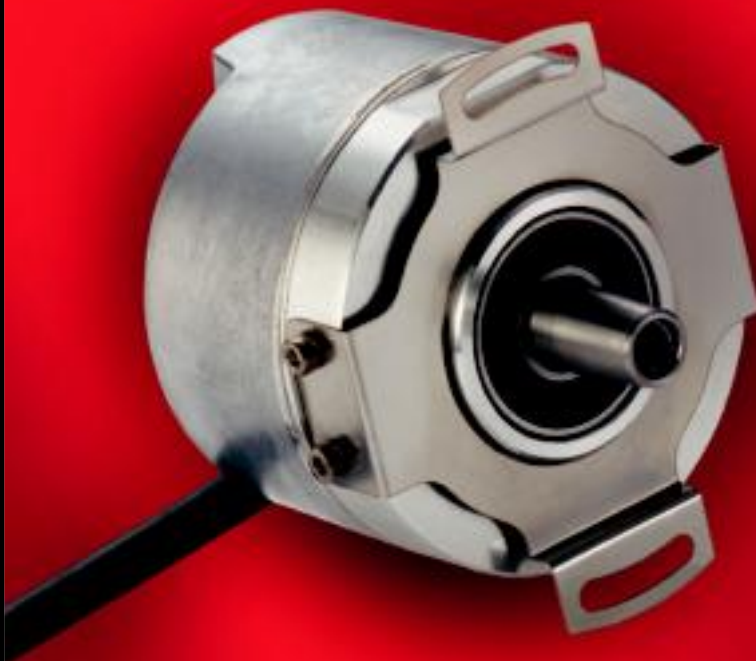

## **Encoders**

- **Incremental**
- **Absolute**
- **Motor  
Feedback  
Systems**

**Innovative products from your  
competent partner. Worldwide**

# HENGSTLER Products



## Encoders

Absolute Encoders ACURO drive and ACURO industry, Incremental Encoders, Ex-proof and stainless steel versions, Bus and Heavy Duty Encoders.



## Industrial Counting and Control Components

Starting from mini-counters up to ambitious control counters, multi-function counters, counters with interface, position indicators, timers, tachometers.



## Printers and Cutters

Printer solutions e.g. applications in the sector of info points, ticket dispensers, cash dispensers, POS systems, modular thermal and needle printers, accessories such as winders and cutters.



## Relay technology

Main focus is the worldwide most versatile product range of safety relays – relays with guided contact sets. Furthermore: bistable relays, insulation relays, high-voltage relays, mini switching relays.

## Further Danaher Brands of the Sensors & Controls Group

Dynapar™

Harowe™

Partlow™

Eagle Signal™

Namco™

Veeder-Root™

ENM™

NorthStar™

West™

# Contents

	Page
<b>GENERAL ASPECTS</b>	
■ Variety and competence - HENGSTLER today	2
■ Our service for you	4
■ HENGSTLER produces worldwide	5
<b>PRODUCTS</b>	
■ Products in this catalogue	6
■ Applications	40
<b>HEAVY DUTY ENCODERS</b>	
■ Incremental	44
■ Absolute	72
<b>STANDARD INDUSTRIAL ENCODERS INCREMENTAL</b>	
■ Solid shaft versions	85
■ Hollow shaft versions	104
<b>STANDARD INDUSTRIAL ENCODERS ABSOLUTE Single and Multiturn</b>	
■ ACURO industry BiSS/ SSI, Field bus systems, Parallel	142
<b>STAINLESS INDUSTRIAL ENCODERS</b>	
■ Incremental	199
■ Absolute	202
<b>EEX INDUSTRIAL ENCODERS</b>	
■ Incremental	236
■ Absolute	241
<b>LIGHT DUTY ENCODERS</b>	
■ Incremental	256
<b>MOTOR FEEDBACK SYSTEMS For Miniature DC &amp; Stepper Motors For Asynchronous &amp; DC Motors For AC Synchronous &amp; BLDC Motors</b>	
■ Incremental kit encoders	272
■ Hollow shaft encoders	281
■ Incremental encoders	283
■ Absolute encoders	304
■ Sine-wave encoders	317
■ Resolvers	320
<b>ACCESSORIES</b>	
■ Position indicator for absolute encoders	323
■ Encoder with shock module	326
■ Flexible couplings, Mounting elements	327
■ Connectors, cables	334
■ Measuring wheels	341
■ Displays, Technical Manuals, Software	343
<b>TECHNICAL BASICS</b>	
■ Encoders basics: Output signals incremental encoders, maximum speed, protection class, examples of flange mounting	344
■ Basics of incremental encoders - output	349
■ Basics of sine-wave encoders	354
■ Basics of absolute encoders ACURO - interfaces	356
■ Glossery of technical terms	378
<b>CONTACT &amp; OTHERS</b>	
■ Sales and Services International	384
■ Terms and Conditions	387

# Good reasons for working with Hengstler

## Better by competence.

This catalog provides proof of our competence in the business field of encoders – a comprehensive program characterized (as are all Hengstler products) by state-of-the-art technology, excellent design and highest standards of quality and reliability.

The Hengstler headquarters are located in Aldingen, in South-West Germany, on the edge of the Black Forest – a region famous for its industrial pioneers and inventors. The foundations for the Hengstler company were laid by one of these inventors, Johannes Hengstler, who, in 1846, set up a workshop which was later to become the center of the worldwide Hengstler group.

The workshop was started for the manufacture of clock springs; today, Hengstler products range from miniature counters to absolute hollow shaft encoders.



**Hengstler – you can count on us.**



The Hengstler headquarters in Aldingen.

All technical data and information contained herein, including the graphics, were collected and compiled with the utmost care.

This brochure provides information on products and accessories, which, however, does not constitute any guarantee for technical data or features. The user of these products must determine himself the suitability of the product for the intended use. All technical data is subject to alterations. For questions of technical nature or regarding prices and delivery, please contact our company headquarters or field service employees.

# Successful with Hengstler



## Innovation at an international level

Our numerous branches and representatives in Europe, America and Asia have made us a truly international enterprise. Our availability around the globe is, of course, a great benefit for our customers – the next Hengstler contact is never far away.

Our sound footing in all parts of the world also has a positive effect on our product know-how. Findings from worldwide research programs provide a pool of information from which, in turn, the material for the carefully directed, overall technological concept is won. These findings form the practice-oriented basis for ongoing innovation and efficiency in all corporate sectors.

The pace of innovation is getting faster and faster in all sectors of technology. Only those who are able to follow or even set this pace will continue to be competitive. Strong, reliable partners are needed to help you cope with these new demands. You need partners whose top priority is added product value/customer value, customer-orientation and high quality.

And taking all this into account, Hengstler is your partner of choice.

Hengstler is a leading European manufacturer in the field of industrial counting and control components, e.g. counters, encoders and relays. The product range is complemented by printers and cutters, with Hengstler being the leading manufacturer for cutters in Europe.

## Hengstler: Your Technology Partner

One of our particular strengths is the project management of custom applications. The basis for this is our wide experience gained over many years in the fields of electromechanics, mechanics, pneumatics and electronics which is, of course, mirrored in our product program. Hengstler offers its customers complete support starting at the project planning and development right through to the final product. At present we are handling complex projects in the field of pneumatics and printers for well-known companies, such as Bosch, Festo, IBM and Siemens.

**Talk to Hengstler.**  
**We can offer solutions.**

## Customer Orientation

- Hengstler is never far away – wherever you are in the world
- Application-specific assistance
- Customer-oriented manufacturing (one-piece-flow)
- Fair price/performance ratio
- Short delivery times and a high degree of availability
- 48-hour repair service

## Experience

Hengstler was founded in 1846 and has been manufacturing counters since 1926, printers since 1970, encoders since 1987, relays since 1983...

## Quality

- High-quality materials in accordance with VDE (Association of German Electrotechnical Engineers)
- UL, CL- and TÜV approvals
- TÜV-certified to ISO 9001:2000
- Environmental certified to DIN ISO 14001

## Competence

- Vast know-how in the fields of development and manufacturing.
- Assistance and support are provided by specialists.

## Variety

- Hengstler offers a wide range of components for counting, controlling, indicating, measuring, switching and printing
- Get it all from one source!
- Benefit from numerous variants – for added flexibility.

## Innovation

- Product development is based on state-of-the-art technology and highly advanced processes.
- Our products are setting the pace - around the globe
- We offer communicative products with state-of-the-art bus technology.

# Our service for you



## Customer Service

– always remains close to you – thanks to our extensive sales & distribution network. Please contact your local Hengstler distributor, addresses see chapter “Contact” (page 384).

**Talk to Hengstler.**  
We offer solutions.

## Customer Advantages:

- Personal customer service
- Many years of experience

## World-wide Representation

You will always find a friendly contact at Hengstler – wherever you are in the world. Our experienced, competent partners are familiar with your branch – just get in touch. Please contact your local Hengstler distributor, addresses see chapter “Contact” (page 384).

## Customer Advantages:

- We’re there for you – wherever you are – worldwide

## Technical Support

If you should have any technical questions concerning your product selection or specific application – get fast and competent help. See chapter “Contact” (page 384).

## Customer Advantages:

- Quick response to your technical queries

## Always on the safe side

Quality and reliability of our products are our top priority. Our quality management system is TÜV-certified to DIN EN ISO 9001:2000 Reg.No. 12 100/104 32249 TMS.

## Environmental responsibility

We are committed to environmentally responsible business practices and production. This is why our company has been certified to the DIN ISO 14001: 2004 environmental management systems standard.

## Order Service

You can reach our team to place your order by phone between 8.00 am and 4.30 pm:

**Phone +49 800-436 47 85 37 or  
Phone +49 7424-89 201**

Orders may also be placed 24 hours by  
**Fax +49 7424-89 500**

## Customer Advantages:

- No minimum order quantities or extra charge for small order sizes
- At any time reachable for your orders

Your order will be processed immediately after receipt. If any question remains regarding your order, we will call you back.

Please contact us if you require a quotation for higher quantities, special versions or delivery times. If you can’t find your desired product in our catalogue, don’t hesitate to let us know - we would be glad to help you.

Please visit also our website at  
[www.hengstler.com](http://www.hengstler.com)

# HENGSTLER produces worldwide

**Germany – HENGSTLER GmbH**  
Aldingen



**Slovakia – HENGSTLER sro**  
Kezmarok



**USA – Danaher Controls**  
Gurnee, Illinois

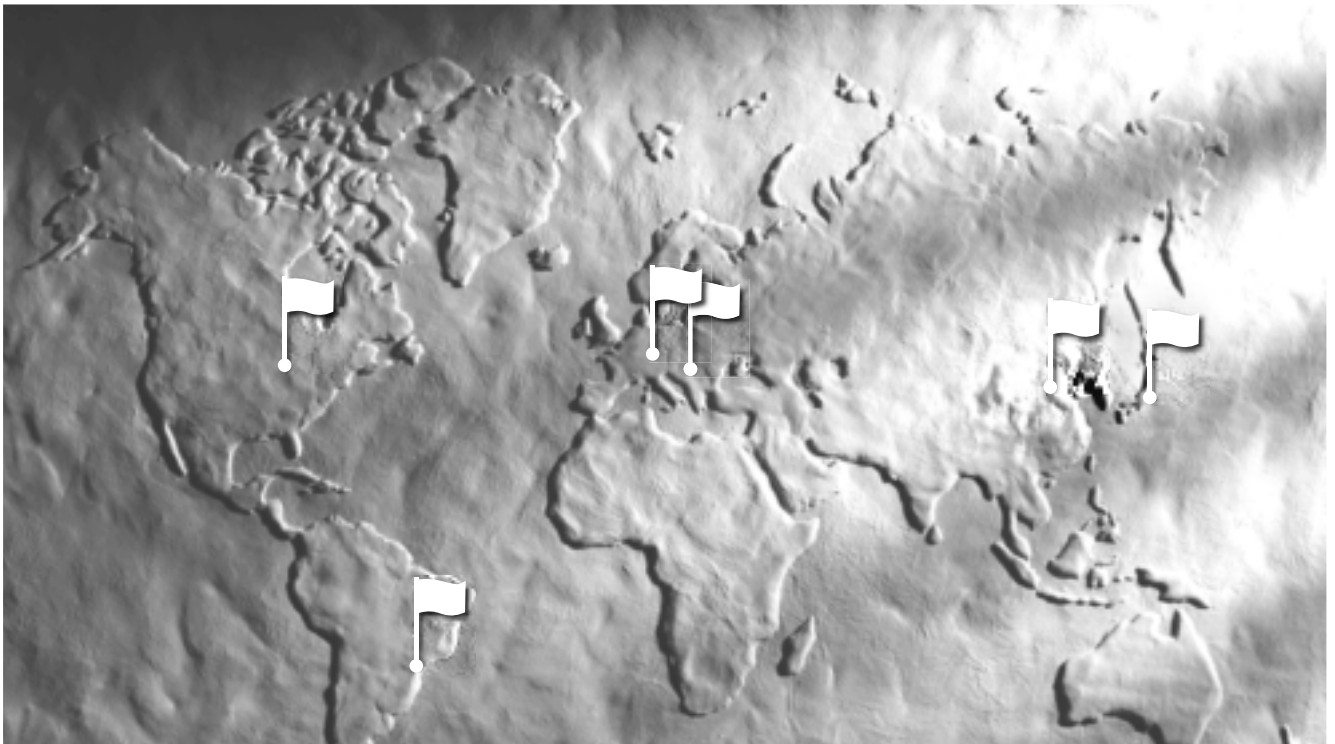

**Brasil – Veeder Root do Brasil**  
Sao Paulo



**China – Danaher ICG China**  
Tianjin



**Japan – Danaher ICG Japan Co.**  
Osaka

# Heavy Duty Types - Incremental

NorthStar™

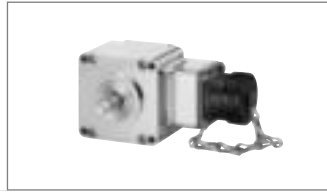

Type	HD 20	HD 25	HSD 25
<b>Special features</b>	<ul style="list-style-type: none"> <li>■ Single or Dual output</li> <li>■ ATEX Certification available for Intrinsically Safe application</li> <li>■ High Resolution Unbreakable Disk</li> <li>■ Industrial Duty Connector</li> <li>■ NEMA 4X / IP67 Rated</li> <li>■ Nickel or Stainless Steel Housing available</li> </ul>	<ul style="list-style-type: none"> <li>■ Single or Dual output</li> <li>■ Optional high current line driver</li> <li>■ ATEX Certification available for Intrinsically Safe application</li> <li>■ High Resolution Unbreakable Disk</li> <li>■ Industrial Duty Connector</li> <li>■ NEMA 4X / IP67 Rated</li> <li>■ Nickel or Stainless Steel Housing available</li> </ul>	<ul style="list-style-type: none"> <li>■ Single or Dual output</li> <li>■ ATEX Certification available for Intrinsically Safe application</li> <li>■ High Resolution Unbreakable Disk</li> <li>■ Industrial Duty Connector</li> <li>■ NEMA 4X, 6 / IP66, 67 Rated</li> <li>■ Nickel or Stainless Steel Housing available</li> </ul>
<b>Technical Data - mechanical</b>			
Housing diameter	52.3 mm	67.3 mm	58.93 mm
Shaft diameter	9.52 mm ... 10 mm (Solid shaft)	9.52 mm ... 10 mm (Solid shaft)	9.52 mm ... 19.05 mm (Hubshaft)
Flange (Mounting of housing)	Square flange	Square flange	Tether
Protection class shaft input	NEMA 4X or IP67	NEMA 4X or IP67	NEMA 4X or NEMA 6 IP66 or IP67
Protection class housing	NEMA 4X or IP67	NEMA 4X or IP67	NEMA 4X or NEMA 6 IP66 or IP67
Shaft load axial / radial	max.: 440 N / 440 N	max.: 440 N / 440 N	
Max. speed	max. 6000 rpm	max. 6000 rpm	
Vibration resistance	200 m/s <sup>2</sup> (5 ... 2000 Hz)	200 m/s <sup>2</sup> (5 ... 2000 Hz)	200 m/s <sup>2</sup> (5 ... 2000 Hz)
Shock resistance	500 m/s <sup>2</sup> (11 ms)	500 m/s <sup>2</sup> (11 msec)	500 m/s <sup>2</sup> (11 sec)
Operating temperature	-40 °C ... +100 °C ATEX: -40 °C ... +80 °C	-40 °C ... +100 °C ATEX: -40 °C ... +80 °C	-40 °C ... +100 °C ATEX: -40 °C ... +80 °C
Connection	MS / M12	MS / M12	MS / M12
<b>Technical Data - electrical</b>			
Supply voltage	DC 5 - 26 V		
Max. current w/o load	max. 50 mA	max. 50 mA	max. 50 mA
Max. pulse frequency	125 kHz	125 kHz	125 kHz
Output	RS422 / Push-Pull / NPN-O.C.	RS422 / Push-Pull / NPN-O.C.	RS422 / Push-Pull / NPN-O.C.
Pulse shape	Square wave	Square wave	Square wave
Page	44	48	52



# Heavy Duty Types - Incremental

NorthStar™

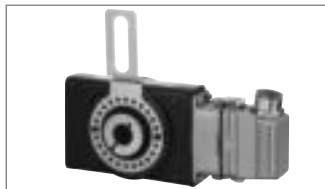

Products

Type	HSD 35	HSD 37	HSD 38
<b>Special features</b>	<ul style="list-style-type: none"> <li>■ Hollow Shaft design eliminates mounting bracket, flexible shaft coupling, and installation labor</li> <li>■ Bore is electrically and thermally insulated</li> <li>■ Single or Dual output - Optional high current line driver</li> <li>■ Choice of Stamped Metal or Swivel Rod Tether</li> <li>■ High Resolution Unbreakable Disk</li> <li>■ Industrial Duty Latching Connector</li> <li>■ NEMA 4 / IP65 Rated</li> </ul>	<ul style="list-style-type: none"> <li>■ Single or Dual Output</li> <li>■ Double-Sealed Housing</li> <li>■ ATEX Certification for Intrinsically Safe Applications</li> <li>■ High Resolution Unbreakable Disk</li> <li>■ Electrically and Thermally Isolated</li> <li>■ Industrial Duty Connector</li> <li>■ NEMA 4X, 6 / IP66, 67 Rated</li> <li>■ Rugged Cast-Aluminum Housing</li> <li>■ Stainless Steel Housing Available</li> </ul>	<ul style="list-style-type: none"> <li>■ Double-Sealed Housing</li> <li>■ High Resolution Unbreakable Disk</li> <li>■ Electrically and Thermally Isolated</li> <li>■ Industrial Duty Connector</li> <li>■ NEMA 4X, 6 / IP66 or IP67 Rated</li> <li>■ Rugged Cast-Aluminum Housing</li> </ul>
<b>Technical Data - mechanical</b>			
Housing diameter	90.2 mm	95.25 mm	96.52 mm
Shaft diameter	6 mm ... 31.75 mm (Through hollow shaft)	12 mm ... 22.2 mm (Through hollow shaft)	12 mm ... 22.2 mm (Hubshaft)
Flange (Mounting of housing)	Tether, Swivel rod	Tether	Tether
Protection class shaft input	IP65 or NEMA 4	NEMA 4X or NEMA 6 IP66 or IP67	NEMA 4X or NEMA 6 IP66 or IP67
Protection class housing	IP65 or NEMA 4	NEMA 4X or NEMA 6 IP66 or IP67	NEMA 4X or NEMA 6 IP66 or IP67
Max. speed	max. 3600 rpm		
Vibration resistance	200 m/s <sup>2</sup> (5 ... 2000 Hz)	200 m/s <sup>2</sup> (5 ... 2000 Hz)	200 m/s <sup>2</sup> (5 ... 2000 Hz)
Shock resistance	500 m/s <sup>2</sup> (11 ms)	500 m/s <sup>2</sup> (11 msec)	500 m/s <sup>2</sup> (11 msec)
Operating temperature	-40 °C ... +70 °C Option: 0 °C ... +100 °C	-40 °C ... +100 °C ATEX: -40 °C ... +80 °C	-40 °C ... +100 °C
Connection	10 pin connector	MS / M12	MS / M12
<b>Technical Data - electrical</b>			
Supply voltage			DC 5 - 26 V
Max. current w/o load	max. 100 mA	max. 50 mA	max. 50 mA
Max. pulse frequency	100 kHz	125 kHz	125 kHz
Output	Push-Pull / RS422 / RS422	RS422 / Push-Pull / NPN-O.C.	RS422 / Push-Pull / NPN-O.C.
Pulse shape	Square wave	Square wave	Square wave
Page	56	60	64

# Heavy Duty Types - Incremental

**NorthStar**



Type	DWD 38
<b>Special features</b>	<ul style="list-style-type: none"> <li>■ Single or Dual output - NAMUR available</li> <li>■ Well suited for DrawWorks/ oil field application</li> <li>■ ATEX Certification available for Intrinsically Safe application</li> <li>■ High Resolution Unbreakable Disk</li> <li>■ Industrial Duty Connector</li> <li>■ NEMA 4X / IP67 Rated</li> <li>■ Nickel or Stainless Steel Housing available</li> <li>■ Option: removable shaft with thread</li> <li>■ Option: redundant output</li> </ul>
<b>Technical Data - mechanical</b>	
Housing diameter	3.75"
Flange (Mounting of housing)	Synchro flange
Protection class shaft input	IP67 or NEMA 6
Protection class housing	IP67 or NEMA 6
Shaft load axial / radial	Max.: 100 N / 100 N
Vibration resistance	200 m/s <sup>2</sup> (5 to 2000 Hz)
Shock resistance	500 m/s <sup>2</sup> (11 msec)
Operating temperature	-40 °C ... +100 °C ATEX: -40 °C ... +80 °C
Connection	MS
<b>Technical Data - electrical</b>	
Supply voltage	DC 5 - 26 V
Max. current w/o load	max. 50 mA
Max. pulse frequency	125 kHz
Output	RS422 / NPN-O.C. / Push-Pull / NAMUR
Page	68

## Heavy Duty Types - Absolute

ACURO®-XR HENGSTLER

SSI

SSI

CANopen

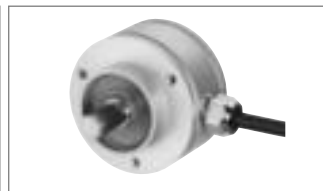
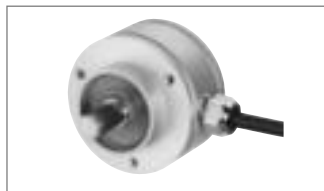
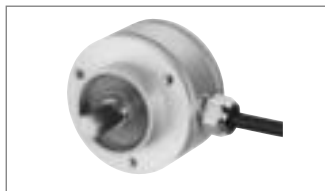

Type	AR 62/63 - BiSS/SSI	AR 62/63 - CANopen	AR 62/63 - Analogue
<b>Special features</b>	<ul style="list-style-type: none"> <li>■ Singleturn 12 Bit Resolution</li> <li>■ 300 N axial and radial load</li> <li>■ 200 g shock resistance</li> <li>■ 20 g vibrations resistance</li> <li>■ Submersible: Protection class up to IP69k</li> <li>■ High temperature range: -40 ... +100°C</li> <li>■ Compact design: 32 mm mounting depth</li> <li>■ Option: Stainless steel housing</li> <li>■ Option: Control inputs Preset and Direction</li> </ul>	<ul style="list-style-type: none"> <li>■ Singleturn 12 Bit Resolution</li> <li>■ 300 N axial and radial load</li> <li>■ 200 g shock resistance</li> <li>■ 20 g vibration resistance</li> <li>■ Submersible: Protection class up to IP69K</li> <li>■ High temperature range: -40 ... +100°C</li> <li>■ Compact design: 32 mm mounting depth</li> <li>■ Option: Stainless steel housing</li> </ul>	<ul style="list-style-type: none"> <li>■ Singleturn 12 Bit Resolution</li> <li>■ 300 N axial and radial load</li> <li>■ 200 g shock resistance</li> <li>■ 20 g vibration resistance</li> <li>■ Submersible: Protection class up to IP69k</li> <li>■ High temperature range: -40 ... +100°C</li> <li>■ Compact design: 32 mm mounting depth</li> <li>■ Option: Stainless steel housing</li> <li>■ Option: Control inputs Preset and Direction</li> </ul>
<b>Technical Data - mechanical</b>			
Housing diameter	58 mm	58 mm	58 mm
Mounting depth	32 mm	32 mm	32 mm
Shaft diameter			
Flange (Mounting of housing)	Synchro clamping flange	Synchro clamping flange	Synchro clamping flange
Protection class shaft input	IP67 or IP69k	IP67 or IP69k	IP67 or IP69k
Protection class housing	IP67 or IP69k	IP67 or IP69k	IP67 or IP69k
Shaft load axial / radial	max.: 300 N / 300 N	max.: 300 N / 300 N	max.: 300 N / 300 N
Max. speed	max. 5000 rpm	max. 5000 rpm	max. 5000 rpm
Vibration resistance	200 m/s <sup>2</sup>	200 m/s <sup>2</sup>	200 m/s <sup>2</sup>
Shock resistance	2000 m/s <sup>2</sup> (6 ms)	2000 m/s <sup>2</sup> (6 ms)	2000 m/s <sup>2</sup> (6 ms)
Operating temperature	-40 °C ... +100 °C	-40 °C ... +100 °C	-40 °C ... +100 °C
Connection	Cable / M12	Cable / M12	Cable / M12
<b>Technical Data - electrical</b>			
Supply voltage	DC 10-30 V	DC 10-30 V	DC 17 - 30 V
Max. current w/o load	max. 50 mA	max. 220 mA	max. 50 mA
EMC	EN 61326 Class A	EN 61326 Class A	EN 61326 Class A
Resolution singleturn	12 Bit	12 Bit	12 Bit
Interface			Analogue: 0 ... 10 V, Analogue: 4 ... 20 mA
Output code	Gray	Binary	
Interface		CAN High-Speed according to ISO/DIS 11898	
Profile/ protocol		CANopen according to DS 301 with profile DSP 406, programmable encoder according class C2	
Parametrization		Scaling, Preset, Offset, Direction	
Integrated special functions		Speed, Acceleration, Limit values	
Control inputs	Preset, Direction		Direction, Preset
Page	72	76	80

## Standard Industrial Types - Incremental

### Solid Shaft



Type	RI 30	RI 36-0	RI 58-0 / RI 58-T
<b>Special features</b>	<ul style="list-style-type: none"> <li>■ Miniature encoder for industrial use</li> <li>■ Low current consumption</li> <li>■ High noise interference immunity</li> <li>■ Cable lengths of up to 100 m</li> <li>■ Suitable for high pulse frequencies</li> <li>■ High protection class</li> <li>■ Applications: CNC machines, manipulators, motors, medical technology, textile machines</li> </ul>	<ul style="list-style-type: none"> <li>■ Miniature industry standard encoder for high numbers of pulses</li> <li>■ High reliability</li> <li>■ Applications: CNC axles, machine tools, robots, special purpose machines, high-speed winding machines</li> </ul>	<ul style="list-style-type: none"> <li>■ Universal industry standard encoder</li> <li>■ Up to 40 000 steps with 10 000 pulses</li> <li>■ High signal accuracy</li> <li>■ Protection class up to IP67</li> <li>■ Flexible due to many flange and configuration variants</li> <li>■ Suitable for high shock ratings</li> <li>■ Applications: machine tools, CNC axles, packing machines, motors/ drives, injection moulding machines, sawing machines, textile machines</li> <li>■ For EX version, see RX 70-I</li> <li>■ Operating temperature up to 100 °C (RI 58-T)</li> </ul>
Number of pulses	5 ... 1500	5 ... 3600	1 ... 10 000
<b>Technical Data - mechanical</b>			
Housing diameter	30 mm	36 mm	58 mm
Shaft diameter	5 mm (Solid shaft)	6 mm ... 6.35 mm (Solid shaft)	6 mm ... 12 mm (Solid shaft)
Flange (Mounting of housing)	Synchro flange, Pilot flange	Synchro flange, Pilot flange	Synchro flange, Clamping flange, Square flange, Synchro clamping flange
Protection class shaft input	IP64	IP64	IP64 or IP67
Protection class housing	IP64	IP64	IP65 or IP67
Shaft load axial / radial	5 N / 10 N	5 N / 10 N	Ø 6 mm / 6,35 mm: 20 N / 40 N Ø 7 ... 10 mm: 40 N / 60 N Ø 12 mm: 60 N / 80 N
Max. speed	max. 10 000 rpm	max. 10 000 rpm	max. 10 000 rpm
Vibration resistance	100 m/s <sup>2</sup> (10 ... 2000 Hz)	100 m/s <sup>2</sup> (10 ... 2000 Hz)	100 m/s <sup>2</sup> (10 ... 2000 Hz)
Shock resistance	1000 m/s <sup>2</sup> (6 ms)	1000 m/s <sup>2</sup> (6 ms)	1000 m/s <sup>2</sup> (6 ms)
Operating temperature	-10 °C ... +70 °C	-10 °C ... +70 °C	RI 58-0: -10 °C ... +70 °C RI 58-T: -25 °C ... +100 °C
Connection	Cable / M16	Cable / M16	cable / M23 / M16 / MS
<b>Technical Data - electrical</b>			
Supply voltage	DC 5 V / DC 10-30 V	DC 5 V / DC 10-30 V	DC 5 V / DC 10-30 V
Max. current w/o load	max. 30 mA	max. 30 mA	max. 30 mA
Max. pulse frequency	RS422: 300 kHz Push-pull: 200 kHz	RS422: 300 kHz Push-pull: 200 kHz	RS422: 300 kHz Push-pull: 200 kHz
Output	RS422 / Push-Pull	RS422 / Push-Pull / Push-pull complementary	RS422 / Push-Pull / Push-pull complementary
Alarm output	NPN-O.C., max. 5 mA	NPN-O.C., max. 5 mA	NPN-O.C., max. 5 mA
Pulse shape	Square wave	Square wave	Square wave
Page	85	90	94

## Standard Industrial Types - Incremental Hollow Shaft



Type	RI 36-H	RI 58-H	RI 58-D / RI 58TD
<b>Special features</b>	<ul style="list-style-type: none"> <li>■ Miniature industry encoder for high number of pulses</li> <li>■ Short mounting length</li> <li>■ Easy mounting procedure</li> <li>■ Applications: motors, machine tools, robots, automated SMD equipment</li> </ul>	<ul style="list-style-type: none"> <li>■ Through hollow shaft</li> <li>■ High accuracy by means of integrated flexible coupling</li> <li>■ Safe shaft mounting</li> <li>■ Applications: textile machines, motors, drives, copiers</li> </ul>	<ul style="list-style-type: none"> <li>■ Direct mounting without coupling</li> <li>■ Flexible hollow shaft design up to diameter 14 mm</li> <li>■ Through hollow shaft or as end shaft (blind shaft)</li> <li>■ Easy installation by means of clamping shaft or blind shaft</li> <li>■ Short overall length of 33 mm</li> <li>■ Fixing of flange by means of a stator coupling or set screw</li> <li>■ Various shaft versions</li> <li>■ Applications: actuators, motors</li> <li>■ Operating temperature up to 100 °C (RI 58TD)</li> </ul>
Number of pulses	5 ... 3600	1 ... 5000	1 ... 5000
<b>Technical Data - mechanical</b>			
Housing diameter	36 mm	58 mm	58 mm
Shaft diameter	4 mm ... 10 mm (Hubshaft)	10 mm ... 12 mm (Hubshaft)	10 mm ... 12 mm (Through hollow shaft) 10 mm ... 14 mm (Hubshaft)
Flange (Mounting of housing)	Tether	Synchro flange	Synchro flange
Protection class shaft input	IP64	IP64	IP64
Protection class housing	IP64	IP64	Through hollow shaft - D: IP64 Hubshaft - E,F: IP65
Max. speed	max. 10 000 rpm	max. 3000 rpm	max. 4000 rpm
Vibration resistance	100 m/s <sup>2</sup> (10 ... 2000 Hz)	10 g = 100 m/s <sup>2</sup> (10 ... 2000 Hz)	10 g = 100 m/s <sup>2</sup> (10 ... 2000 Hz)
Shock resistance	1000 m/s <sup>2</sup> (6 ms)	100 g = 1000 m/s <sup>2</sup> (6 ms)	100 g = 1000 m/s <sup>2</sup> (6 ms)
Operating temperature	-10 °C ... +70 °C	-10 °C ... +70 °C	RI 58-D: -10 °C ... +70 °C RI 58TD: -25 °C ... +100 °C
Connection	Cable	Cable	Cable / M23
<b>Technical Data - electrical</b>			
Supply voltage	DC 5 V / DC 10-30 V	DC 5 V / DC 10-30 V	DC 5 V / DC 10-30 V
Max. current w/o load	max. 30 mA	max. 30 mA	max. 30 mA
Max. pulse frequency	RS422: 300 kHz Push-pull: 200 kHz	RS422: 300 kHz Push-pull: 200 kHz	RS422: 300 kHz Push-pull: 200 kHz
Output	RS422 / Push-Pull / Push-pull complementary	RS422 / Push-Pull / Push-pull complementary	RS422 / Push-Pull / Push-pull complementary
Alarm output	NPN-O.C., max. 5 mA		NPN-O.C., max. 5 mA
Pulse shape	Square wave	Square wave	Square wave
Page	104	109	113

# Standard Industrial Types - Incremental Hollow Shaft



Type	RI 58-G / RI 58TG	RI 58-F
<b>Special features</b>	<ul style="list-style-type: none"> <li>■ Direct mounting without coupling</li> <li>■ Through hollow shaft Ø 14 mm and 15 mm</li> <li>■ Easy installation by means of clamping ring</li> <li>■ Fixing of flange by means of a stator coupling or set screw</li> <li>■ Applications: actuators, motors</li> </ul>	<ul style="list-style-type: none"> <li>■ Incremental hollow shaft encoder</li> <li>■ Up to 10000 ppr</li> <li>■ Through hollow shaft and hubshaft up to 12 mm (14 mm optional)</li> <li>■ Optimized stator coupling</li> <li>■ Applications: Feedback for asynchronous motors, industrial applications</li> </ul>
Number of pulses	50 ... 2500	1 ... 10 000
<b>Technical Data - mechanical</b>		
Housing diameter	58 mm	58 mm
Shaft diameter	14 mm ... 15 mm (Through hollow shaft)	6 mm ... 12 mm (Hubshaft) 6 mm ... 12 mm (Through hollow shaft)
Flange (Mounting of housing)	Synchro flange	Tether
Protection class shaft input	IP64	IP64
Protection class housing	IP64	Through hollow shaft - D: IP64 Hubshaft - F: IP67
Max. speed	max. 4000 rpm	max. 6000 rpm
Vibration resistance	10 g = 100 m/s <sup>2</sup> (10 ... 2000 Hz)	100 m/s <sup>2</sup>
Shock resistance	100 g = 1000 m/s <sup>2</sup> (6 ms)	1000 m/s <sup>2</sup>
Operating temperature	RI 58-G: -10 °C ... +70 °C RI 58TG: -10 °C ... +100 °C	-10 °C ... +70 °C
Connection	Cable	Cable / M23
<b>Technical Data - electrical</b>		
Supply voltage	DC 5 V / DC 10-30 V	DC 5 V / DC 10-30 V
Max. current w/o load	max. 30 mA	max. 30 mA
Max. pulse frequency	RS422: 300 kHz Push-pull: 200 kHz	
Output	RS422 / Push-Pull / Push-pull complementary	RS422 / Push-Pull / Push-pull complementary
Alarm output	NPN-O.C., max. 5 mA	
Pulse shape	Square wave	
Page	122	128

## Standard Industrial Types - Incremental Hollow Shaft

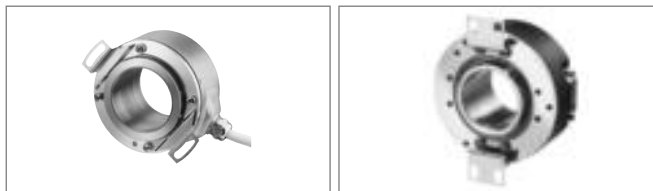

Type	RI 76TD	RI 80-E
<b>Special features</b>	<ul style="list-style-type: none"> <li>■ Through hollow shaft Ø 15 bis 42 mm</li> <li>■ Outside diameter only 76 mm</li> <li>■ Easy installation by means of clamping ring front or rear</li> <li>■ Operating temperature up to 100 °C</li> <li>■ Applications: motors, printing machines, lifts</li> </ul>	<ul style="list-style-type: none"> <li>■ Incremental</li> <li>■ 30 - 45 mm hollow shaft</li> <li>■ Rugged mechanical design</li> <li>■ Unbreakable disc</li> <li>■ Integrated diagnostic system</li> <li>■ Wide voltage range DC 5 - 30 V</li> <li>■ Isolated shaft</li> </ul>
Number of pulses	1 ... 10 000	1024, 2048, 2500, 4096, 5000, 10 000 (other number of pulses on request)
<b>Technical Data - mechanical</b>		
Housing diameter	76 mm	100 mm
Shaft diameter	15 mm ... 40 mm (Hub shaft)	10 mm ... 12 mm (Through hollow shaft)
Flange (Mounting of housing)	Tether	Tether
Protection class shaft input	IP40 or IP64	IP50 or IP64
Protection class housing	IP50 (IP65 optional)	IP50 or IP64
Max. speed	max. 1800 rpm	max. 1500 rpm
Vibration resistance	10 g = 100 m/s <sup>2</sup> (10 ... 2000 Hz)	
Shock resistance	100 g = 1000 m/s <sup>2</sup> (6 ms)	
Operating temperature	-25 °C ... +100 °C	-25 °C ... +85 °C
Connection	Cable	Sub-D
<b>Technical Data - electrical</b>		
Supply voltage	DC 5 V / DC 10-30 V	DC 5 V ±10 % / DC 5-30 V
Max. current w/o load	max. 35 mA	max. 35 mA
Max. pulse frequency	RS422: 300 kHz Push-pull: 200 kHz	RS422: 600 kHz Push-pull: 200 kHz
Output	RS422 / Push-Pull / Push-pull complementary	RS422 / Push-Pull / Push-pull complementary
Alarm output	NPN-O.C., max. 5 mA	NPN-O.C., max. 5 mA
Pulse shape	Square wave	Square wave
Page	132	136

## Standard Industrial Types - Absolute

### AC 36 - BiSS / SSI



- Compact design for single or multiturn
- Interfaces: standard SSI, expanded SSI mode or BiSS
- Use of sine / cosine signals for fast control tasks possible



Type	AC 36 - BiSS / SSI
<b>Technical Data - mechanical</b>	
Housing diameter	37.5 mm
Shaft diameter	6 mm (Solid shaft)
Flange (Mounting of housing)	Pilot flange
Protection class shaft input	IP64
Protection class housing	IP64
Max. speed	max. 12 000 rpm
Vibration resistance	100 m/s <sup>2</sup> (10 ... 2000 Hz)
Shock resistance	1000 m/s <sup>2</sup> (6 ms)
Operating temperature	-25 °C ... +100 °C
Connection	Cable
<b>Technical Data - electrical</b>	
Supply voltage	-5% / 10% DC 5 V / DC 7-30 V
Max. current w/o load	max. 100 mA
Resolution singleturn	12 -17 Bit
Resolution multiturn	12 Bit
Output code	Gray, Binary
Alarm output	Alarm bit (SSI Option), warning and alarm bit (BiSS)
Page	142



## Standard Industrial Types - Absolute

### AC 58 - BiSS / SSI, Parallel



- Compact design for single or multiturn
- Aids for start-up and operation: diagnostic LED, preset key with optical response
- Interfaces: standard SSI, expanded SSI mode or BiSS
- Use of sine / cosine signals for fast control tasks possible



Type	AC 58 - BiSS / SSI	AC 58 - Parallel
<b>Technical Data - mechanical</b>		
Housing diameter	58 mm	58 mm
Shaft diameter	6 mm ... 10 mm (Solid shaft) 10 mm ... 12 mm (Hub shaft)	6 mm ... 10 mm (Solid shaft) 10 mm ... 12 mm (Hub shaft)
Flange (Mounting of housing)	Synchro flange, Clamping flange, Tether, Square flange	Synchro flange, Clamping flange, Tether, Square flange
Protection class shaft input	IP64 or IP67	IP64 or IP67
Protection class housing	IP64 or IP67	IP64 or IP67
Shaft load axial / radial	40 N / 60 N	40 N / 60 N
Max. speed	max. 12 000 rpm	max. 12 000 rpm
Vibration resistance	100 m/s <sup>2</sup> (10 ... 2000 Hz)	100 m/s <sup>2</sup> (10 ... 2000 Hz)
Shock resistance	1000 m/s <sup>2</sup> (6 ms)	1000 m/s <sup>2</sup> (6 ms)
Operating temperature	-40 °C ... +100 °C	-40 °C ... +100 °C
Connection	Cable / M23 / M12	Cable / M23 / Sub-D
<b>Technical Data - electrical</b>		
Supply voltage	-5% / 10% DC 5 V / DC 10-30 V	DC 10-30 V
Max. current w/o load	max. 100 mA	max. 300 mA
Resolution singleturn	10 - 17 Bit Gray Excess: 360, 720 increments	10 - 14 Bit Gray Excess: 360, 720 increments
Resolution multiturn	12 Bit	12 Bit
Output code	Binary, Gray	Binary, Gray, Gray Excess
Parametrization	Code type, Direction, Warning, Alarm	
Output current		30 mA per Bit, short-circuit-proof
Control inputs	Direction	Latch, Direction, Tristate with ST, Tristate with MT
Reset key	Disable via parameterization	
Alarm output	Alarm bit (SSI Option), warning and alarm bit (BiSS)	NPN-O.C., max. 5 mA
Status LED	Green = ok, red = alarm	Green = ok, red = alarm
Page	147	153

# Standard Industrial Types - Absolute

## AC 58 with Fieldbus Interfaces



- Overall length: 63 mm for singleturn, 73 mm for multiturn, including bus cover
- The complete bus specific electronics is integrated in the bus cover
- Option: Display "tico"
- Diagnostic LEDs in the bus cover



Type	AC 58 - Profibus	AC 58 - CANopen	AC 58 - CANlayer2
<b>Technical Data - mechanical</b>			
Housing diameter	58 mm	58 mm	58 mm
Shaft diameter	6 mm ... 10 mm (Solid shaft) 10 mm ... 12 mm (Hub shaft)	6 mm ... 10 mm (Solid shaft) 10 mm ... 12 mm (Hub shaft)	6 mm ... 10 mm (Solid shaft) 10 mm ... 12 mm (Hub shaft)
Flange (Mounting of housing)	Synchro flange, Clamping flange, Tether, Square flange	Synchro flange, Clamping flange, Tether, Square flange	Synchro flange, Clamping flange, Tether, Square flange
Protection class shaft input	IP64 or IP67	IP64 or IP67	IP64 or IP67
Protection class housing	IP67	Connection bus cover: IP67 Connection cable or M23 (conin): IP64 (IP67 optional)	IP67 or IP64 (IP67 optional)
Shaft load axial / radial	40 N / 60 N	40 N / 60 N	40 N / 60 N
Max. speed	max. 12000 rpm	max. 12000 rpm	max. 12000 rpm
Vibration resistance	100 m/s <sup>2</sup> (10 ... 500 Hz)	100 m/s <sup>2</sup> (10 ... 500 Hz)	100 m/s <sup>2</sup> (10 ... 500 Hz)
Shock resistance	1000 m/s <sup>2</sup> (6 ms)	1000 m/s <sup>2</sup> (6 ms)	1000 m/s <sup>2</sup> (6 ms)
Operating temperature	-40 °C ... +85 °C	-40 °C ... +85 °C	-40 °C ... +85 °C
Connection	cable / Bus cover	Cable / M23 / Bus cover	Cable / M23 / Bus cover
<b>Technical Data - electrical</b>			
Supply voltage	DC 10-30 V	DC 10-30 V	DC 10-30 V
Max. current w/o load	max. 250 mA	max. 250 mA	max. 250 mA
EMC	EN 61326: Class A	EN 61326: Class A	EN 61326: Class A
Resolution singleturn	10 - 14 Bit	10 - 16 Bit	10 - 14 Bit
Resolution multiturn	12 Bit	12 Bit	12 Bit
Output code	Binary	Binary	Binary
Profile/ protocol	Profibus DP with encoder profile class C2 (parameterizable)	CANopen according to DS 301 with profile DSP 406, programmable encoder according class C2	CAN 2.0 A
Programmable	Resolution, Preset, Direction	Resolution, Preset, Offset, Direction	Direction, Limit values
Integrated special functions	Speed, Acceleration, Operating time	Speed, Acceleration, Limit values, Operating time	
Baud rate	is automatically set within a range of 9.6 Kbaud through 12 Mbaud	set via DIP switches within a range of 10 through 1000 Kbit/s	set via DIP switches within a range of 10 through 1000 Kbit/s
Device address	adjustable with DIP switches, via fieldbus (optional)		
Bus termination resistor	set via DIP switches	set via DIP switches	set via DIP switches
Basic identifier		set via DIP switches	set via DIP switches
Page	158	162	166

## Standard Industrial Types - Absolute

### AC 58 with Fieldbus Interfaces



- Overall length: 63 mm for singleturn, 73 mm for multiturn, including bus cover
- The complete bus specific electronics is integrated in the bus cover
- Option: Display "tico"
- Diagnostic LEDs in the bus cover



Type	AC 58 - DeviceNet	AC 58 - Interbus	AC 58 - SUCOnet
<b>Technical Data - mechanical</b>			
Housing diameter	58 mm	58 mm	58 mm
Shaft diameter	6 mm ... 10 mm (Solid shaft) 10 mm ... 12 mm (Hub shaft)	6 mm ... 10 mm (Solid shaft) 10 mm ... 12 mm (Hub shaft)	6 mm ... 10 mm (Solid shaft) 10 mm ... 12 mm (Hubshaft)
Flange (Mounting of housing)	Synchro flange, Clamping flange, Tether, Square flange	Synchro flange, Clamping flange, Tether, Square flange	Synchro flange, Clamping flange, Tether, Square flange
Protection class shaft input	IP64 or IP67	IP64 or IP67	IP64 or IP67
Protection class housing	IP67	Connection bus cover: IP67 Connection cable or M23 (conin): IP64 (IP67 optional)	IP64
Shaft load axial / radial	40 N / 60 N	40 N / 60 N	40 N / 60 N
Max. speed	max. 12 000 rpm	max. 12 000 rpm	max. 12 000 rpm
Vibration resistance	100 m/s <sup>2</sup> (10 ... 500 Hz)	100 m/s <sup>2</sup> (10 ... 500 Hz)	100 m/s <sup>2</sup>
Shock resistance	1000 m/s <sup>2</sup> (6 ms)	1000 m/s <sup>2</sup> (6 ms)	1000 m/s <sup>2</sup>
Operating temperature	-40 °C ... +85 °C	-40 °C ... +70 °C	-10 °C ... +60 °C
Connection	cable / Bus cover	cable / Bus cover / M23	Cable
<b>Technical Data - electrical</b>			
Supply voltage	DC 10-30 V	DC 10-30 V	DC 10-30 V
Max. current w/o load	max. 250 mA	max. 250 mA	max. 200 mA
EMC	Noise emission according to EN 50081-2, Immunity to inter- ference according to EN 50082-2	Noise emission according to EN 50081-2, Immunity to inter- ference according to EN 50082-2	
EMC	EN 61326: Class A		EN 61326: class A
Resolution singleturn	10 - 14 Bit	10 - 12 Bit	10 - 13 Bit
Resolution multiturn	12 Bit	12 Bit	12 Bit
Output code	Binary	32 Bit binary	Binary
Interface	CAN High-Speed according to ISO/DIS 11898, CAN specifi- cation 2.0 A (11-Bit-Identifier)		
Profile/ protocol	DeviceNet according to Rev. 2.0, programmable encoder	ENCOM-Profil K3 = ID-Code 37, K2 = ID-Code 36	SUCOnet-K1 or Hengstler-G1
Programmable	Resolution, Preset, Direction	Resolution, Preset, Offset, Direction	Resolution, Direction
Output current		max. 4.5 A for bus cover with 2x M23, max. 2 A for all other connections	
Baud rate	set via DIP switches to 125, 250, 500 KBaud	500 KBaud	
Address switch			set via DIP switches
Bus termination resistor	set via DIP switches		set via DIP switches
MAC-ID	set via DIP switches		
Page	170	174	178

## Standard Industrial Types - Absolute

### AC 58 - SSI programmable



- Compact design: 59mm length for single or multturn
- Aids for start-up and operation: diagnostic LED, preset key with optical response
- Parameterization: resolution, code type, sense of rotation, output format, warning, alarm
- Parameters can be stored in a non-volatile memory



Type	AC 58 - SSI-P
<b>Technical Data - mechanical</b>	
Housing diameter	58 mm
Shaft diameter	6 mm ... 10 mm (Solid shaft) 10 mm ... 12 mm (Hub shaft)
Flange (Mounting of housing)	Synchro flange, Clamping flange, Tether, Square flange
Protection class shaft input	IP64 or IP67
Protection class housing	IP64 (IP67 optional)
Shaft load axial / radial	40 N / 60 N
Max. speed	max. 12000 rpm
Vibration resistance	100 m/s <sup>2</sup> (10 ... 500 Hz)
Shock resistance	1000 m/s <sup>2</sup> (6 ms)
Operating temperature	-40 °C ... +100 °C
Connection	Cable / M23
<b>Technical Data - electrical</b>	
Supply voltage	DC 10-30 V
Max. current w/o load	max. 250 mA
Resolution singleturn	10 - 17 Bit
Resolution multturn	12 Bit
Output code	Binary, Gray
Parameterization	Resolution, Code type, Direction, Output format, Warning, Alarm
Control inputs	Direction, Preset 1, Preset 2
Alarm output	Alarm bit
Status LED	Green = ok, red = alarm
Page	180

# Standard Industrial Types - Absolute

## AC 110 - BiSS / SSI



- Hollow shaft up to 50 mm
- Singleturn up to 17 Bit



Type	AC 110 - BiSS / SSI
<b>Technical Data - mechanical</b>	
Housing diameter	110 mm
Shaft diameter	50 mm (Hub shaft)
Protection class shaft input	IP50 or IP64
Protection class housing	IP40 or IP64
Max. speed	max. 1500 rpm
Vibration resistance	100 m/s <sup>2</sup> (10 ... 500 Hz)
Shock resistance	1000 m/s <sup>2</sup> (6 ms)
Operating temperature	-20 °C ... +70 °C
Connection	Cable / M23
<b>Technical Data - electrical</b>	
Supply voltage	-5%/ 10% DC 5 V / DC 10-30 V
Max. current w/o load	max. 120 mA
Resolution singleturn	10 - 17 Bit
Output code	Binary, Gray
Alarm output	Alarm bit (SSI Option), warning and alarm bit (BiSS)
Page	194

## Stainless Industrial Types - Incremental



Type	RI 59
<b>Special features</b>	<ul style="list-style-type: none"> <li>■ Stainless steel encoder with high protection class</li> <li>■ High corrosion resistance</li> <li>■ Use in the area of food production</li> <li>■ Applications: packing machines, bottling machines, washing plants, mixers, cranes, hoists, marine outfitters</li> </ul>
Number of pulses	1 ... 10 000
<b>Technical Data - mechanical</b>	
Housing diameter	58 mm
Shaft diameter	9.52 mm ... 10 mm (Solid shaft)
Flange (Mounting of housing)	Square flange 63.5 mm
Protection class shaft input	IP67
Protection class housing	IP67
Shaft load axial / radial	40 N / 60 N
Max. speed	max. 10 000 rpm
Vibration resistance	100 m/s <sup>2</sup> (10 ... 2000 Hz)
Shock resistance	1000 m/s <sup>2</sup> (6 ms)
Operating temperature	-10 °C ... +70 °C
Connection	Cable
<b>Technical Data - electrical</b>	
Supply voltage	DC 5 V / DC 10-30 V
Max. current w/o load	max. 30 mA
Max. pulse frequency	RS422: 300 kHz Push-pull: 200 kHz
Output	RS422 / Push-Pull / Push-pull complementary
Alarm output	NPN-O.C., max. 5 mA
Pulse shape	Square wave
Page	199

# Stainless Industrial Types - Absolute



- Compact and robust design, high corrosion resistance
- Protection class IP67
- Resolution up to 29 Bit (17 Bit ST, 12 Bit MT)
- Versions with cable or demontable bus cover



Type	AC 59 - BiSS/SSI	AC 59 / AC 61 - Parallel	AC 61 - Profibus
<b>Technical Data - mechanical</b>			
Housing diameter	58 mm	AC 59 - Parallel: 58 mm AC 61 - Parallel: 61.5 mm	61.5 mm
Shaft diameter	9.52 mm ... 10 mm (Solid shaft)	9.52 mm ... 10 mm (Solid shaft)	9.52 mm ... 10 mm (Solid shaft)
Flange (Mounting of housing)	Square flange 63.5 mm	Square flange 63.5 mm	Square flange 63.5 mm
Protection class shaft input	IP67	IP67	IP67
Protection class housing	IP67	IP67	IP67
Shaft load axial / radial	40 N / 60 N	40 N / 60 N	40 N / 60 N
Max. speed	max. 10 000 rpm	max. 10 000 rpm	max. 10 000 rpm
Vibration resistance	100 m/s <sup>2</sup> (10 ... 500 Hz)	100 m/s <sup>2</sup> (10 ... 500 Hz)	100 m/s <sup>2</sup> (10 ... 500 Hz)
Shock resistance	1000 m/s <sup>2</sup> (6 ms)	1000 m/s <sup>2</sup> (6 ms)	1000 m/s <sup>2</sup> (6 ms)
Operating temperature	-40 °C ... +100 °C	-40 °C ... +100 °C	-40 °C ... +85 °C
Connection	Cable	Cable	cable
<b>Technical Data - electrical</b>			
Supply voltage	-5%/ 10% DC 5 V / DC 10-30 V	DC 10-30 V	DC 10-30 V
Max. current w/o load	max. 100 mA	max. 300 mA	max. 250 mA
EMC			EN 61326: Class A
Resolution singleturn	10 - 17 Bit Gray Excess: 360, 720 increments	10 - 14 Bit Gray Excess: 360, 720 increments	10 - 14 Bit
Resolution multiturn	12 Bit	12 Bit	12 Bit
Output code	Binary, Gray	Binary, Gray, Gray Excess	Binary
Profile/ protocol			Profibus DP with encoder profile class C2 (parameterizable)
Parametrization	Code type, Direction, Warning, Alarm		
Programmable Integrated special functions			Resolution, Preset, Direction Speed, Acceleration, Operating time
Output current		30 mA per Bit, short-circuit-proof	
Control inputs	Direction	Latch, Direction, Tristate with ST, Tristate with MT	
Reset key	Disable via parameterization		
Alarm output	Alarm bit (SSI Option), warning and alarm bit (BiSS)	NPN-O.C., max. 5 mA	
Baud rate			is automatically set within a range of 9.6 Kbaud through 12 Mbaud
Device address			adjustable with DIP switches, via fieldbus (optional)
Bus termination resistor			set via DIP switches
Status LED	Green = ok, red = alarm	Green = ok, red = alarm	
Page	202	207	212

# Stainless Industrial Types - Absolute



CAN

CANopen

DeviceNet

- Compact and robust design, high corrosion resistance
- Protection class IP67
- Resolution up to 29 Bit (17 Bit ST, 12 Bit MT)
- Versions with cable or demountable bus cover



Type	AC 61 - CANopen	AC 61 - CANlayer2	AC 61 - DeviceNet
<b>Technical Data - mechanical</b>			
Housing diameter	61.5 mm	61.5 mm	61.5 mm
Shaft diameter	9.52 mm ... 10 mm (Solid shaft)	9.52 mm ... 10 mm (Solid shaft)	9.52 mm ... 10 mm (Solid shaft)
Flange (Mounting of housing)	Square flange 63.5 mm	Square flange 63.5 mm	Square flange 63.5 mm
Protection class shaft input	IP67	IP67	IP67
Protection class housing	IP67	IP67	IP67
Shaft load axial / radial	40 N / 60 N	40 N / 60 N	40 N / 60 N
Max. speed	max. 10000 rpm	max. 10000 rpm	max. 10000 rpm
Vibration resistance	100 m/s <sup>2</sup> (10 ... 500 Hz)	100 m/s <sup>2</sup> (10 ... 500 Hz)	100 m/s <sup>2</sup> (10 ... 500 Hz)
Shock resistance	1000 m/s <sup>2</sup> (6 ms)	1000 m/s <sup>2</sup> (6 ms)	1000 m/s <sup>2</sup> (6 ms)
Operating temperature	-40 °C ... +85 °C	-40 °C ... +85 °C	-40 °C ... +85 °C
Connection	Cable	Cable	cable
<b>Technical Data - electrical</b>			
Supply voltage	DC 10-30 V	DC 10-30 V	DC 10-30 V
Max. current w/o load	max. 250 mA	max. 250 mA	max. 250 mA
EMC			Noise emission according to EN 50081-2, Immunity to interference according to EN 50082-2
EMC	EN 61326: Class A	EN 61326: Class A	EN 61326: Class A
Resolution singleturn	10 - 16 Bit	10 - 14 Bit	10 - 14 Bit
Resolution multiturn	12 Bit	12 Bit	12 Bit
Output code	Binary	Binary	Binary
Interface			CAN High-Speed according to ISO/DIS 11898, CAN specification 2.0 A (11-Bit-Identifier)
Profile/ protocol	CANopen according to DS 301 with profile DSP 406, programmable encoder according class C2	CAN 2.0 A	DeviceNet according to Rev. 2.0, programmable encoder
Programmable	Resolution, Preset, Offset, Direction	Direction, Limit values	Resolution, Preset, Direction
Integrated special functions	Speed, Acceleration, Limit values, Operating time		
Baud rate	set via DIP switches within a range of 10 through 1000 Kbit/s	set via DIP switches within a range of 10 through 1000 Kbit/s	set via DIP switches to 125, 250, 500 Kbaud
Bus termination resistor	set via DIP switches	set via DIP switches	set via DIP switches
Basic identifier	set via DIP switches	set via DIP switches	
MAC-ID			set via DIP switches
Page	215	218	221



## Stainless Industrial Types - Absolute



- Compact and robust design, high corrosion resistance
- Protection class IP67
- Resolution up to 29 Bit (17 Bit ST, 12 Bit MT)
- Versions with cable or demountable bus cover



Type	AC 61 - Interbus	AC 61 - SSI-P
<b>Technical Data - mechanical</b>		
Housing diameter	61.5 mm	61.5 mm
Shaft diameter	9.52 mm ... 10 mm (Solid shaft)	9.52 mm ... 10 mm (Solid shaft)
Flange (Mounting of housing)	Square flange 63.5 mm	Square flange 63.5 mm
Protection class shaft input	IP67	IP67
Protection class housing	IP67	IP67
Shaft load axial / radial	40 N / 60 N	40 N / 60 N
Max. speed	max. 10 000 rpm	max. 10 000 rpm
Vibration resistance	100 m/s <sup>2</sup> (10 ... 500 Hz)	100 m/s <sup>2</sup> (10 ... 500 Hz)
Shock resistance	1000 m/s <sup>2</sup> (6 ms)	1000 m/s <sup>2</sup> (6 ms)
Operating temperature	-40 °C ... +70 °C	-40 °C ... +70 °C
Connection	cable	Cable
<b>Technical Data - electrical</b>		
Supply voltage	DC 10-30 V	DC 10-30 V
Max. current w/o load	max. 250 mA	max. 250 mA
EMC	Noise emission according to EN 50081-2, Immunity to interference according to EN 50082-2	
Resolution singleturn	10 - 12 Bit	10 - 17 Bit
Resolution multiturn	12 Bit	12 Bit
Output code	32 Bit binary	Binary, Gray
Profile/ protocol	ENCOM-Profil K3 = ID-Code 37, K2 = ID-Code 36	
Parametrization		Resolution, Code type, Direction, Output format, Warning, Alarm
Programmable	Resolution, Preset, Offset, Direction	
Output current	max. 4.5 A for bus cover with 2x M23, max. 2 A for all other connections	
Control inputs		Direction, Preset 1, Preset 2
Alarm output		Alarm bit
Baud rate	500 KBaud	
Status LED		Green = ok, red = alarm
Page	224	227

## EEx Industrial Types - Incremental



ATEX



Type	RX 70TI / RX 71TI
<b>Special features</b>	<ul style="list-style-type: none"> <li>■ Explosion proof class II according to EX II 2 G/D EEX d IIC T6/T4</li> <li>■ Highest working reliability</li> <li>■ Resolution up to 10 000 ppr</li> <li>■ Stainless steel version RX71 available</li> <li>■ Applications: enamelling production line, surfacing machines, bottling machines, mixers, silo works</li> </ul>
Number of pulses	1 ... 10 000
<b>Technical Data - mechanical</b>	
Housing diameter	70 mm
Shaft diameter	10 mm (Solid shaft)
Flange (Mounting of housing)	Clamping flange
Protection class shaft input	T4: IP64 or IP67 T6: IP64
Protection class housing	T4: IP65 or IP67 T6: IP65
Shaft load axial / radial	50 N / 100 N
Max. speed	max. 6000 rpm
Vibration resistance	10 g = 100 m/s <sup>2</sup> (10 ... 2000 Hz)
Shock resistance	100 g = 1000 m/s <sup>2</sup> (6 ms)
Ambient temperature	T4: -25 °C ... +60 °C T6: -25 °C ... +40 °C
Connection	Cable
<b>Technical Data - electrical</b>	
Supply voltage	DC 5 V / DC 10-30 V
Max. current w/o load	max. 30 mA
Max. pulse frequency	RS422: 300 kHz Push-pull: 200 kHz
Output	RS422 / Push-Pull / Push-pull complementary
Output current	RS 422: ±30 mA Push-pull with short-circuit protection: 30 mA (DC 10 - 30 V)
Alarm output	NPN-O.C., max. 5 mA
Pulse shape	Square wave
Page	236

# EEx Industrial Types - Absolute



ATEX



CANopen

- ATEX certification for gas and dust explosion proof, protection class up to IP67
- Same electrical performance as ACURO industry
- Resolution up to 29 Bit (17 Bit ST, 12 Bit MT)
- Diameter only 70 mm, robust design, also available with stainless steel housing



Type	AX 70 / AX 71 - SSI	AX 70 / AX 71 - Profibus	AX 70 / AX 71 - CANopen
<b>Technical Data - mechanical</b>			
Housing diameter	70 mm	70 mm	70 mm
Shaft diameter	10 mm (Solid shaft)	10 mm (Solid shaft)	10 mm (Solid shaft)
Flange (Mounting of housing)	Clamping flange	Clamping flange	Clamping flange
Protection class shaft input	T4: IP64 or IP67 T6: IP64	T4: IP64 or IP67 T6: IP64	T4: IP64 or IP67 T6: IP64
Protection class housing	T4: IP65 or IP67 T6: IP65	T4: IP65 or IP67 T6: IP65	T4: IP65 or IP67 T6: IP65
Shaft load axial / radial	40 N / 100 N	40 N / 100 N	40 N / 100 N
Max. speed	max. 6000 rpm	max. 6000 rpm	max. 6000 rpm
Vibration resistance	100 m/s <sup>2</sup> (10 ... 500 Hz)	100 m/s <sup>2</sup> (10 ... 500 Hz)	100 m/s <sup>2</sup> (10 ... 500 Hz)
Shock resistance	1000 m/s <sup>2</sup> (6 ms)	1000 m/s <sup>2</sup> (6 ms)	1000 m/s <sup>2</sup> (6 ms)
Ambient temperature	T4: -40 °C ... +60 °C T6: -40 °C ... +40 °C	T4: -40 °C ... +60 °C T6: -40 °C ... +40 °C	T4: -40 °C ... +60 °C T6: -40 °C ... +40 °C
Connection	Cable	Cable	Cable
<b>Technical Data - electrical</b>			
Max. current w/o load	max. 250 mA	max. 250 mA	max. 250 mA
Resolution singleturn	10 - 17 Bit	10 - 14 Bit	10 - 14 Bit
Resolution multiturn	12 Bit	12 Bit	12 Bit
Output code	Binary, Gray	Binary	Binary
Profile/ protocol		Profibus DP with encoder profile class C2 (parameterizable)	CANopen according to DS 301 with profile DSP 406, programmable encoder according class C2
Parametrization		Resolution, Preset, Direction	Resolution, Preset, Offset, Direction
Integrated special functions		Speed, Acceleration, Operating time	Speed, Acceleration, Rotary axis, Limit values, Operating time
Control inputs	Direction		
Alarm output	Alarm bit (SSI Option)		
Baud rate		is automatically set within a range of 9.6 Kbaud through 12 Mbaud	
Device address		set via Bus	
Bus termination resistor		external mounting	external mounting
Page	241	244	247



## Light Duty Types - Incremental



Type	PC 9 / PC 9S	RI 32	RI 38
<b>Special features</b>	<ul style="list-style-type: none"> <li>■ Provides digital control inputs from operators's panel</li> <li>■ Bidirectional squarewave signal outputs</li> <li>■ Up to 512 increments</li> <li>■ Continuous and reversible rotation</li> <li>■ Non-contacting</li> <li>■ Operating temperature -40 ... 100 °C</li> </ul>	<ul style="list-style-type: none"> <li>■ Replacement for type Typ RIS and RI 31</li> <li>■ The economical encoder for small appliances</li> <li>■ High efficiency by means of ball bearing</li> <li>■ Small torque</li> <li>■ Applications: laboratory equipment, training equipment, crimping machines, tampon printing machines, miniature grinding machines</li> </ul>	<ul style="list-style-type: none"> <li>■ Replacement for type RI 39</li> <li>■ Encoder for universal installation by means of front/back panel mounting</li> <li>■ High efficiency by means of ball bearing</li> <li>■ Small torque</li> <li>■ Applications: FHP motors, laboratory equipment, labeling machines, plotters, length measuring machines</li> </ul>
Number of pulses	100 ... 512	5 ... 1500	5 ... 1024
<b>Technical Data - mechanical</b>			
Housing diameter	PC 9: 22 mm PC 9S: 22.86 mm	30 mm	39 mm
Shaft diameter	3.175 mm ... 6.35 mm	5 mm ... 6 mm (Solid shaft)	6 mm (Solid shaft)
Flange (Mounting of housing)		Pilot flange	Square flange
Protection class shaft input		IP40	IP40
Protection class housing		IP50	IP50
Shaft load axial / radial	1/8" shaft: 4 N / 27 N 1/4" shaft: 4 N / 4 N	5 N / 10 N	5 N / 10 N
Max. speed		max. 6000 rpm	max. 10 000 rpm
Vibration resistance		100 m/s <sup>2</sup> (10 ... 2000 Hz)	100 m/s <sup>2</sup> (10 ... 2000 Hz)
Shock resistance		1000 m/s <sup>2</sup> (6 ms)	1000 m/s <sup>2</sup> (6 ms)
Operating temperature	-40 °C ... +100 °C	-10 °C ... +60 °C	-10 °C ... +60 °C
Connection	PC 9: 10 pole header PC 9S: 5 pole header	Cable	Cable
<b>Technical Data - electrical</b>			
Supply voltage	DC 5 V ±10 %	DC 5 V / DC 10-30 V	DC 5 V / DC 10-30 V
Max. current w/o load		max. 30 mA	max. 30 mA
Max. pulse frequency	200 kHz	DC 5 V: 300 kHz DC 10 - 30 V: 200 kHz	DC 5 V: 300 kHz DC 10 - 30 V: 200 kHz
Output		Push-Pull	Push-Pull
Output signals	min. 2.5 V high (VOH), max. 0.5 V low (VOL)		
Output current	PC 9: 3 mA sink/source (25 °C), 2 mA (100 °C) PC 9S: 6 mA sink/source (25 °C), 4 mA (100 °C)		
Alarm output		NPN-O.C., max. 5 mA	NPN-O.C., max. 5 mA
Pulse shape	Square wave	Square wave	Square wave
Page	256	259	262

## Light Duty Types - Incremental



Type	RI 41	RI 42
<b>Special features</b>	<ul style="list-style-type: none"> <li>■ Replacement for type RIM</li> <li>■ Economical miniature encoder</li> <li>■ Up to 14,400 steps with 3,600 pulses</li> <li>■ High mechanical efficiency</li> <li>■ Applications: wood working machines, FHP motors, graphic machines, table robots</li> </ul>	<ul style="list-style-type: none"> <li>■ Economical miniature encoder</li> <li>■ High protection IP65</li> <li>■ Output Push-pull or NPN-O.C.</li> <li>■ High mechanical efficiency</li> <li>■ Applications: textile machinery</li> </ul>
Number of pulses	5 ... 3600	5 ... 1024
<b>Technical Data - mechanical</b>		
Housing diameter	40 mm	40 mm
Shaft diameter	6 mm (Solid shaft)	6 mm (Solid shaft)
Flange (Mounting of housing)	Pilot flange	Pilot flange
Protection class shaft input	IP40	IP64
Protection class housing	IP50	IP65
Shaft load axial / radial	5 N / 10 N	5 N / 10 N
Max. speed	max. 10 000 rpm	max. 10 000 rpm
Vibration resistance	100 m/s <sup>2</sup> (10 ... 2000 Hz)	100 m/s <sup>2</sup> (10 ... 2000 Hz)
Shock resistance	1000 m/s <sup>2</sup> (6 ms)	1000 m/s <sup>2</sup> (6 ms)
Operating temperature	-10 °C ... +70 °C	0 °C ... +60 °C
Connection	Cable	Cable
<b>Technical Data - electrical</b>		
Supply voltage	DC 5 V / DC 10-30 V	DC 5 V / DC 10-30 V / DC 10-24 V
Max. current w/o load	max. 30 mA	max. 40 mA
Max. pulse frequency	DC 5 V: 300 kHz DC 10 - 30 V: 200 kHz	DC 5 V: 300 kHz DC 10 - 30 V: 200 kHz DC 10 - 24 V: 50 kHz
Output	Push-Pull	Push-Pull / Push-pull complementary / NPN-O.C.
Alarm output	NPN-O.C., max. 5 mA	NPN-O.C., max. 5 mA
Pulse shape	Square wave	Square wave
Page	265	268

## Motor Feedback - Kit Encoders

### Miniature, DC & Stepper Motors



Type	E 9	M 9	M 14
<b>Special features</b>	<ul style="list-style-type: none"> <li>■ Ideal for position and speed sensing in small machines and actuators</li> <li>■ Low power standby mode is ideal for battery powered devices</li> <li>■ Max. output frequency: 200 kHz</li> <li>■ Resolution to 512 lines/rev</li> </ul>	<ul style="list-style-type: none"> <li>■ Ideal for position and speed sensing in small machines and actuators</li> <li>■ Max. output frequency: 200 kHz</li> <li>■ Resolution to 512 lines/rev</li> </ul>	<ul style="list-style-type: none"> <li>■ Ideal economical feedback device for servo and step motors</li> <li>■ Short axial length and compact 1.5 inch diameter</li> <li>■ Easy "snap-on" installation</li> <li>■ High resolution to 1024 lines/rev and 200 kHz bandwidth</li> <li>■ Max. output frequency: 200 kHz</li> <li>■ Replacement for HP 5540</li> <li>■ CE qualified</li> </ul>
Number of pulses	100 ... 512	100 ... 512	200 ... 1024
<b>Technical Data - mechanical</b>			
Housing diameter	22 mm	22 mm	38 mm
Mounting depth	20 mm	14.8 mm	17.2 mm
Shaft diameter	1.5 mm ... 3.962 mm (Hub shaft)	1.5 mm ... 3.962 mm (Hub shaft)	3 mm ... 19.05 mm (Hub shaft)
Max. speed	max. 12 000 rpm	max. 12 000 rpm	max. 12 000 rpm
Operating temperature	-40 °C ... +100 °C	-40 °C ... +100 °C	-40 °C ... +100 °C
Connection	10 pole header	5 pole header	5 pole header
<b>Technical Data - electrical</b>			
Supply voltage	DC 5 V ±10 %	DC 5 V ±10 %	DC 5 V ±10 %
Max. current w/o load	max. 10 mA	max. 10 mA	max. 10 mA
Max. pulse frequency	200 kHz	200 kHz	200 kHz
Output	TTL	TTL	TTL
Output signals	min. 2.5 V high (VOH), max. 0.5 V low (VOL)	min. 2.5 V high, max. 0.5 V low	min. 2.5 V high, max. 0.5 V low
Output current	3 mA sink/source (25°C), 2 mA (100°C)	6 mA (25°C), 4 mA (100°C)	6 mA (25°C), 4 mA (100°C)
Pulse shape	Square wave		
Page	272	275	278

## Motorfeedback - Incremental Types

### Asynchronous & DC Motors



Type	RI 36-H	RI 58-D / RI 58TD	RI 58-G / RI 58TG
<b>Special features</b>	<ul style="list-style-type: none"> <li>■ Miniature industry encoder for high number of pulses</li> <li>■ Short mounting length</li> <li>■ Easy mounting procedure</li> <li>■ Applications: motors, machine tools, robots, automated SMD equipment</li> </ul>	<ul style="list-style-type: none"> <li>■ Direct mounting without coupling</li> <li>■ Flexible hollow shaft design up to diameter 14 mm</li> <li>■ Through hollow shaft or as end shaft (blind shaft)</li> <li>■ Easy installation by means of clamping shaft or blind shaft</li> <li>■ Short overall length of 33 mm</li> <li>■ Fixing of flange by means of a stator coupling or set screw</li> <li>■ Various shaft versions</li> <li>■ Applications: actuators, motors</li> <li>■ Operating temperature up to 100 °C (RI 58TD)</li> </ul>	<ul style="list-style-type: none"> <li>■ Direct mounting without coupling</li> <li>■ Through hollow shaft Ø 14 mm and 15 mm</li> <li>■ Easy installation by means of clamping ring</li> <li>■ Fixing of flange by means of a stator coupling or set screw</li> <li>■ Applications: actuators, motors</li> </ul>
Number of pulses	5 ... 3600	1 ... 5000	50 ... 2500
<b>Technical Data - mechanical</b>			
Housing diameter	36 mm	58 mm	58 mm
Shaft diameter	4 mm ... 10 mm (Hubshaft)	10 mm ... 12 mm (Through hollow shaft) 10 mm ... 14 mm (Hubshaft)	14 mm ... 15 mm (Through hollow shaft)
Flange (Mounting of housing)	Tether	Synchro flange	Synchro flange
Protection class shaft input	IP64	IP64	IP64
Protection class housing	IP64	Through hollow shaft - D: IP64 Hubshaft - E,F: IP65	IP64
Max. speed	max. 10000 rpm	max. 4000 rpm	max. 4000 rpm
Vibration resistance	100 m/s <sup>2</sup> (10 ... 2000 Hz)	10 g = 100 m/s <sup>2</sup> (10 ... 2000 Hz)	10 g = 100 m/s <sup>2</sup> (10 ... 2000 Hz)
Shock resistance	1000 m/s <sup>2</sup> (6 ms)	100 g = 1000 m/s <sup>2</sup> (6 ms)	100 g = 1000 m/s <sup>2</sup> (6 ms)
Operating temperature	-10 °C ... +70 °C	RI 58-D: -10 °C ... +70 °C RI 58TD: -25 °C ... +100 °C	RI 58-G: -10 °C ... +70 °C RI 58TG: -10 °C ... +100 °C
Connection	Cable	Cable / M23	Cable
<b>Technical Data - electrical</b>			
Supply voltage	DC 5 V / DC 10-30 V	DC 5 V / DC 10-30 V	DC 5 V / DC 10-30 V
Max. current w/o load	max. 30 mA	max. 30 mA	max. 30 mA
Max. pulse frequency	RS422: 300 kHz Push-pull: 200 kHz	RS422: 300 kHz Push-pull: 200 kHz	RS422: 300 kHz Push-pull: 200 kHz
Output	RS422 / Push-Pull / Push-pull complementary	RS422 / Push-Pull / Push-pull complementary	RS422 / Push-Pull / Push-pull complementary
Alarm output	NPN-O.C., max. 5 mA	NPN-O.C., max. 5 mA	NPN-O.C., max. 5 mA
Pulse shape	Square wave	Square wave	Square wave
Page	104	113	122



## Motorfeedback - Incremental Types

### Asynchronous & DC Motors

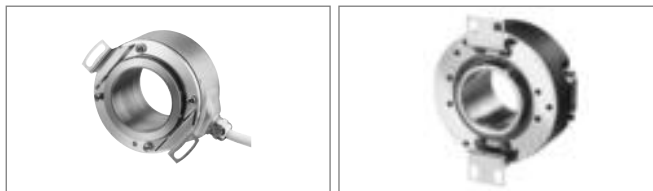

Type	RI 76TD	RI 80-E
<b>Special features</b>	<ul style="list-style-type: none"> <li>■ Through hollow shaft Ø 15 bis 42 mm</li> <li>■ Outside diameter only 76 mm</li> <li>■ Easy installation by means of clamping ring front or rear</li> <li>■ Operating temperature up to 100 °C</li> <li>■ Applications: motors, printing machines, lifts</li> </ul>	<ul style="list-style-type: none"> <li>■ Incremental</li> <li>■ 30 - 45 mm hollow shaft</li> <li>■ Rugged mechanical design</li> <li>■ Unbreakable disc</li> <li>■ Integrated diagnostic system</li> <li>■ Wide voltage range DC 5 - 30 V</li> <li>■ Isolated shaft</li> </ul>
Number of pulses	1 ... 10 000	1024, 2048, 2500, 4096, 5000, 10 000 (other number of pulses on request)
<b>Technical Data - mechanical</b>		
Housing diameter	76 mm	100 mm
Shaft diameter	15 mm ... 40 mm (Hub shaft)	10 mm ... 12 mm (Through hollow shaft)
Flange (Mounting of housing)	Tether	Tether
Protection class shaft input	IP40 or IP64	IP50 or IP64
Protection class housing	IP50 (IP65 optional)	IP50 or IP64
Max. speed	max. 1800 rpm	max. 1500 rpm
Vibration resistance	10 g = 100 m/s <sup>2</sup> (10 ... 2000 Hz)	
Shock resistance	100 g = 1000 m/s <sup>2</sup> (6 ms)	
Operating temperature	-25 °C ... +100 °C	-25 °C ... +85 °C
Connection	Cable	Sub-D
<b>Technical Data - electrical</b>		
Supply voltage	DC 5 V / DC 10-30 V	DC 5 V ±10 % / DC 5-30 V
Max. current w/o load	max. 35 mA	max. 35 mA
Max. pulse frequency	RS422: 300 kHz Push-pull: 200 kHz	RS422: 600 kHz Push-pull: 200 kHz
Output	RS422 / Push-Pull / Push-pull complementary	RS422 / Push-Pull / Push-pull complementary
Alarm output	NPN-O.C., max. 5 mA	NPN-O.C., max. 5 mA
Pulse shape	Square wave	Square wave
Page	132	136

# Motorfeedback - Absolute Types

## Asynchronous & DC Motors



Type	AC 58 - BiSS / SSI	AC 110 - BiSS / SSI
<b>Special features</b>	<ul style="list-style-type: none"> <li>■ Compact design: 50 mm length for single or multiturn</li> <li>■ Aids for start up and operation: diagnostic LED, preset key with optical response, status information</li> <li>■ Use of sine/ cosine signals for fast control task possible</li> <li>■ Control input: Direction</li> <li>■ Resolution up to 29 Bit</li> </ul>	<ul style="list-style-type: none"> <li>■ Same electrical performance as ACURO industry</li> <li>■ Robust bearings for long life</li> <li>■ Hollow shaft up to 50 mm</li> <li>■ Absolute singleturn</li> <li>■ Revolution 11-17 Bit</li> <li>■ BiSS or SSI interface</li> <li>■ Optional: Sine-Cosine 4096 increments</li> <li>■ DC 5 or 10 - 30 V</li> <li>■ Integrated diagnostic system</li> </ul>
<b>Technical Data - mechanical</b>		
Housing diameter	58 mm	110 mm
Shaft diameter	6 mm ... 10 mm (Solid shaft) 10 mm ... 12 mm (Hub shaft)	50 mm (Hub shaft)
Flange (Mounting of housing)	Synchro flange, Clamping flange, Tether, Square flange	
Protection class shaft input	IP64 or IP67	IP50 or IP64
Protection class housing	IP64 or IP67	IP40 or IP64
Shaft load axial / radial	40 N / 60 N	
Max. speed	max. 12000 rpm	max. 1500 rpm
Vibration resistance	100 m/s <sup>2</sup> (10 ... 2000 Hz)	100 m/s <sup>2</sup> (10 ... 500 Hz)
Shock resistance	1000 m/s <sup>2</sup> (6 ms)	1000 m/s <sup>2</sup> (6 ms)
Operating temperature	-40 °C ... +100 °C	-20 °C ... +70 °C
Connection	Cable / M23 / M12	Cable / M23
<b>Technical Data - electrical</b>		
Supply voltage	-5% / 10% DC 5 V / DC 10-30 V	-5% / 10% DC 5 V / DC 10-30 V
Max. current w/o load	max. 100 mA	max. 120 mA
Resolution singleturn	10 - 17 Bit Gray Excess: 360, 720 increments	10 - 17 Bit
Resolution multiturn	12 Bit	
Output code	Binary, Gray	Binary, Gray
Parametrization	Code type, Direction, Warning, Alarm	
Control inputs	Direction	
Reset key	Disable via parameterization	
Alarm output	Alarm bit (SSI Option), warning and alarm bit (BiSS)	Alarm bit (SSI Option), warning and alarm bit (BiSS)
Status LED	Green = ok, red = alarm	
Page	147	194

# Motor Feedback - Incremental Types

## AC-Synchronous & BLDC Motors



Type	M 53
<b>Special features</b>	<ul style="list-style-type: none"> <li>■ Modular hollow shaft encoder, ideal for BLDC, DC-Servo and Stepper feedback</li> <li>■ Through hollow shaft Ø 6 ... 12,7 mm</li> <li>■ Incremental + Commutation</li> <li>■ Incremental signals A, B, N and 4, 6 or 8 pole</li> <li>■ Outside diameter 53 mm</li> <li>■ Mounting depth: only 23 mm</li> <li>■ Maximum speed: 12 000 rpm</li> <li>■ Standard Operating temperature: -40 ... +120°C</li> <li>■ Easy installation and alignment</li> </ul>
<b>Technical Data - mechanical</b>	
Housing diameter	53 mm
Mounting depth	22.9 mm
Shaft diameter	6 mm ... 12.7 mm (Hub shaft)
Protection class shaft input	IP50
Protection class housing	with cover: IP50
Max. speed	max. 12 000 rpm
Vibration resistance	25 m/s <sup>2</sup> (5 ... 2000 Hz)
Shock resistance	500 m/s <sup>2</sup> (11 msec)
Operating temperature	-40 °C ... +120 °C
Connection	Shielded cable or dual row connector
<b>Technical Data - electrical</b>	
Supply voltage	DC 5 V or DC 12 V ±10 %
Max. current w/o load	max. 75 mA
Max. pulse frequency	200 kHz
Page	283

## Motor Feedback - Comcoders

### AC-Synchronous & BLDC Motors



Type	F 10	F 15	F 21
<b>Special features</b>	<ul style="list-style-type: none"> <li>■ Compact hollowshaft motor encoder, ideal for BLDC, DC-Servo and Stepper feedback</li> <li>■ Through hollow shaft Ø 6 mm</li> <li>■ Incremental signals A, B, N</li> <li>■ Resolution up to 2048 ppr</li> <li>■ 6 or 10 pole commutation signals</li> <li>■ Frequency response to 300 kHz</li> <li>■ Resolver compatible mounting</li> <li>■ Operating temperature up to 120 °C</li> <li>■ Mounting depth: 22.4 mm</li> </ul>	<ul style="list-style-type: none"> <li>■ Compact hollowshaft motor encoder, ideal for BLDC, DC-Servo and Stepper feedback</li> <li>■ Through hollow shaft Ø 9.52 mm</li> <li>■ Incremental signals A, B, N</li> <li>■ Resolution up to 2048 ppr</li> <li>■ 6, 8 or 10 pole commutation signals</li> <li>■ Frequency response to 300 kHz</li> <li>■ Resolver compatible mounting</li> <li>■ Operating temperature up to 120 °C</li> <li>■ Mounting depth: 22.4 mm</li> </ul>	<ul style="list-style-type: none"> <li>■ Compact hollowshaft motor encoder, ideal for BLDC, DC-Servo and Stepper feedback</li> <li>■ Through hollow shaft Ø 12.7 mm</li> <li>■ Incremental signals A, B, N</li> <li>■ Resolution up to 2048 ppr</li> <li>■ 6, 8, 10, 12 or 16 pole commutation signals</li> <li>■ Frequency response to 300 kHz</li> <li>■ Resolver compatible mounting</li> <li>■ Operating temperature up to 120 °C</li> <li>■ Mounting depth max.: 26 mm</li> </ul>
Number of pulses	1024, 2048	1024, 2048	1024, 2048
<b>Commutation</b>	optional additional 6 or 10 pole commutation signals	optional additional 6, 8 or 10 pole commutation signals	optional additional 6, 8, 10, 12 or 16 pole commutation signals
<b>Technical Data - mechanical</b>			
Housing diameter	31.7 mm	36.8 mm	53 mm
Mounting depth	22.5 mm	22.1 mm	26 mm
Shaft diameter	6 mm (Hub shaft)	9.52 mm (Through hollow shaft)	12.7 mm (Hub shaft)
Flange (Mounting of housing)	Servo flange	Servo flange	Servo flange
Max. speed	max. 12 000 rpm	max. 12 000 rpm	max. 12 000 rpm
Vibration resistance	2.5 g at 5 to 2000 Hz	2.5 g at 5 to 2000 Hz	2.5 g at 5 to 2000 Hz
Shock resistance	50 g for 6 ms duration	50 g for 6 ms duration	50 g for 6 ms duration
Operating temperature	0 °C ... +120 °C	0 °C ... +120 °C	0 °C ... +120 °C
Connection	Flying leads	Flying leads	Flying leads
<b>Technical Data - electrical</b>			
Supply voltage	DC 5 V ±10 %	DC 5 V ±10 %	DC 5 V ±10 %
Max. current w/o load	max. 100 mA	max. 100 mA	max. 100 mA
Max. pulse frequency	300 kHz	300 kHz	300 kHz
Output current	Incremental: ±40 mA (RS422) Commutation: 8 mA (NPN-O.C) or ±40 mA (RS 422)	Incremental: max. ±40 mA (RS 422) Commutation: max. ±8 mA (NPN-O.C) or ±40 mA (RS 422)	Incremental: ±40 mA (RS 422) Commutation: 8 mA (NPN-O.C) or ±40 mA (RS 422)
Page	285	289	292

## Motor Feedback - Incremental Types

### AC-Synchronous & BLDC Motors



Type	HC 20	RF 53
<b>Special features</b>	<ul style="list-style-type: none"> <li>■ Compact hollowshaft motor encoder, ideal for BLDC, DC servo and Stepper feedback</li> <li>■ Incremental + commutation</li> <li>■ Phased Array Technology</li> <li>■ Frequency response to 500 kHz</li> <li>■ Operating temperature up to 120 °C</li> <li>■ Outside diameter 50 mm</li> <li>■ Cable plug-in radial/axial</li> </ul>	<ul style="list-style-type: none"> <li>■ Solid shaft motor encoder for BLDC and gearless elevator traction machines</li> <li>■ Incremental + commutation</li> <li>■ Up to 10 000 ppr</li> <li>■ Operating temperature up to 120 °C</li> <li>■ IP54</li> <li>■ Outside diameter 53 mm</li> </ul>
Number of pulses		500 ... 10 000
<b>Technical Data - mechanical</b>		
Housing diameter	50 mm	53 mm
Mounting depth	36"	
Shaft diameter	6 mm ... 9 mm	Cone solid shaft
Flange (Mounting of housing)	Tether	Tether
Protection class shaft input	IP50	IP54
Protection class housing	IP50	IP54
Shaft load axial / radial		20 N / 90 N
Max. speed	max. 12 000 rpm	max. 5000 rpm
Vibration resistance		25 m/s <sup>2</sup>
Shock resistance		1000 m/s <sup>2</sup>
Operating temperature	0 °C ... +120 °C	-20 °C ... +120 °C
Connection	Cable	Cable / Sub-D / PCB
<b>Technical Data - electrical</b>		
Supply voltage		DC 5 V ±10 %
Max. current w/o load	max. 175 mA	max. 100 mA
Max. pulse frequency	500 kHz	100 kHz
Output		NPN-O.C. / RS422
Page	296	300

# Motor Feedback - Absolute Types

## Asynchronous & DC Motors



Type	AD 34	AD 35	AD 36
<b>Special features</b>	<ul style="list-style-type: none"> <li>■ For brushless servo motors</li> <li>■ Light duty encoder</li> <li>■ Notched shaft 6 mm</li> <li>■ Mounting Depth: 25 mm</li> <li>■ Up to 17 Bit Resolution</li> <li>■ +120°C operating temperature</li> <li>■ 10 000 rpm continuous operation</li> <li>■ BiSS or SSI interface</li> <li>■ Sinewave 1 Vpp</li> <li>■ Bandwidth 500 kHz</li> </ul>	<ul style="list-style-type: none"> <li>■ Shortest absolute encoder world wide</li> <li>■ Mounting depth: 23.65 mm</li> <li>■ Hub shaft 8 mm</li> <li>■ Resolution up to 22 Bit Singleturn</li> <li>■ +120°C operating temperature</li> <li>■ 10 000 rpm continuous operation</li> <li>■ BiSS or SSI interface</li> <li>■ Bandwidth 500kHz</li> </ul>	<ul style="list-style-type: none"> <li>■ For brushless servo motors</li> <li>■ Resolver size 15 compatible</li> <li>■ Through hollow shaft 8 mm</li> <li>■ 19 Bit Singleturn + 12 Bit Multiturn</li> <li>■ +120°C operating temperature</li> <li>■ 10,000 rpm continuous operation</li> <li>■ Optical encoder with a true geared multiturn</li> <li>■ BiSS or SSI interface</li> <li>■ Sinewave 1 Vpp</li> <li>■ Bandwidth 500 kHz</li> </ul>
Number of pulses	2048	2048	2048
<b>Technical Data - mechanical</b>			
Housing diameter	37.5 mm	37.5 mm	37.5 mm
Shaft diameter	6 mm (Notched Shaft)	8 mm (Hubshaft)	8 mm (Through hollow shaft) 8 mm (Hubshaft)
Flange (Mounting of housing)	Tether	Tether	Tether
Protection class shaft input	IP40	IP40	IP40
Protection class housing	IP40	IP40	IP40
Max. speed	max. 12 000 rpm	max. 12 000 rpm	max. 12 000 rpm
Vibration resistance	100 m/s <sup>2</sup> (10 ... 2000 Hz)	100 m/s <sup>2</sup> (10 ... 2000 Hz)	100 m/s <sup>2</sup> (10 ... 2000 Hz)
Shock resistance	1000 m/s <sup>2</sup> (6 ms)	1000 m/s <sup>2</sup> (6 ms)	1000 m/s <sup>2</sup> (6 ms)
Operating temperature	-15 °C ... +120 °C	-15 °C ... +120 °C	-15 °C ... +120 °C
Connection	Cable / PCB	Cable / PCB	Cable / PCB
<b>Technical Data - electrical</b>			
Supply voltage	DC 5 V -5 %/+10 % or DC 7 - 30 V	DC 5 V -5 %/+10 % or DC 7 - 30 V	DC 5 V -5 %/+10 % or DC 7 - 30 V
Max. current w/o load	max. 50 mA	max. 50 mA	max. 100 mA
Resolution singleturn	12 - 17 Bit	12 - 22 Bit	12 - 19 Bit (BiSS) 12 - 17 Bit (SSI)
Resolution multiturn		12 Bit	12 Bit
Output code	Gray	Gray	Gray
Alarm output	Alarm bit (SSI Option), warning bit and alarm bit (BiSS)	Alarm bit (SSI Option), warning and alarm bit (BiSS)	Alarm bit (SSI Option), warning and alarm bit (BiSS)
Page	304	307	310

# Motor Feedback - Absolute Types

## AC-Synchronous & BLDC Motors



Type	AD 58
<b>Special features</b>	<ul style="list-style-type: none"> <li>■ For brushless servo motors</li> <li>■ All-digital and highspeed</li> <li>■ +120°C operating temperature</li> <li>■ 10 000 rpm continuous operation</li> <li>■ Optical encoder with a true geared multiturn</li> <li>■ BiSS or SSI interface</li> <li>■ Option Sinewave 1 Vpp: Harmonic distortion less than 1%</li> <li>■ Bandwidth 500 kHz</li> </ul>
Number of pulses	2048
<b>Technical Data - mechanical</b>	
Housing diameter	58 mm
Shaft diameter	10 mm (Cone hollow shaft) 10 mm (Cone solid shaft)
Flange (Mounting of housing)	Tether
Protection class shaft input	IP40
Protection class housing	IP40
Max. speed	max. 12 000 rpm
Vibration resistance	100 m/s <sup>2</sup> (10 ... 2000 Hz)
Shock resistance	1000 m/s <sup>2</sup> (6 ms)
Operating temperature	-15 °C ... +120 °C
Connection	PCB
<b>Technical Data - electrical</b>	
Supply voltage	± 10% DC 5 V or DC 10 - 30 V
Max. current w/o load	max. 100 A
Resolution singleturn	13 Bit (SSI) max. 22 Bit (BiSS)
Resolution multiturn	12 Bit
Output code	Binary, Gray
Parametrization	Resolution, Code type, Direction, Warning, Alarm
Alarm output	Alarm bit (SSI Option), warning and alarm bit (BiSS)
Page	314

## Motor Feedback - Sine-wave Types

### AC-Synchronous & BLDC Motors



Type	S 21
<b>Special features</b>	<ul style="list-style-type: none"> <li>■ Wide operating temperature range of <math>-15\text{ }^{\circ}\text{C}</math> up to <math>+120\text{ }^{\circ}\text{C}</math>, therefore optimum use of motor capacity</li> <li>■ High limiting frequency with excellent signal quality, allowing highest peak speeds and reduced non-productive time wastage</li> <li>■ Excellent immunity to interference (EN 61000-4-4, Class 4)</li> <li>■ High functional safety due to signal control and system monitoring (under-voltage, pollution, disc damage, end of LED service life)</li> <li>■ High signal quality through control and error compensation</li> </ul>
Number of pulses	2048
<b>Technical Data - mechanical</b>	
Housing diameter	53 mm
Shaft diameter	Cone 1/10
Protection class shaft input	IP40
Protection class housing	IP40
Shaft load axial / radial	for tapered solid shaft: 20 N / 90 N
Max. speed	max. 15000 rpm
Vibration resistance	$\leq 100\text{ m/s}^2$ (10 ... 2,000 Hz)
Shock resistance	$\leq 1,000\text{ m/s}^2$ (6 ms)
Operating temperature	$-15\text{ }^{\circ}\text{C}$ ... $+120\text{ }^{\circ}\text{C}$
Connection	PCB connector and cable
<b>Technical Data - electrical</b>	
Supply voltage	DC 5 V $\pm 10\%$
Max. current w/o load	max. 120 mA
Page	317



# Motor Feedback - Resolvers



Type	Frameless Resolvers	Housed Industry Resolvers R 25	Housed Resolvers Series R 11
<b>Special features</b>	<ul style="list-style-type: none"> <li>■ Provide accurate, absolute position feedback</li> <li>■ Rugged and able to withstand high shock and vibration levels</li> <li>■ Impervious to most industrial contaminant and temperature extremes</li> <li>■ High temperature up to 220°C</li> <li>■ Operation in non electro-conductive liquids possible</li> <li>■ Maintenance-free (brushless)</li> <li>■ Aging resistant (no electronic components)</li> <li>■ Low-priced</li> <li>■ Applications: Servo drives, medical technologie (sterilisable), robots, gearless drives, military engineering</li> </ul>	<ul style="list-style-type: none"> <li>■ Rugged housing with IP65</li> <li>■ Able to withstand high shock and vibration levels</li> <li>■ Insensitive to most industrial contaminant and temperature extremes</li> <li>■ High temperature up to 125°C</li> <li>■ Flange- and servo-mount styles</li> </ul>	<ul style="list-style-type: none"> <li>■ Brushless construction</li> <li>■ Rugged housing</li> <li>■ Maintenance free</li> <li>■ Able to withstand high shock and vibration levels</li> <li>■ Insensitive to most industrial contaminant and temperature extremes</li> <li>■ High temperature up to 115°C</li> </ul>
Page	320	321	321

## Application Examples for Encoders

### Encoder Applications:

- Packaging industry
- Food industry
- Medical technology
- Elevators
- Conveyor systems
- Robotics
- Cranes
- Positioning control
- Electronics
- Baggage conveyor systems
- Metalworking
- Motors
- Servo motors
- Vector drives
- Mechanical engineering
- Turning machines
- Stamping machines
- Bending machines
- Welding systems
- Sawing machines
- etc.

## Application Examples with Encoders



# Application Examples with Motor Encoders



## Heavy Duty Types

**HEAVY DUTY**

**ACURO<sup>®</sup> -XR<sub>Robust</sub>** HENGSTLER

**NorthStar**

Hengstler offers a new series of incremental and absolute encoders in compact size that provide the ruggedness of big magnetic ring kit encoders. Choose from a growing line of Heavy Duty encoders designed to provide reliable operation in harsh duty industrial applications that will not corrode and can withstand temperature extremes from -40°C to +100°C

Hengstler's Heavy Duty product line offers extreme shock and vibration resistance, special labyrinth sealing options on select models, hazardous environment ATEX certification as well as extreme corrosion and wash down resistant stainless and nickel plated models designed for the special application needs of the food and beverage industry among others.

Heavy  
Duty

### Examples of applications for Heavy Duty encoders:

- wind power plants
- commercial solar plants
- oil field exploration
  - draw works
  - rough necks
- construction machinery
- utility vehicles/ trucks
- steel mills
- paper mills
- saw mills
- gantry cranes
- marine equipment
- offshore applications
- food & beverage
- filling plants
- paper processing
- converting machinery
- material handling
- your individual application

## Incremental



- Single or Dual output
- ATEX Certification available for Intrinsically Safe application
- High Resolution Unbreakable Disk
- Industrial Duty Connector
- NEMA 4X / IP67 Rated
- Nickel or Stainless Steel Housing available

**HEAVY DUTY**

**NorthStar** 

### NUMBER OF PULSES

0001 / 0024 / 0025 / 0035 / 0040 / 0060 / 0100 / 0120 / 0192 / 0200 / 0240 / 0250 / 0256 / 0300 / 0360 / 0500 / 0512 / 0600 / 0625 / 0720 / 1000 / 1024 / 1200 / 1250 / 1440 / 2000 / 2048 / 2500 / 2540 / 3600

### GENERAL INFORMATION

#### HARSH-DUTY OPTICAL ENCODER

The HD20 Harsh-Duty Optical Encoder is a compact heavy-duty encoder designed to exceed IP66/IP67 and NEMA 6 enclosure requirements. It is also available in stainless steel that exceeds NEMA 4X and NEMA 6P requirements and is ideal for stringent wash down environments, including those where high pressure steam or caustic chemicals are needed to meet regulatory requirements.

The HD20 features max. 440N Axial and Radial Bearings, -40° to +100°C temperature range and unique labyrinth double-sealed housing, and optional dual "redundant" outputs and is covered by a two-year warranty (one year for bearings). NorthStar's traditional quality, reliability and value are built-in to every HD20 encoder.

Also available in this series, is an Intrinsically Safe version certified to ATEX EEx ia IIB T4 when used with the appropriate IS Barrier. Accessory barriers can be supplied with the encoder.

### APPLICATIONS

The HD20 Harsh-Duty Optical Encoder is ideal for machine applications with corrosive environments that demand heavy washdown protection. This compact, special-duty encoder is designed to exceed IP66/IP67 and NEMA 6 enclosure requirements with a PPR range through 3600. ATEX certification is also available for intrinsically safe applications.

- Converting Machinery
- Material Handling
- Packaging Equipment
- Pickling Equipment
- Processing Equipment

#### Industries

Chemical, Food & Beverage, Oil & Gas, Paper, Steel and any other where a precise encoder is needed to operate in harsh environments.

### TECHNICAL DATA mechanical

Housing diameter	52.3 mm
Shaft diameter	9.52 mm / 10 mm (Solid shaft)
Flange (Mounting of housing)	Square flange
Protection class shaft input (EN 60529)	NEMA 4X or IP67
Protection class housing (EN 60529)	NEMA 4X or IP67

## Incremental

### TECHNICAL DATA mechanical (continued)

Shaft load axial / radial	max.: 440 N / 440 N
Max. speed	max. 6000 rpm
Bearing life	max. 5 x 10 <sup>11</sup> revs.
Torque	< 1.76 Ncm
Vibration resistance (DIN EN 60068-2-6)	200 m/s <sup>2</sup> (5 ... 2000 Hz)
Shock resistance (DIN EN 60068-2-27)	500 m/s <sup>2</sup> (11 ms)
Operating temperature	-40 °C ... +100 °C ATEX: -40 °C ... +80 °C
Material shaft	Stainless Steel
Material housing	Hard anodized Aluminum, Nickel
Weight	approx. 430 g
Connection	MS, radial M12-connector, radial Cable, radial

### TECHNICAL DATA electrical

Supply voltage	DC 5 - 26 V ATEX: DC 5 V ATEX: DC 7 - 26 V
Max. current w/o load	50 mA
Code	Incremental, optical
Max. pulse frequency	125 kHz
Phasing	Incremental signals (A leads B): A leads B by 90° for ccw shaft rotation viewing the shaft clamp end of the encoder
Pulse shape	Square wave

### ELECTRICAL CONNECTIONS 6, 7 & 10 Pin MS connector / Cable

Encoder Function	Cable 6 Pin Single Ended		Cable 7 Pin Single Ended		Cable 7 Pin Dif Line Drv w/o Idx		Cable 10 Pin Dif Line Drv w/ Idx		Cable Exit with Seal
	Pin	Wire Color	Pin	Wire Color	Pin	Wire Color	Pin	Wire Color	Wire Color
Sig. A	E	brown	A	brown	A	brown	A	brown	green
Sig. B	D	orange	B	orange	B	orange	B	orange	blue
Sig. Z	C	yellow	C	yellow	--	--	C	yellow	orange
Power +V	B	red	D	red	D	red	D	red	red
Com	A	black	F	black	F	black	F	black	black
Case	--	--	G	green	G	green	G	green	white
N/C	F	--	E	--	--	--	E	--	--
Sig. $\bar{A}$	--	--	--	--	C	brown/white	H	brown/white	violet
Sig. $\bar{B}$	--	--	--	--	E	orange/white	I	orange/white	brown
Sig. $\bar{Z}$	--	--	--	--	--	--	J	yellow/white	yellow

## Incremental

### DIMENSIONED DRAWINGS

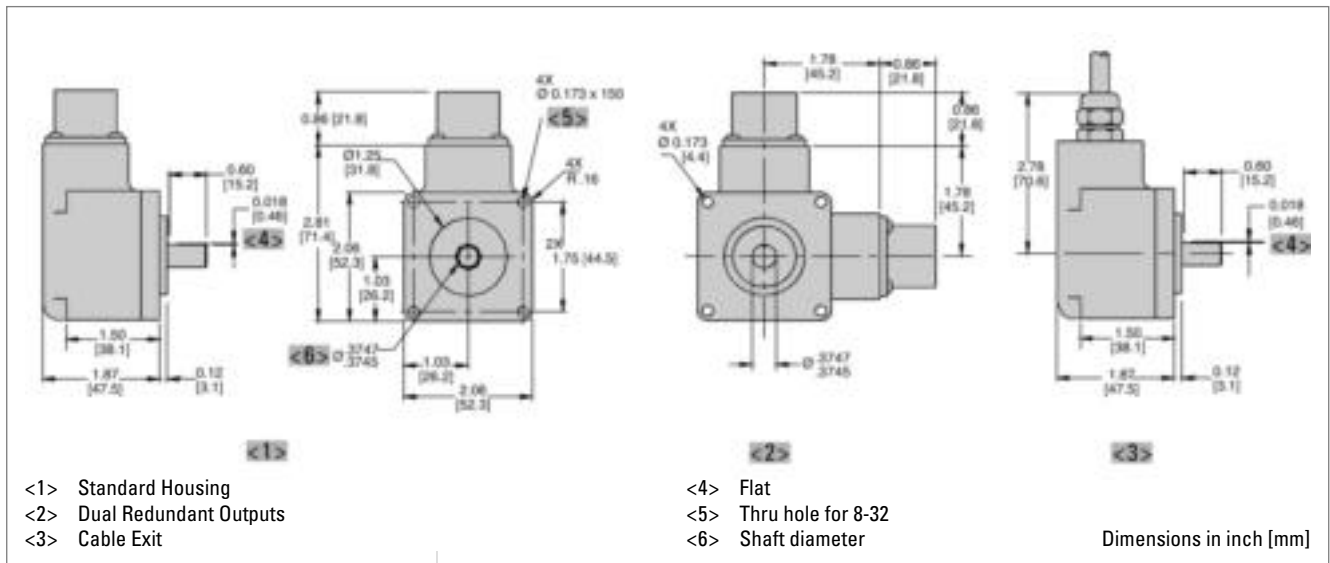



## Incremental

### ORDERING INFORMATION

Type	Format	Number of pulses	Shaft Ø	Output	Connection <sup>1</sup>	Housing, Tether, Options <sup>2,3,4,5</sup>
<input type="checkbox"/>	<input type="checkbox"/>	<input type="checkbox"/>	<input type="checkbox"/>	<input type="checkbox"/>	<input type="checkbox"/>	<input type="checkbox"/>
<b>HD20</b>	<b>1</b> Uni-directional <b>2</b> Bi-directional <b>3</b> Bi-directional with Index	<b>1 ... 3600</b>	<b>0</b> 9.52 mm (3/8") <b>4</b> 10 mm	<b>0</b> 5-26V in, 5-26V Open Collector out (7273) <b>2</b> 5-26V in, 5-26V Push-Pull out <b>3</b> 5-26V in, 5-26V Differential Line Driver out (7272) <b>4</b> 5-26V in, 5V Differential Line Driver out (7272) <b>F</b> 5-26V in, 5-26V Open Collector out (2222) <b>G</b> 5-26V in, 5-26V Open Collector out with 2.2 kΩ Pul-lups (2222)	<b>1</b> 6 pin connector <b>3</b> 7 pin connector <b>5</b> 10 pin connector <b>D</b> Sealed cable, 0.45 m <b>F</b> Sealed cable, 0.15 m <b>G</b> Sealed cable, 0.25 m <b>H</b> Sealed cable, 0.38 m	<b>0</b> No Options <b>1</b> Nickel Finish Housing <b>2</b> Stainless Steel Housing <b>3</b> Redundant Outputs (Dual Connector Housing) <b>4</b> Nickel Finish Housing with Redundant Outputs <b>5</b> Stainless Steel Housing with Redundant Outputs <b>A</b> Same as "0" with ATEX Typ 1 <b>B</b> Same as "1" with ATEX Typ 1 <b>C</b> Same as "2" with ATEX Typ 1 <b>D</b> Same as "3" with ATEX Typ 1 <b>E</b> Same as "4" with ATEX Typ 1 <b>F</b> Same as "5" with ATEX Typ 1 <b>G</b> Same as "0" with ATEX Typ 2 <b>H</b> Same as "1" with ATEX Typ 2 <b>I</b> Same as "2" with ATEX Typ 2 <b>J</b> Same as "3" with ATEX Typ 2 <b>K</b> Same as "4" with ATEX Typ 2 <b>L</b> Same as "5" with ATEX Typ 2 <b>M</b> Same as "0" with ATEX Typ 3 <b>N</b> Same as "1" with ATEX Typ 3 <b>O</b> Same as "2" with ATEX Typ 3 <b>P</b> Same as "3" with ATEX Typ 3 <b>Q</b> Same as "4" with ATEX Typ 3 <b>R</b> Same as "5" with ATEX Typ 3

<sup>1</sup> Output Code "3", "4" only available with Format Code "1", "2" and Connection Code "3" to "H" or with Format Code "3" and Connection Code "5" to "H"

<sup>2</sup> Available ATEX certified options:

ATEX Type 1: 5 V in, 5 V out

ATEX Type 2: 7-26V in, 7-26V out

ATEX Type 3: 7-26V in, 5V out

Note: When selecting ATEX models, ATEX voltages replace those shown in Output Code.

<sup>3</sup> Housing/Tether/Options Code "G" to "L" only available with Output Code "0" to "3", "F" or "G"

<sup>4</sup> Housing/Tether/Options Code "M" to "R" only available with Output Code "4"

<sup>5</sup> Note for Housing with redundant outputs: Simultaneous use of redundant outputs may void ATEX certification. Consult us for details.

## Incremental



- Single or Dual output
- Optional high current line driver
- ATEX Certification available for Intrinsically Safe application
- High Resolution Unbreakable Disk
- Industrial Duty Connector
- NEMA 4X / IP67 Rated
- Nickel or Stainless Steel Housing available

**HEAVY DUTY**

**NorthStar** CE

### NUMBER OF PULSES

0001 / 0025 / 0035 / 0040 / 0050 / 0060 / 0100 / 0120 / 0192 / 0200 / 0240 / 0250 / 0256 / 0300 / 0360 / 0500 / 0512 / 0600 / 0625 / 0720 / 0900 / 1000 / 1024 / 1200 / 1250 / 1440 / 1524 / 1600 / 1800 / 2000 / 2048 / 2500 / 2540 / 3000 / 3048 / 3600 / 4096 / 5000

### GENERAL INFORMATION

#### HARSH-DUTY OPTICAL ENCODER

The HD25 Harsh-Duty Optical Encoder is a compact heavy-duty encoder designed to exceed IP66/IP67 and NEMA 6 enclosure requirements. It is also available in stainless steel that exceeds NEMA 4X and NEMA 6P requirements and is ideal for stringent wash down environments, including those where high pressure steam or caustic chemicals are needed to meet regulatory requirements.

The HD25 features max. 440N Axial and Radial Bearings, -40° to +100°C temperature range and unique labyrinth double-sealed housing, and optional dual "redundant" outputs and is covered by a two-year warranty (one year for bearings). NorthStar's traditional quality, reliability and value are built-in to every HD25 encoder.

Also available in this series, is an Intrinsically Safe version certified to ATEX EEx ia IIB T4 when used with the appropriate IS Barrier. Accessory barriers can be supplied with the encoder.

### APPLICATIONS

The HD25 Harsh-Duty Optical Encoder is ideal for machine applications with corrosive environments that demand heavy washdown protection. This compact, special-duty encoder is designed to exceed IP66/IP67 and NEMA 6 enclosure requirements with a PPR range through 5000. ATEX certification is also available for intrinsically safe applications.

- Converting Machinery
- Material Handling
- Packaging Equipment
- Pickling Equipment
- Processing Equipment

#### Industries

Chemical, Food & Beverage, Oil & Gas, Paper, Steel and any other where a precise encoder is needed to operate in harsh environments.

### TECHNICAL DATA mechanical

Housing diameter	67.3 mm
Shaft diameter	3/8" / 10 mm (Solid shaft)
Flange (Mounting of housing)	Square flange
Protection class shaft input (EN 60529)	NEMA 4X or IP67

## Incremental

### TECHNICAL DATA mechanical (continued)

Protection class housing (EN 60529)	NEMA 4X or IP67
Shaft load axial / radial	max.: 440 N / 440 N
Max. speed	max. 6000 rpm
Bearing life	max. 5 x 10 <sup>11</sup> revs.
Torque	< 1.76 Ncm
Vibration resistance (DIN EN 60068-2-6)	200 m/s <sup>2</sup> (5 ... 2000 Hz)
Shock resistance (DIN EN 60068-2-27)	500 m/s <sup>2</sup> (11 msec)
Operating temperature	-40 °C ... +100 °C ATEX: -40 °C ... +80 °C
Material shaft	Stainless Steel
Material housing	Hard anodized Aluminum, Nickel, Stainless Steel
Weight	approx. 430 g
Connection	MS, radial M12-connector, radial

### TECHNICAL DATA electrical

Supply voltage	DC 5 - 26 V ATEX: DC 5 V ATEX: DC 7 - 26 V
Max. current w/o load	50 mA
Code	Incremental, optical
Max. pulse frequency	125 kHz
Phasing	Incremental signals (A leads B): A leads B by 90° for ccw shaft rotation viewing the shaft clamp end of the encoder
Pulse shape	Square wave

### ELECTRICAL CONNECTIONS 6, 7 & 10 Pin MS connector / Cable

Encoder Function	Cable 6 Pin Single Ended		Cable 7 Pin Single Ended		Cable 7 Pin Dif Line Drv w/o Idx		Cable 10 Pin Dif Line Drv w/ Idx		Cable Exit with Seal
	Pin	Wire Color	Pin	Wire Color	Pin	Wire Color	Pin	Wire Color	Wire Color
Sig. A	E	brown	A	brown	A	brown	A	brown	green
Sig. B	D	orange	B	orange	B	orange	B	orange	blue
Sig. Z	C	yellow	C	yellow	--	--	C	yellow	orange
Power +V	B	red	D	red	D	red	D	red	red
Com	A	black	F	black	F	black	F	black	black
Case	--	--	G	green	G	green	G	green	white
N/C	F	--	E	--	--	--	E	--	--
Sig. $\bar{A}$	--	--	--	--	C	brown/white	H	brown/white	violet
Sig. $\bar{B}$	--	--	--	--	E	orange/white	I	orange/white	brown
Sig. $\bar{Z}$	--	--	--	--	--	--	J	yellow/white	yellow

## Incremental

### DIMENSIONED DRAWINGS

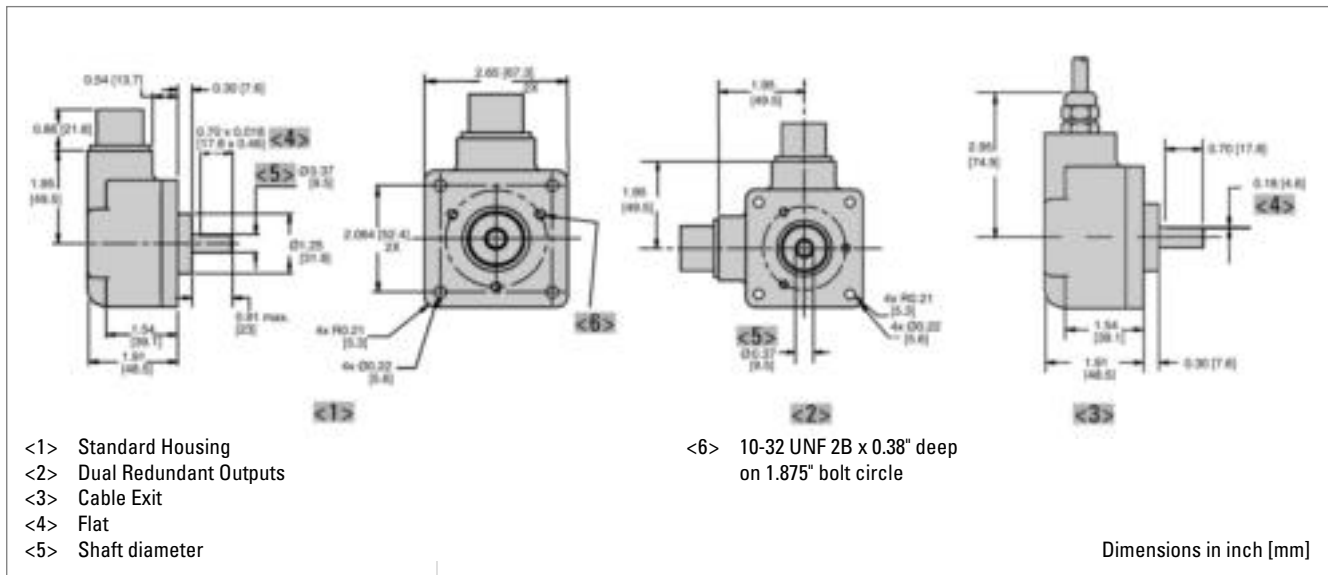

## Incremental

### ORDERING INFORMATION

Type	Format	Number of pulses	Shaft Ø	Output	Connection <sup>1</sup>	Housing, Tether, Options <sup>2,3,4,5</sup>
<input type="checkbox"/>	<input type="checkbox"/>	<input type="checkbox"/>	<input type="checkbox"/>	<input type="checkbox"/>	<input type="checkbox"/>	<input type="checkbox"/>
<b>HD25</b>	<b>1</b> Uni-directional <b>2</b> Bi-directional <b>3</b> Bi-directional with Index	<b>1 ... 5000</b>	<b>0</b> 9.52 mm (3/8") <b>4</b> 10 mm	<b>0</b> 5-26V in, 5-26V Open Collector out (7273) <b>2</b> 5-26V in, 5-26V Push-Pull out <b>3</b> 5-26V in, 5-26V Differential Line Driver out (7272) <b>4</b> 5-26V in, 5V Differential Line Driver out (7272) <b>6</b> 5-15V in, 5-15V Differential Line Driver out (4469) <b>F</b> 5-26V in, 5-26V Open Collector out (2222) <b>G</b> 5-26V in, 5-26V Open Collector out with 2.2 kΩ Pullups (2222)	<b>1</b> 6 pin connector <b>3</b> 7 pin connector <b>5</b> 10 pin connector <b>D</b> Sealed cable, 0.45 m <b>F</b> Sealed cable, 0.15 m <b>G</b> Sealed cable, 0.25 m <b>H</b> Sealed cable, 0.38 m	<b>0</b> No Options <b>1</b> Nickel Finish Housing <b>2</b> Stainless Steel Housing <b>3</b> Redundant Outputs (Dual Connector Housing) <b>4</b> Nickel Finish Housing with Redundant Outputs <b>5</b> Stainless Steel Housing with Redundant Outputs <b>A</b> Same as "0" with ATEX Typ 1 <b>B</b> Same as "1" with ATEX Typ 1 <b>C</b> Same as "2" with ATEX Typ 1 <b>D</b> Same as "3" with ATEX Typ 1 <b>E</b> Same as "4" with ATEX Typ 1 <b>F</b> Same as "5" with ATEX Typ 1 <b>G</b> Same as "0" with ATEX Typ 2 <b>H</b> Same as "1" with ATEX Typ 2 <b>I</b> Same as "2" with ATEX Typ 2 <b>J</b> Same as "3" with ATEX Typ 2 <b>K</b> Same as "4" with ATEX Typ 2 <b>L</b> Same as "5" with ATEX Typ 2 <b>M</b> Same as "0" with ATEX Typ 3 <b>N</b> Same as "1" with ATEX Typ 3 <b>O</b> Same as "2" with ATEX Typ 3 <b>P</b> Same as "3" with ATEX Typ 3 <b>Q</b> Same as "4" with ATEX Typ 3 <b>R</b> Same as "5" with ATEX Typ 3

<sup>1</sup> Output Code "3", "4", "6" only available with Format Code "1", "2" and Connection Code "3" to "H" or with Format Code "3" and Connection Code "5" to "H"

<sup>2</sup> Available ATEX certified options:

ATEX Type 1: 5 V in, 5 V out

ATEX Type 2: 7-26V in, 7-26V out

ATEX Type 3: 7-26V in, 5V out

Note: When selecting ATEX models, ATEX voltages replace those shown in Output Code.

<sup>3</sup> Housing/Tether/Options Code "G" to "L" only available with Output Code "0" to "3", "F" or "G"

<sup>4</sup> Housing/Tether/Options Code "M" to "R" only available with Output Code "4"

<sup>5</sup> Note for Housing with redundant outputs: Simultaneous use of redundant outputs may void ATEX certification. Consult us for details.

## Incremental



- Single or Dual output
- ATEX Certification available for Intrinsically Safe application
- High Resolution Unbreakable Disk
- Industrial Duty Connector
- NEMA 4X, 6 / IP66, 67 Rated
- Nickel or Stainless Steel Housing available

**HEAVY DUTY**

**NorthStar** CE

### NUMBER OF PULSES

0001 / 0024 / 0035 / 0040 / 0050 / 0060 / 0100 / 0120 / 0192 / 0200 / 0240 / 0250 / 0256 / 0300 / 0360 / 0500 / 0512 / 0600 / 0625 / 0720 / 1000 / 1024 / 1200 / 1250 / 1440 / 2000 / 2048 / 2500 / 2540 / 3000 / 3600

### GENERAL INFORMATION

#### HARSH-DUTY OPTICAL HUB SHAFT ENCODER

NorthStar's HSD25 Harsh-Duty Optical Hub Shaft Encoder accepts up to 0.75" diameter shafts and operates reliably from -40 to +100°C. The hard anodized finish encoder exceeds IP66/IP67 and NEMA 6 enclosure requirements.

This robust encoder is also available in Stainless Steel to meet NEMA 4x and 6P requirements and its sealed housing allows the Encoder to be operated when regulatory washdown and high pressure steam or caustic chemicals are required. Utilization of an advanced Opto ASIC with innovative packaging techniques enables the encoder to operate in high shock and vibration environments.

The HSD25 is also available in an Intrinsically Safe version certified to ATEX EEx ia IIB T4 when used with the appropriate IS barrier.

### APPLICATIONS

The HSD25 Harsh-Duty Optical Encoder features simple installation on motor or machine hub shafts. It is often mounted on the back of motors where encoder feedback is needed in harsh environment applications. Available housing options make it ideal use in corrosive environments that demand heavy washdown protection. ATEX certification is also available for intrinsically safe applications.

- Converting Machinery
- Material Handling
- Packaging Equipment
- Oil Field Exploration
- Processing Equipment

#### INDUSTRIES

Chemical, Food & Beverage, Oil & Gas, Paper, Steel and any other where a precise encoder is needed to operate in harsh environments.

### TECHNICAL DATA mechanical

Housing diameter	58.93 mm
Shaft diameter	3/8" / 10 mm / 12.7 mm / 5/8" / 3/4" (Hubshaft)
Flange (Mounting of housing)	Tether
Mounting of shaft	Front clamping ring
Protection class shaft input (EN 60529)	NEMA 4X or NEMA 6 IP66 or IP67

## Incremental

### TECHNICAL DATA mechanical (continued)

Protection class housing (EN 60529)	NEMA 4X or NEMA 6 IP66 or IP67
Bearing life	max. 5 x 10 <sup>11</sup> revs.
Torque	< 1.76 Ncm
Vibration resistance (DIN EN 60068-2-6)	200 m/s <sup>2</sup> (5 ... 2000 Hz)
Shock resistance (DIN EN 60068-2-27)	500 m/s <sup>2</sup> (11 sec)
Operating temperature	-40 °C ... +100 °C ATEX: -40 °C ... +80 °C
Material shaft	Stainless Steel
Material housing	Hard anodized Aluminum, Nickel, Stainless Steel
Weight	approx. 600 g
Connection	MS, radial M12-connector, radial Cable, radial

### TECHNICAL DATA electrical

Supply voltage	DC 5 - 26 V ATEX: DC 5 V ATEX: DC 7 - 26 V
Max. current w/o load	50 mA
Code	Incremental, optical
Max. pulse frequency	125 kHz
Phasing	Incremental signals (A leads B): A leads B by 90° for ccw shaft rotation viewing the shaft clamp end of the encoder
Pulse shape	Square wave

### ELECTRICAL CONNECTIONS 6, 7 & 10 Pin MS connector / Cable

Encoder Function	Cable 6 Pin Single Ended		Cable 7 Pin Single Ended		Cable 7 Pin Dif Line Drv w/o Idx		Cable 10 Pin Dif Line Drv w/ Idx		Cable 12 Pin CCW		Cable Exit with Seal
	Pin	Wire Color	Pin	Wire Color	Pin	Wire Color	Pin	Wire Color	Pin	Wire Color	Wire Color
Sig. A	E	brown	A	brown	A	brown	A	brown	5	brown	green
Sig. B	D	orange	B	orange	B	orange	B	orange	8	orange	blue
Sig. Z	C	yellow	C	yellow	--	--	C	yellow	3	yellow	orange
Power +V	B	red	D	red	D	red	D	red	12	red	red
Com	A	black	F	black	F	black	F	black	10	black	black
Case	--	--	G	green	G	green	G	green	9	--	white
N/C	F	--	E	--	--	--	E	--	7	--	--
Sig. $\bar{A}$	--	--	--	--	C	brown/white	H	brown/white	6	brown/white	violet
Sig. $\bar{B}$	--	--	--	--	E	orange/white	I	orange/white	1	orange/white	brown
Sig. $\bar{Z}$	--	--	--	--	--	--	J	yellow/white	4	yellow/white	yellow
0 Volt Sense	--	--	--	--	--	--	--	--	2	green	--
5 Volt Sense	--	--	--	--	--	--	--	--	11	black/white	--

## Incremental

### ELECTRICAL CONNECTIONS 5 & 8 Pin M12 Accessory Cable

Encoder Function	Cable 5 Pin Single Ended		Cable 8 Pin Single Ended		Cable 8 Pin Differential	
	Pin	Wire Color	Pin	Wire Color	Pin	Wire Color
Sig. A	4	black	1	brown	1	brown
Sig. B	2	white	4	orange	4	orange
Sig. Z	5	grey	6	yellow	6	yellow
Power +V	1	brown	2	red	2	red
Com	3	blue	7	black	7	black
Sig. $\bar{A}$					3	brown/white
Sig. $\bar{B}$					5	orange/white
Sig. $\bar{Z}$					8	yellow/white

### DIMENSIONED DRAWINGS

<1> Standard Housing  
 <2> 8-32 UNC x .28 deep on 2.000 bolt circl 4 places 90° apart  
 <3> Bore diameter  
 <4> Hub shaft cavity maximum depth  
 <5> Dual Redundant Outputs  
 <6> Cable Exit  
 <7> 4-40 x .25 deep 4 places - 90° apart  
 <8> 4-40 x .25 deep 90° apart  
 <9> Slotted Tether  
 □ Single Point Tether  
 ⌀ 0.172 [43.7] ON ⌀ 2.00 [50.8] B.C.

Dimensions in inch [mm]



## Incremental

### ORDERING INFORMATION

Type	Number of pulses	Shaft Ø	Format <sup>2 4</sup>	Output	Connection	Safety <sup>1 3</sup>	Housing, Tether, Options
<input type="checkbox"/>	<input type="checkbox"/>	<input type="checkbox"/>	<input type="checkbox"/>	<input type="checkbox"/>	<input type="checkbox"/>	<input type="checkbox"/>	<input type="checkbox"/>
<b>HSD25</b>	<b>1 ... 3600</b>	<b>4</b> 9.52 mm (3/8") <b>5</b> 10 mm <b>7</b> 12.7 mm (1/2") <b>8</b> 5/8" <b>C</b> 3/4"	<b>0</b> single ended, unidirectional (A) <b>1</b> single ended, bidirectional (AB) <b>2</b> single ended, bidirectional with index (ABZ) <b>3</b> differential, bidirectional (A→A B→B) <b>4</b> differential, bidirectional with index (A→A B→B Z→Z) <b>5</b> Dual isolated differential, bidirectional w/index (A→A B→B Z→Z)	<b>0</b> 5-26V in, 5-26V Open Collector out (7273) <b>2</b> 5-26V in, 5-26V Push-Pull out <b>3</b> 5-26V in, 5-26V Differential Line Driver out (7272) <b>4</b> 5-26V in, 5V Differential Line Driver out (7272) <b>F</b> 5-26V in, 5-26V Open Collector out (2222) <b>G</b> 5-26V in, 5-26V Open Collector out with 2.2 kΩ Pullups (2222)	<b>0</b> 6 pin connector <b>1</b> 7 pin connector <b>2</b> 10 pin connector <b>3</b> 12 pin connector <b>5</b> 6 pin connector plus mating connector <b>6</b> 7 pin connector plus mating connector <b>7</b> 10 pin connector plus mating connector <b>8</b> 12 pin connector plus mating connector <b>A</b> Cable 0,5 m <b>B</b> Cable 1 m <b>C</b> Cable 2 m <b>D</b> Cable 3m <b>F</b> 0.3 m cable with 10 pin connector plus mating connector <b>G</b> Cable, 0.3 m <b>H</b> M12 connector, 5 pole <b>J</b> M12 connector, 8 pole	<b>0</b> No ATEX <b>1</b> ATEX Type 1 Option <b>2</b> ATEX Type 2 Option <b>3</b> ATEX Type 3 Option	<b>0</b> Cast Aluminum Housing, Slotted Tether <b>1</b> Nickel Housing, slotted tether <b>2</b> Stainless Housing, slotted tether <b>3</b> Redundant Outputs (Dual Connector Housing), slotted tether <b>4</b> Nickel Housing, Redundant Outputs, slotted tether <b>5</b> Stainless Housing, Redundant Outputs, slotted-tether <b>C</b> Cast Aluminum Housing, Single-Point Tether Included (NEMA 4.5" C-face) <b>D</b> Nickel Housing, single-point tether <b>E</b> Stainless Housing, single-point tether <b>F</b> Redundant Outputs (Dual Connector Housing), single-point tether <b>G</b> Nickel Housing, Redundant Outputs, single-point tether <b>H</b> Stainless Housing, Redundant Outputs, single-point tether <b>6</b> Same as "0" but no tether <b>7</b> Same as "1" but no tether <b>8</b> Same as "2" but no tether <b>9</b> Same as "3" but no tether <b>A</b> Same as "4" but no tether <b>B</b> Same as "5" but no tether

<sup>1</sup> ATEX Type 1: 5 V in, 5 V out

ATEX Type 2: 7-26V in, 7-26V out

ATEX Type 3: 7-26V in, 5V out

<sup>2</sup> Format Code "3" only available with Output Code "3" or "4" resp. Housing/ Tether Code "0", "1", "2" or "6", "7", "8"

<sup>3</sup> Safety Code "2" only available with Output Code "4"

<sup>4</sup> Format Code "4" and Code "5" only available with Output Code "3" or "4" resp. Connection Code "A" to "G" and Housing/ Tether Code "0", "1", "2" or "6", "7", "8"

## Incremental

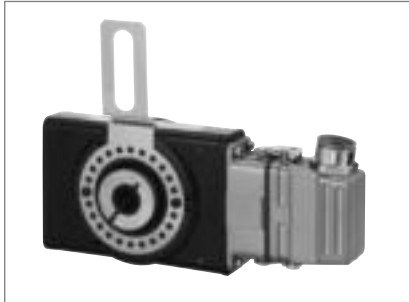

- Hollow Shaft design eliminates mounting bracket, flexible shaft coupling, and installation labor
- Bore is electrically and thermally insulated
- Single or Dual output - Optional high current line driver
- Choice of Stamped Metal or Swivel Rod Tether
- High Resolution Unbreakable Disk
- Industrial Duty Latching Connector
- NEMA 4 / IP65 Rated

**HEAVY DUTY**

**NorthStar** 

### NUMBER OF PULSES

0001 / 0002 / 0003 / 0005 / 0006 / 0007 / 0010 / 0012 / 0025 / 0050 / 0060 / 0064 / 0100 / 0120 / 0128 / 0180 / 0200 / 0240 / 0250 / 0300 / 0360 / 0400 / 0500 / 0512 / 0600 / 0720 / 0800 / 0900 / 1000 / 1024 / 1200 / 1270 / 1500 / 1800 / 2000 / 2048 / 2400 / 2500

### GENERAL INFORMATION

#### HEAVY DUTY SEALED HOLLOWSHAFT ENCODER

The NorthStar brand Series HSD35 Sealed Hollowshaft encoder is designed for easy installation on motor or machine shafts. Its hollowshaft design eliminates the need for a flexible shaft coupling, mounting bracket, flower pot, or flange adapter. This not only reduces the installation depth, but also lowers total cost.

The Series HSD35 Sealed Hollowshaft is equipped with an unbreakable disk that resists contamination and meets the demands of the most severe shock and vibration generating processes. Its floating shaft mount and spring tether eliminate bearing loads and flexible shaft couplings to eliminate wear and maintenance.

Series HSD35 has complete electrical protection from overvoltage, reverse voltage, and output short circuits. In addition, the Series HSD35 is not only electrically & thermally isolated, but also environmentally sealed with shaft seals at both ends.

### APPLICATIONS

The HSD35 sealed hollow shaft encoder is ideal for motor and machine applications at resolutions to 2500 PPR. Choice of stamped metal or swivel rod tether provide flexible mounting for a wide variety of installations

- Vector Motor and Drive Feedback
- Converting Machinery
- Packaging Equipment
- Paper Processing

#### INDUSTRIES

Manufacturing, Assembly, Material Handling and any other where a precise, reliable feedback signal is required.

### TECHNICAL DATA mechanical

Housing diameter	90.2 mm
Shaft diameter	6 mm / 8 mm / 10 mm / 12 mm / 15 mm / 25 mm / 28 mm / 31.75 mm (Through hollow shaft)
Flange (Mounting of housing)	Tether, Swivel rod
Mounting of shaft	Front clamping ring
Protection class shaft input (EN 60529)	IP65 or NEMA 4

## Incremental

### TECHNICAL DATA mechanical (continued)

Protection class housing (EN 60529)	IP65 or NEMA 4
Axial endplay of mounting shaft (hubshaft)	± 1.27 mm
Radial runout of mating shaft (hubshaft)	± 0.63 mm
Max. speed	max. 3600 rpm
Bearing life	80 000 hours at 3600 rpm; 128 000 hours at 1800 rpm
Torque	3.53 Ncm (max.)
Vibration resistance (DIN EN 60068-2-6)	200 m/s <sup>2</sup> (5 ... 2000 Hz)
Shock resistance (DIN EN 60068-2-27)	500 m/s <sup>2</sup> (11 ms)
Operating temperature	-40 °C ... +70 °C Option: 0 °C ... +100 °C
Storage temperature	-40 °C ... +90 °C
Weight	max. 870 g
Connection	10 pin connector

### TECHNICAL DATA electrical

Supply voltage	DC 4,5 - 26 V
Max. current w/o load	100 mA
Code	Incremental, optical
Max. pulse frequency	100 kHz
Phasing	Incremental signals (A leads B): A leads B by 90° for ccw shaft rotation viewing the shaft clamp end of the encoder
Pulse shape	Square wave

## Incremental

### DIMENSIONED DRAWINGS

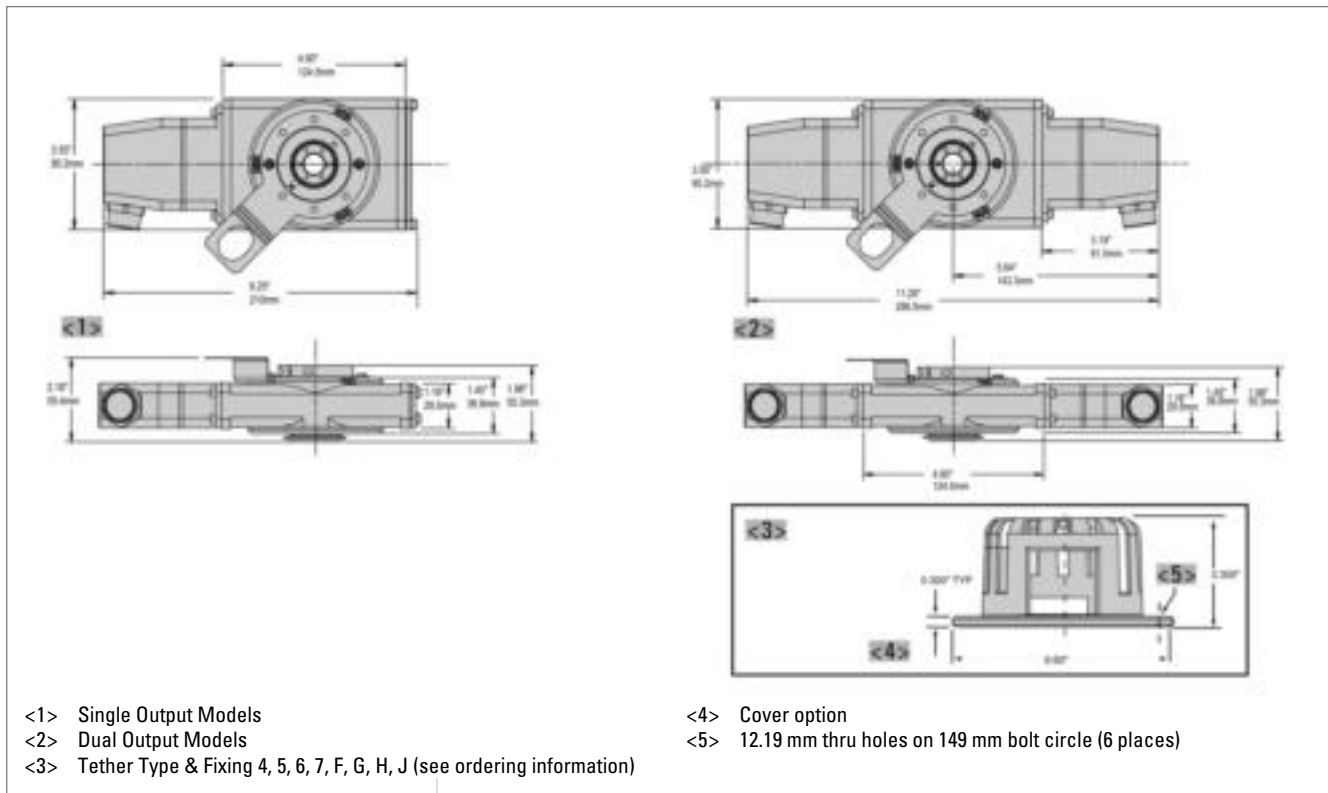

## Incremental

### ORDERING INFORMATION

Type	Number of pulses	Shaft Ø	Tether Type & Fixing <sup>1,2</sup>	Format <sup>3</sup>	Output	Seal	Housing, Tether, Options
<input type="checkbox"/>	<input type="checkbox"/>	<input type="checkbox"/>	<input type="checkbox"/>	<input type="checkbox"/>	<input type="checkbox"/>	<input type="checkbox"/>	<input type="checkbox"/>
<b>HSD35</b>	<b>1 ... 2500</b>	<b>0</b> 6 mm <b>1</b> 1/4" <b>2</b> 5/16" <b>3</b> 8 mm <b>4</b> 9.52 mm (3/8") <b>5</b> 10 mm <b>6</b> 12 mm <b>7</b> 12.7 mm (1/2") <b>8</b> 5/8" <b>9</b> 15 mm <b>A</b> 16 mm <b>B</b> 19 mm <b>C</b> 3/4" <b>D</b> 20 mm <b>E</b> 7/8" <b>F</b> 24 mm <b>G</b> 1" <b>H</b> 1-1/8" <b>J</b> 14 mm <b>K</b> 18 mm <b>M</b> 25 mm <b>N</b> 28 mm <b>P</b> 1-1/4"	<b>A</b> Standard Tether <b>C</b> 180C Tether <b>E</b> 180C Tether with protective guard <b>B</b> 56C Tether <b>D</b> 56C Tether with protective guard <b>0</b> None - customer supplied <b>H</b> Same as 'A' w/ dual cover kit <b>F</b> Same as 'A', w/ cover kit <b>J</b> Same as 'B' w/ dual cover kit <b>G</b> Same as 'B', w/ cover kit	<b>0</b> single ended, unidirectional (A) <b>1</b> single ended, bidirectional (AB) <b>2</b> single ended, bidirectional with index (ABZ) <b>3</b> differential, bidirectional (A-A B-B) <b>4</b> differential, bidirectional with index (A-A B-B Z-Z) <b>5</b> Dual isolated differential, bidirectional w/index (A-A B-B Z-Z)	<b>0</b> 5 - 26 V in, 5 - 26 V Open Collector out <b>0</b> 5-26V in, 5-26V Open Collector out (7273) <b>2</b> 5 - 26 V in, 5 - 26 V Push pull out <b>1</b> 5-26V in, 5-26V open collector out with 2.2kΩ pullups <b>2</b> 5-26V in, 5-26V Push-Pull out <b>3</b> 5 - 26 V in, 5 - 26 V Differential Line Driver out <b>4</b> 5-26V in, 5V Differential Line Driver out <b>A</b> same as '3' but up to +100°C <b>B</b> same as '4' but up to +100°C	<b>1</b> Rugged Shaft Seals <b>0</b> Standard Shaft Seals	<b>Blank</b> None <b>D</b> LED Output Indicator

<sup>1</sup> Tether Type & Fixing Code "F" or Code "G" only available with Format Code "0" to "4"

<sup>2</sup> Housing Tether & Fixing Code "H" or Code "J" only available with Format Code "5"

<sup>3</sup> Format Code "3" to Code "5" only available with Output Code "3" to Code "6" and Code "A" resp. "B"

## Incremental



- Single or Dual Output
- Double-Sealed Housing
- ATEX Certification for Intrinsically Safe Applications
- High Resolution Unbreakable Disk
- Electrically and Thermally Isolated
- Industrial Duty Connector
- NEMA 4X, 6 / IP66, 67 Rated
- Rugged Cast-Aluminum Housing
- Stainless Steel Housing Available

**HEAVY DUTY**

**NorthStar** 

### NUMBER OF PULSES

0015 / 0032 / 0100 / 0200 / 0240 / 0250 / 0500 / 0512 / 0600 / 1000 / 1024 / 1200 / 2000 / 2048 / 2500 / 4000 / 5000

### GENERAL INFORMATION

#### EXTREME HEAVY DUTY HOLLOWSHAFT ENCODER

NorthStar's HSD37 Extreme Duty Industrial Hollowshaft Encoder accepts up to 1" diameter shafts and operates reliably from -40 to +100°C. Its Hard Anodized finish enclosure exceeds IP66/IP67 and NEMA 6 enclosure requirements.

This robust encoder features a double-sealed housing that allows application where regulatory washdown or caustic chemicals are present. Utilization of an advanced Opto ASIC with innovative packaging techniques enables the encoder to operate in high shock and vibration environments.

It is also available in an Intrinsically Safe version, certified to ATEX EEx ia IIB T4, when used with the appropriate IS Barrier.

### APPLICATIONS

The HSD37 extreme duty encoder features simple installation on motor or machine shafts. It is often mounted on the back of motors where encoder feedback is needed in harsh environment applications. It is ideal for use in environments that demand heavy washdown protection.

- Converting Machinery
- Material Handling
- Packaging Equipment
- Processing Equipment

#### Industries

Chemical, Food & Beverage, Oil & Gas, Paper, Steel and any other where a precise encoder is needed to operate in harsh environments.

### TECHNICAL DATA mechanical

Housing diameter	95.25 mm
Shaft diameter	12 mm / 1/2" / 15 mm / 5/8" / 16 mm / 3/4" / 0.875" (Through hollow shaft)
Flange (Mounting of housing)	Tether
Mounting of shaft	Front clamping ring
Protection class shaft input (EN 60529)	NEMA 4X or NEMA 6 IP66 or IP67

## Incremental

### TECHNICAL DATA mechanical (continued)

Protection class housing (EN 60529)	NEMA 4X or NEMA 6 IP66 or IP67
Bearing life	31,75 mm max. 5 x 10 <sup>11</sup> revs.
Torque	2.8 Ncm
Vibration resistance (DIN EN 60068-2-6)	200 m/s <sup>2</sup> (5 ... 2000 Hz)
Shock resistance (DIN EN 60068-2-27)	500 m/s <sup>2</sup> (11 msec)
Operating temperature	-40 °C ... +100 °C ATEX: -40 °C ... +80 °C
Material shaft	Aluminum
Material housing	Hard anodized Aluminum, Stainless Steel
Weight	approx. 1000 g
Connection	MS, radial Cable, radial with M12 connector

### TECHNICAL DATA electrical

Supply voltage	DC 5 - 26 V
Max. current w/o load	50 mA
Code	Incremental, optical
Max. pulse frequency	125 kHz
Phasing	Incremental signals (A leads B): A leads B by 90° for ccw shaft rotation viewing the shaft clamp end of the encoder
Pulse shape	Square wave

### ELECTRICAL CONNECTIONS 6, 7 & 10 Pin MS connector / Cable

Encoder Function	Cable 6 Pin Single Ended		Cable 7 Pin Single Ended		Cable 7 Pin Dif Line Drv w/o Idx		Cable 10 Pin Dif Line Drv w/ Idx		Cable Exit with Seal
	Pin	Wire Color	Pin	Wire Color	Pin	Wire Color	Pin	Wire Color	Wire Color
Sig. A	E	brown	A	brown	A	brown	A	brown	green
Sig. B	D	orange	B	orange	B	orange	B	orange	blue
Sig. Z	C	yellow	C	yellow	--	--	C	yellow	orange
Power +V	B	red	D	red	D	red	D	red	red
Com	A	black	F	black	F	black	F	black	black
Case	--	--	G	green	G	green	G	green	white
N/C	F	--	E	--	--	--	E	--	--
Sig. $\bar{A}$	--	--	--	--	C	brown/white	H	brown/white	violet
Sig. $\bar{B}$	--	--	--	--	E	orange/white	I	orange/white	brown
Sig. $\bar{Z}$	--	--	--	--	--	--	J	yellow/white	yellow

## Incremental

### ELECTRICAL CONNECTIONS 5 & 8 Pin M12 Accessory Cable

Encoder Function	Cable 5 Pin Single Ended		Cable 8 Pin Single Ended		Cable 8 Pin Differential	
	Pin	Wire Color	Pin	Wire Color	Pin	Wire Color
Sig. A	4	black	1	brown	1	brown
Sig. B	2	white	4	orange	4	orange
Sig. Z	5	grey	6	yellow	6	yellow
Power +V	1	brown	2	red	2	red
Com	3	blue	7	black	7	black
Sig. $\bar{A}$					3	brown/white
Sig. $\bar{B}$					5	orange/white
Sig. $\bar{Z}$					8	yellow/white

### DIMENSIONED DRAWINGS

The drawings include:

- <1>**: Front view of the encoder housing with dimensions for mounting holes and overall size.
- <2>**: Side view of the encoder housing showing the mounting flange and dimensions.
- <3>**: Top view of the encoder housing showing the mounting holes and dimensions.
- <4>**: Front view of the encoder housing with two cables attached, showing dimensions for cable placement.
- <5>**: Front view of the encoder housing with two cables attached, showing dimensions for cable placement.
- <6>**: Side view of the encoder housing with a pigtail cable and MS connector.
- <7>**: Side view of the encoder housing with a single point tether.
- <8>**: Side view of the encoder housing with a slotted tether.

Dimensions in inch [mm]

- <1> 10-32 UNF x .38 deep on a  $\varnothing$  3.000 bolt circle
- <2> 10-32 clamp screw
- <3> on 3.00 [76.20] bolt circle
- <4> 10-32 UNF x .38 deep on a  $\varnothing$  3.000 bolt circle
- <5> Redundant Version
- <6> Pigtail with MS Connector (K Option)
- <7> Single Point Tether
- <8> Slotted Tether



## Incremental

### ORDERING INFORMATION

Type	Number of pulses	Shaft Ø	Format 4,5	Output	Connection 6	Safety 1,2,3	Housing, Tether, Options
<input type="checkbox"/>	<input type="checkbox"/>	<input type="checkbox"/>	<input type="checkbox"/>	<input type="checkbox"/>	<input type="checkbox"/>	<input type="checkbox"/>	<input type="checkbox"/>
<b>HSD37</b>	<b>15 ... 5000</b>	<b>6</b> 12 mm <b>7</b> 12.7 mm (1/2") <b>8</b> 5/8" <b>9</b> 15 mm <b>A</b> 16 mm <b>C</b> 3/4" <b>E</b> 7/8" <b>G</b> 1"	<b>0</b> single ended, unidirectional (A) <b>1</b> single ended, bidirectional (AB) <b>2</b> single ended, bidirectional with index (ABZ) <b>3</b> differential, bidirectional (A→A B→B) <b>4</b> differential, bidirectional with index (A→A B→B Z→Z)	<b>0</b> 5-26V in, 5-26V Open Collector out (7273) <b>2</b> 5-26V in, 5-26V Push-Pull out <b>3</b> 5-26V in, 5-26V Differential Line Driver out (7272) <b>4</b> 5-26V in, 5V Differential Line Driver out (7272)	<b>0</b> 6 pin connector <b>1</b> 7 pin connector <b>2</b> 10 pin connector <b>5</b> 6 pin connector plus mating connector <b>6</b> 7 pin connector plus mating connector <b>7</b> 10 pin connector plus mating connector <b>A</b> Cable, 0.5 m <b>H</b> M12 connector, 5 pole <b>J</b> M12 connector, 8 pole <b>K</b> 0.5 m cable with 10 pin in-line connector <b>L</b> Cable, 0.91 m <b>M</b> Cable, 1.52 m <b>N</b> Cable, 3.05 m	<b>0</b> No ATEX <b>1</b> ATEX Type 1 Option <b>2</b> ATEX Type 2 Option <b>3</b> ATEX Type 3 Option	<b>0</b> Cast Aluminum Housing, Slotted Tether <b>2</b> Stainless Housing, slotted tether <b>3</b> Redundant Outputs (Dual Connector Housing), slotted tether <b>5</b> Stainless Housing, Redundant Outputs, slotted-tether <b>C</b> Cast Aluminum Housing, Single-Point Tether Included (NEMA 4.5" C-face) <b>E</b> Stainless Housing, single-point tether <b>F</b> Redundant Outputs (Dual Connector Housing), single-point tether <b>H</b> Stainless Housing, Redundant Outputs, single-point tether <b>6</b> Same as "0" but no tether <b>8</b> Same as "2" but no tether <b>9</b> Same as "3" but no tether <b>B</b> Same as "5" but no tether

<sup>1</sup> ATEX Type 1: 5 V in, 5 V out

ATEX Type 2: 7-26V in, 7-26V out

ATEX Type 3: 7-26V in, 5V out

<sup>2</sup> Safety Code "2" not available in combination with Output Code "4"

<sup>3</sup> Safety Code "3" only available with Output Code "4"

<sup>4</sup> Format Code "3" only available with Code "3" or "4"

<sup>5</sup> Format Code "4" only available with Output Code "3" or "4" resp. Connection Code "2", "7", "J", "K", "L", "M", "N" or "A"

<sup>6</sup> Connection Code "H" only available with Code "0" or "2"

## Incremental



- Double-Sealed Housing
- High Resolution Unbreakable Disk
- Electrically and Thermally Isolated
- Industrial Duty Connector
- NEMA 4X, 6 / IP66 or IP67 Rated
- Rugged Cast-Aluminum Housing

**HEAVY DUTY**

**NorthStar** 

### NUMBER OF PULSES

0015 / 0032 / 0100 / 0200 / 0240 / 0250 / 0500 / 0512 / 0600 / 1000 / 1024 / 1200 / 2000 / 2048 / 2500 / 4000 / 5000

### GENERAL INFORMATION

#### EXTREME HEAVY DUTY HOLLOWSHAFT ENCODER

NorthStar's HSD38 Extreme Duty Industrial Hollowshaft Encoder accepts up to 1" (25,4 mm) diameter shafts and operates reliably from -40 to +100°C. Its Hard Anodized finish enclosure exceeds IP66/IP67 and NEMA 6 enclosure requirements.

This robust encoder features a double-sealed housing that allows application where regulatory washdown and high pressure steam or caustic chemicals are present. Utilization of an advanced Opto ASIC with innovative packaging techniques enables the encoder to operate in high shock and vibration environments.

### APPLICATIONS

The HSD38 extreme duty encoder features simple installation on motor or machine shafts. It is often mounted on the back of motors where encoder feedback is needed in harsh environment applications. It is ideal for use in environments that demand heavy washdown protection.

- Converting Machinery
- Material Handling
- Packaging Equipment
- Processing Equipment

#### Industries

Chemical, Food & Beverage, Paper, Steel and any other where a precise encoder is needed to operate in harsh environments.

### TECHNICAL DATA mechanical

Housing diameter	96.52 mm
Shaft diameter	12 mm / 15 mm / 1/2" / 5/8" / 16 mm / 3/4" / 0.875" (Hubshaft)
Flange (Mounting of housing)	Tether
Mounting of shaft	Front clamping ring
Protection class shaft input (EN 60529)	NEMA 4X or NEMA 6 IP66 or IP67
Protection class housing (EN 60529)	NEMA 4X or NEMA 6 IP66 or IP67
Bearing life	max. 5 x 10 <sup>11</sup> revs.
Torque	< 2.8 Ncm

## Incremental

### TECHNICAL DATA mechanical (continued)

Vibration resistance (DIN EN 60068-2-6)	200 m/s <sup>2</sup> (5 ... 2000 Hz)
Shock resistance (DIN EN 60068-2-27)	500 m/s <sup>2</sup> (11 msec)
Operating temperature	-40 °C ... +100 °C
Storage temperature	-40 °C ... +100 °C
Material shaft	Aluminum
Material housing	Hard anodized Aluminum
Weight	approx. 800 g
Connection	MS, radial Cable, radial with M12 connector

### TECHNICAL DATA electrical

Supply voltage	DC 5 - 26 V
Max. current w/o load	50 mA
Code	Incremental, optical
Max. pulse frequency	125 kHz
Phasing	Incremental signals (A leads B): A leads B by 90° for ccw shaft rotation viewing the shaft clamp end of the encoder
Pulse shape	Square wave

### ELECTRICAL CONNECTIONS 6, 7 & 10 Pin MS connector / Cable

Encoder Function	Cable 6 Pin Single Ended		Cable 7 Pin Single Ended		Cable 7 Pin Dif Line Drv w/o Idx		Cable 10 Pin Dif Line Drv w/ Idx		Cable Exit with Seal
	Pin	Wire Color	Pin	Wire Color	Pin	Wire Color	Pin	Wire Color	Wire Color
Sig. A	E	brown	A	brown	A	brown	A	brown	green
Sig. B	D	orange	B	orange	B	orange	B	orange	blue
Sig. Z	C	yellow	C	yellow	--	--	C	yellow	orange
Power +V	B	red	D	red	D	red	D	red	red
Com	A	black	F	black	F	black	F	black	black
Case	--	--	G	green	G	green	G	green	white
N/C	F	--	E	--	--	--	E	--	--
Sig $\bar{A}$	--	--	--	--	C	brown/white	H	brown/white	violet
Sig $\bar{B}$	--	--	--	--	E	orange/white	I	orange/white	brown
Sig $\bar{Z}$	--	--	--	--	--	--	J	yellow/white	yellow

## Incremental

### ELECTRICAL CONNECTIONS 5 & 8 Pin M12 Accessory Cable

Encoder Function	Cable 5 Pin Single Ended		Cable 8 Pin Single Ended		Cable 8 Pin Differential	
	Pin	Wire Color	Pin	Wire Color	Pin	Wire Color
Sig. A	4	black	1	brown	1	brown
Sig. B	2	white	4	orange	4	orange
Sig. Z	5	grey	6	yellow	6	yellow
Power +V	1	brown	2	red	2	red
Com	3	blue	7	black	7	black
Sig. $\bar{A}$					3	brown/white
Sig. $\bar{B}$					5	orange/white
Sig. $\bar{Z}$					8	yellow/white

### DIMENSIONED DRAWINGS

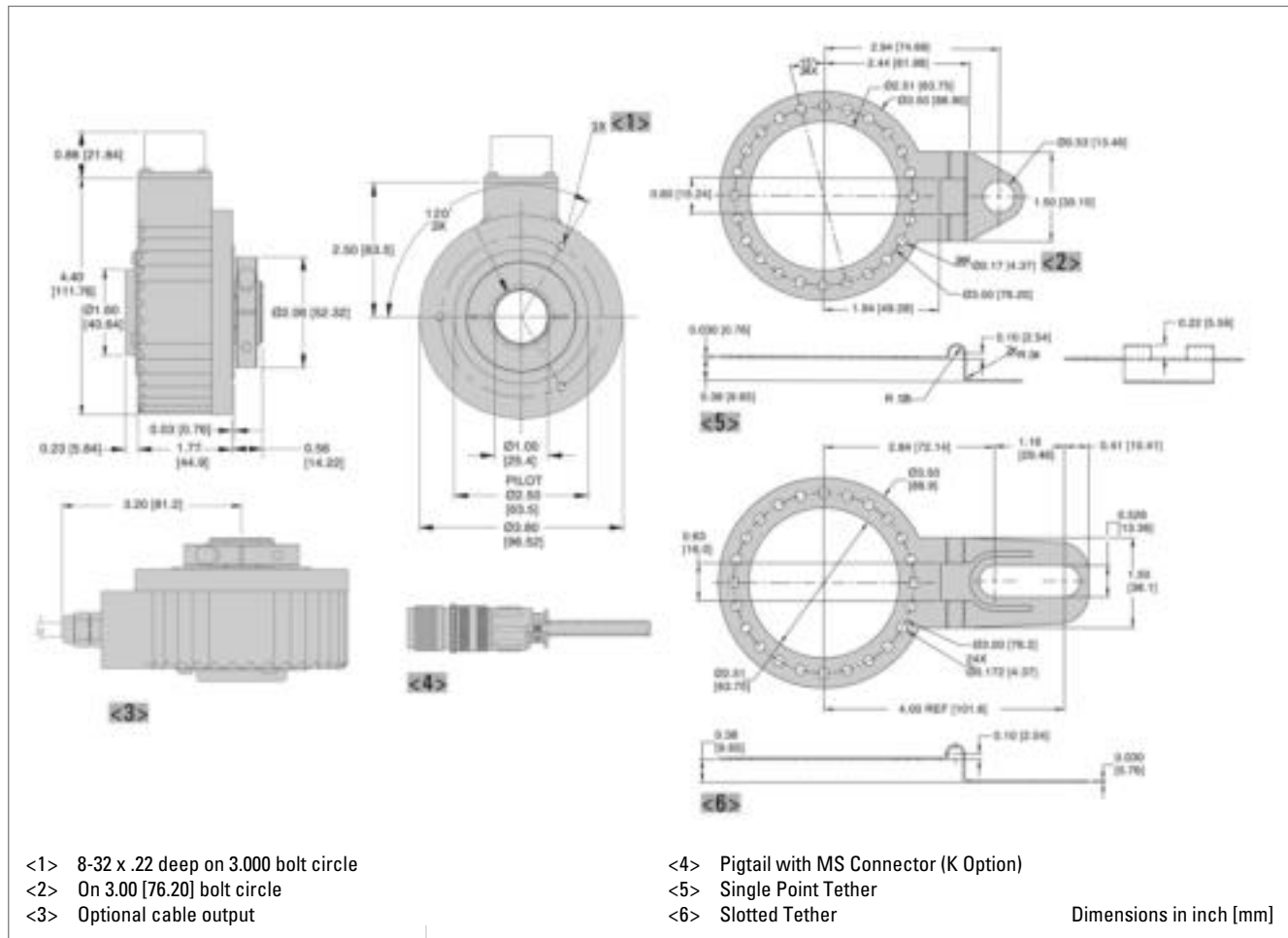

## Incremental

### ORDERING INFORMATION

Type	Number of pulses	Shaft Ø	Format	Output	Connection	Safety	Housing, Tether, Options
<input type="checkbox"/>	<input type="checkbox"/>	<input type="checkbox"/>	<input type="checkbox"/>	<input type="checkbox"/>	<input type="checkbox"/>	<input type="checkbox"/>	<input type="checkbox"/>
<b>HSD38</b>	<b>15 ... 5000</b>	<b>6</b> 12 mm <b>7</b> 12.7 mm (1/2") <b>8</b> 5/8" <b>9</b> 15 mm <b>A</b> 16 mm <b>C</b> 3/4" <b>E</b> 7/8" <b>G</b> 1"	<b>0</b> single ended, unidirectional (A) <b>1</b> single ended, bidirectional (AB) <b>2</b> single ended, bidirectional with index (ABZ) <b>3</b> differential, bidirectional (A↔A B↔B) <b>4</b> differential, bidirectional with index (A↔A B↔B Z↔Z)	<b>0</b> 5-26V in, 5-26V Open Collector out (7273) <b>2</b> 5-26V in, 5-26V Push-Pull out <b>3</b> 5-26V in, 5-26V Differential Line Driver out (7272) <b>4</b> 5-26V in, 5V Differential Line Driver out (7272)	<b>0</b> 6 pin connector <b>1</b> 7 pin connector <b>2</b> 10 pin connector <b>5</b> 6 pin connector plus mating connector <b>6</b> 7 pin connector plus mating connector <b>7</b> 10 pin connector plus mating connector <b>A</b> Cable 0,5 m <b>G</b> Cable, 0.3 m <b>H</b> M12 connector, 5 pole <b>J</b> M12 connector, 8 pole <b>K</b> 0.5 m cable with 10 pin in-line connector	<b>0</b> Reserved for Future Options	<b>0</b> Cast Aluminum Housing, Slotted Tether <b>C</b> Cast Aluminum Housing, Single-Point Tether Included (NEMA 4.5" C-face) <b>6</b> Cast Aluminum Housing, No Tether

## Incremental



- Single or Dual output - NAMUR available
- Well suited for DrawWorks/ oil field application
- ATEX Certification available for Intrinsically Safe application
- High Resolution Unbreakable Disk
- Industrial Duty Connector
- NEMA 4X / IP67 Rated
- Nickel or Stainless Steel Housing available
- Option: removable shaft with thread
- Option: redundant output

**HEAVY DUTY**

**NorthStar** CE

### NUMBER OF PULSES

0015 / 0032 / 0100 / 0200 / 0240 / 0250 / 0500 / 0512 / 0600 / 1000 / 1024 / 1200 / 2000 / 2048 / 4000 / 5000

### GENERAL INFORMATION

#### HARSH- DUTY OPTICAL ENCODER - DRAWWORKS

The DWD38 Harsh-Duty Optical Encoder is an Industrial Hollow Shaft design that operates reliably from -40 to +100°C. Its Hard Anodized finish exceeds IP66/IP67 and NEMA 6 enclosure requirements.

The DWD38 is a preferred choice as a DrawWorks encoder by the Oil Field industry and is also commonly used in high shock and vibration environments such as Food Processing, Material Handling and Packaging Equipment applications.

Extremely robust, the DWD38 encoder is also available in Stainless Steel to meet NEMA 4x and 6P requirements. A unique labyrinth double-sealed housing allows operation when regulatory washdown and high pressure steam or caustic chemicals are required.

It is also available in an Intrinsically Safe version, certified to ATEX EEx ia IIB T4, when used with the appropriate IS Barrier.

### APPLICATIONS

The DWD38 Harsh-Duty Optical Encoder is ideal for DrawWorks application and corrosive environments that demand heavy washdown protection. This compact, special-duty encoder is designed to exceed IP66/IP67 and NEMA 6 enclosure requirements with a PPR range through 5000. ATEX certification is also available for intrinsically safe applications.

- DrawWorks and other Oilfield
- Converting Machinery
- Material Handling
- Packaging Equipment
- Pickling Equipment
- Processing Equipment

#### INDUSTRIES

Chemical, Food & Beverage, Oil & Gas, Paper, Steel and any other where a precise encoder is needed to operate in very harsh environments.

### TECHNICAL DATA mechanical

Housing diameter	3.75"
Flange (Mounting of housing)	Synchro flange

## Incremental

### TECHNICAL DATA mechanical (continued)

Protection class shaft input (EN 60529)	IP67 or NEMA 6
Protection class housing (EN 60529)	IP67 or NEMA 6
Shaft load axial / radial	Max.: 100 N / 100 N
Bearing life	max. 5 x 10 <sup>11</sup> revs.
Vibration resistance (DIN EN 60068-2-6)	200 m/s <sup>2</sup> (5 to 2000 Hz)
Shock resistance (DIN EN 60068-2-27)	500 m/s <sup>2</sup> (11 msec)
Operating temperature	-40 °C ... +100 °C ATEX: -40 °C ... +80 °C
Storage temperature	-40 °C ... +100 °C
Material shaft	Stainless Steel
Material housing	Hard anodized Aluminum, Stainless Steel
Connection	MS, radial Cable, radial

### TECHNICAL DATA electrical

Supply voltage	DC 5 - 26 V ATEX: DC 5 V ATEX: DC 5 - 26 V
Max. current w/o load	50 mA
Code	Incremental, optical
Max. pulse frequency	125 kHz
Standard output versions	RS422: A, B, N, $\bar{A}$ , $\bar{B}$ , $\bar{N}$ NPN-O.C.: A, B, N Push-pull: A, B, N

### ELECTRICAL CONNECTIONS 6, 7 & 10 Pin MS connector / Cable

Encoder Function	Cable 6 Pin Single Ended		Cable 7 Pin Single Ended		Cable 7 Pin Dif Line Drv w/o Idx		Cable 10 Pin Dif Line Drv w/ Idx		Cable Exit with Seal
	Pin	Wire Color	Pin	Wire Color	Pin	Wire Color	Pin	Wire Color	Wire Color
Sig. A	E	brown	A	brown	A	brown	A	brown	green
Sig. B	D	orange	B	orange	B	orange	B	orange	blue
Sig. Z	C	yellow	C	yellow	--	--	C	yellow	orange
Power +V	B	red	D	red	D	red	D	red	red
Com	A	black	F	black	F	black	F	black	black
Case	--	--	G	green	G	green	G	green	white
N/C	F	--	E	--	--	--	E	--	--
Sig. $\bar{A}$	--	--	--	--	C	brown/white	H	brown/white	violet
Sig. $\bar{B}$	--	--	--	--	E	orange/white	I	orange/white	brown
Sig. $\bar{Z}$	--	--	--	--	--	--	J	yellow/white	yellow

## Incremental

### DIMENSIONED DRAWINGS

<1>                      <2>                      <3>

<1> With Convertable Shaft  
 <2> With Non-Convertible Shaft  
 <3> Redundant Version  
 <4> 10-32 UNF x .38 deep on Ø 3.000 bolt circle  
 <5> 5/8-18 UNF male thread

<6> 1"-14 UNS female internal thread O-ring sealed  
 <7> 1"-14 UNS male thread  
 <8> Removable hollow shaft extension included with encoder

Dimensions in inch [mm]



## Incremental

### ORDERING INFORMATION

Type	Format	Number of pulses	Shaft Ø	Output <sup>1,2</sup>	Connection	Housing, Tether, Options <sup>3,4,5,6</sup>
<input type="checkbox"/>	<input type="checkbox"/>	<input type="checkbox"/>	<input type="checkbox"/>	<input type="checkbox"/>	<input type="checkbox"/>	<input type="checkbox"/>
<b>DWD38</b>	<b>1</b> Uni-directional <b>2</b> Bi-directional <b>3</b> Bi-directional with Index	<b>15 ... 5000</b>	<b>0</b> 1"-14 UNS x 5/8" - 18 UNF Threaded Shaft <b>1</b> 1"-14 UNS Threaded Shaft	<b>0</b> 5-26V in, 5-26V Open Collector out (7273) <b>2</b> 5-26V in, 5-26V Push-Pull out <b>3</b> 5-26V in, 5-26V Differential Line Driver out (7272) <b>4</b> 5-26V in, 5V Differential Line Driver out (7272) <b>F</b> 5-26V in, 5-26V Open Collector out (2222) <b>G</b> 5-26V in, 5-26V Open Collector out with 2.2 kΩ Pullups (2222) <b>N</b> NAMUR 15 mA Maximum	<b>1</b> 6 pin connector <b>3</b> 7 pin connector <b>5</b> 10 pin connector <b>D</b> Sealed cable, 0.45 m <b>F</b> Sealed cable, 0.15 m <b>G</b> Sealed cable, 0.25 m <b>H</b> Sealed cable, 0.38 m	<b>0</b> No Options <b>1</b> Nickel Finish Housing <b>2</b> Stainless Steel Housing <b>3</b> Redundant Outputs (Dual Connector Housing) <b>4</b> Nickel Finish Housing with Redundant Outputs <b>5</b> Stainless Steel Housing with Redundant Outputs <b>A</b> Same as "0" with ATEX Typ 1 <b>B</b> Same as "1" with ATEX Typ 1 <b>C</b> Same as "2" with ATEX Typ 1 <b>D</b> Same as "3" with ATEX Typ 1 <b>E</b> Same as "4" with ATEX Typ 1 <b>F</b> Same as "5" with ATEX Typ 1 <b>G</b> Same as "0" with ATEX Typ 2 <b>H</b> Same as "1" with ATEX Typ 2 <b>I</b> Same as "2" with ATEX Typ 2 <b>J</b> Same as "3" with ATEX Typ 2 <b>K</b> Same as "4" with ATEX Typ 2 <b>L</b> Same as "5" with ATEX Typ 2 <b>M</b> Same as "0" with ATEX Typ 3 <b>N</b> Same as "1" with ATEX Typ 3 <b>O</b> Same as "2" with ATEX Typ 3 <b>P</b> Same as "3" with ATEX Typ 3 <b>Q</b> Same as "4" with ATEX Typ 3 <b>R</b> Same as "5" with ATEX Typ 3

<sup>1</sup> Output Code "3", "4" only available with Format Code "1", "2" and Connection Code "3" to "H" or with Format Code "3" and Connection Code "5" to "H"

<sup>2</sup> Output Code "N" only available with "Number of pulses" Code "0015"

<sup>3</sup> Available ATEX certified options:

ATEX Type 1: 5 V in, 5 V out

ATEX Type 2: 7-26V in, 7-26V out

ATEX Type 3: 7-26V in, 5V out

Note: When selecting ATEX models, ATEX voltages replace those shown in Output Code.

<sup>4</sup> Housing/Tether/Options Code "G" to "L" only available with Output Code "0" to "3", "F" or "G"

<sup>5</sup> Housing/Tether/Options Code "M" to "R" only available with Output Code "4"

<sup>6</sup> Note for Housing with redundant outputs: Simultaneous use of redundant outputs may void ATEX certification. Consult us for details.

## Absolute

## BiSS / SSI

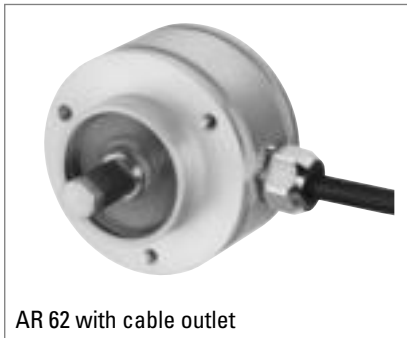

AR 62 with cable outlet



AR 62 with M12 connector

- Singleturn 12 Bit Resolution
- 300 N axial and radial load
- 200 g shock resistance
- 20 g vibrations resistance
- Submersible: Protection class up to IP69k
- High temperature range: -40 ... +100°C
- Compact design: 32 mm mounting depth
- Option: Stainless steel housing
- Option: Control inputs Preset and Direction

ACURO®-XR

HEAVY DUTY

BISS  
INTERFACE

SSI

CE



### GENERAL INFORMATION

### ACURO-XR - THE ROBUST ENCODER FOR ALL ENVIRONMENTAL CONDITIONS!

The special features of the new ACURO-XR series not only comprise its particularly rugged enclosure, but also generously dimensioned, rigid ball-bearings. Capable of withstanding even high axial and radial loads on its shaft axis, this encoder type easily achieves a mechanical life of  $10^9$  rotations at a permanent radial load of 200 N and simultaneously, an axial load of 200N.

The newly designed ACURO-XR makes a difference. It easily withstands highest accelerations, extreme climatic fluctuations and even underwater operation. In this way, our rugged absolute encoder is ideally suitable for applications in wind farms, marine or utility vehicle applications, as well as for use in presses or wood and stone processing machinery: applications where high resistance to harsh environments and maximum reliability are required at the same time.

The AR62 is electrically compatible with standard encoders and operates with the magnetic technology. Available interfaces are SSI, BiSS, CANopen and Analogue (0 ... 10 V or 4 ... 20 mA).

With an installed depth of only 32 mm, this encoder is the most compact type in its class. Valuable space has been saved – to the benefit of the overall machinery design.

### APPLICATIONS

Fields of application that clearly unfold the benefits of ACURO-XR:

- Construction machinery
- Utility vehicles / trucks
- Gantry cranes
- Marine equipment
- Offshore plants
- Wind power plants
- Commercial solar plants
- Food & Beverage Industry
- Filling plants
- Presses
- Your individual application

## Absolute

## BiSS / SSI

### TECHNICAL DATA mechanical

Housing diameter	58 mm
Mounting depth	32 mm
Shaft diameter	10 mm / 12 mm (Solid shaft)
Flange (Mounting of housing)	Synchro clamping flange
Protection class shaft input (EN 60529)	IP67 or IP69k
Protection class housing (EN 60529)	IP67 or IP69k
Shaft load axial / radial	max.: 300 N / 300 N
Max. speed	max. 5000 rpm
Vibration resistance (DIN EN 60068-2-6)	200 m/s <sup>2</sup>
Shock resistance (DIN EN 60068-2-27)	2000 m/s <sup>2</sup> (6 ms)
Operating temperature	-40 °C ... +100 °C
Connection	Cable, radial M12-connector, radial

### TECHNICAL DATA electrical

Supply voltage	DC 10-30 V
Max. current w/o load	50 mA (24 V)
EMC	EN 61326 Class A
Resolution singleturn	12 Bit
Output code	Gray
Repeatability	±0,2°
Control inputs <sup>1</sup>	Preset, Direction

<sup>1</sup> Preset, Direction optional available

### ELECTRICAL CONNECTIONS Cable

Color cable	Signal
yellow	Clock
pink	Data
green	$\overline{\text{Clock}}$
grey	$\overline{\text{Data}}$
white	UB
brown	0 V
Screen	Screen

### DIMENSIONED DRAWINGS

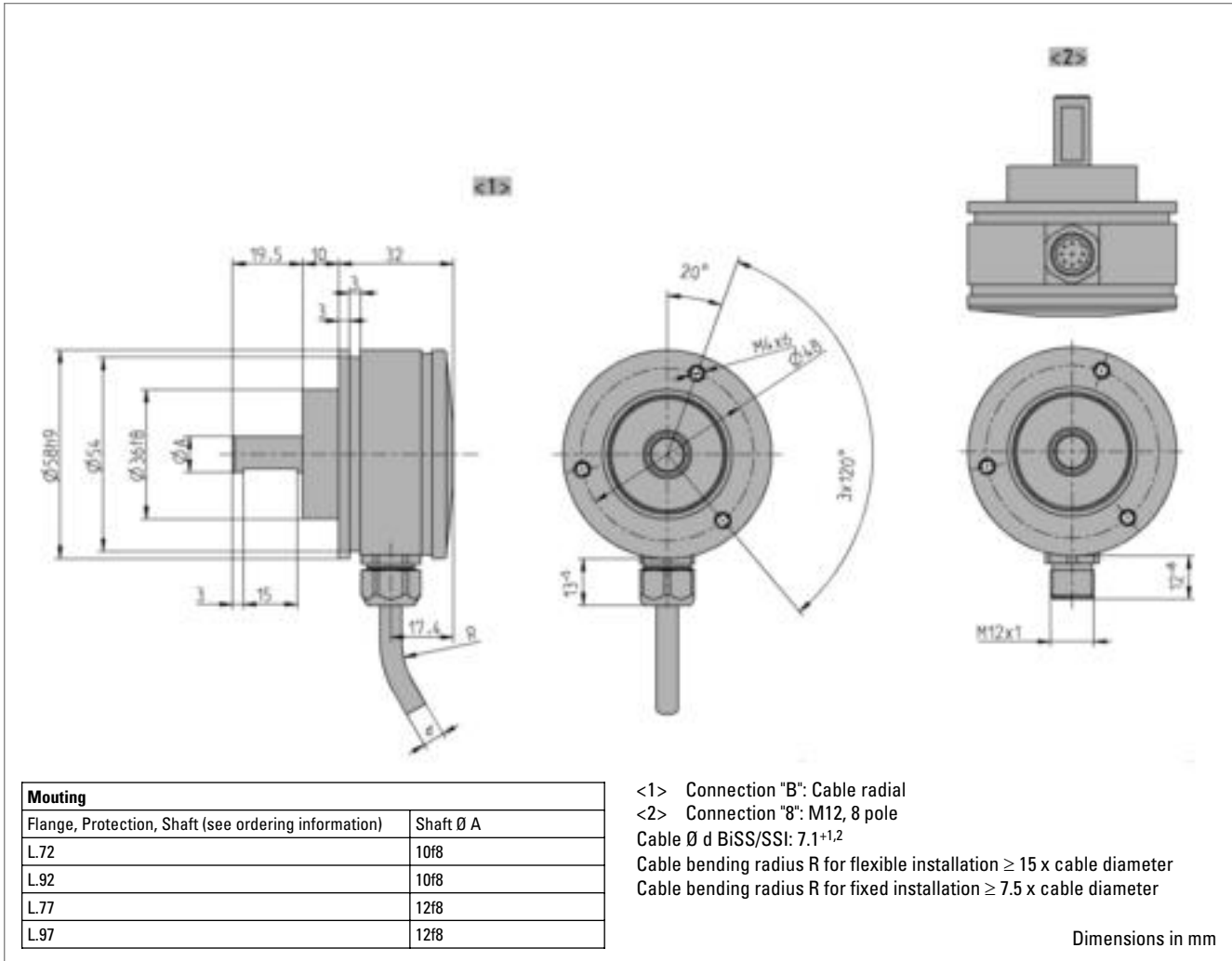

### ORDERING INFORMATION

Type	Resolution	Supply voltage	Flange, Protection, Shaft	Interface	Connection <sup>1,2</sup>
<input type="text"/>	<input type="text"/>	<input type="text"/>	<input type="text"/>	<input type="text"/>	<input type="text"/>
<b>AR62</b> Aluminum <b>AR63</b> Stainless Steel	<b>0012</b> 12 Bit ST	<b>E</b> DC 10 - 30 V	<b>L.72</b> Synchro clamping, IP67, 10 mm <b>L.77</b> Synchro clamping, IP67, 12 mm <b>L.92</b> Synchro clamping, IP69k, 10 mm <b>L.97</b> Synchro clamping, IP69K, 12 mm	<b>SG</b> SSI Gray <b>BG</b> BiSS Gray	<b>B</b> Cable, radial <b>8</b> M12 connector, 8 pole, radial

<sup>1</sup> M12 connector not available with Stainless Steel housing

<sup>2</sup> M12 connector not available with IP69K

**Absolute****BiSS / SSI****ORDERING INFORMATION**  
**Selection of cable length**

Versions with cable outlet (connection A, B, E or F) are available with various lengths of cable. To order your desired cable length, please add the respective code to the end of your ordering code. Further cable lengths on request.

<b>Code</b>	<b>Cable length</b>
without code	1.5 m
-D0	3 m
-F0	5 m
-K0	10 m
-P0	15 m
-U0	20 m
-V0	25 m

## Absolute

## CANopen

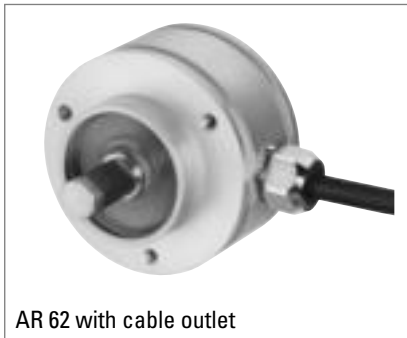

AR 62 with cable outlet



AR 62 with M12 connector

### GENERAL INFORMATION

- Singleturn 12 Bit Resolution
- 300 N axial and radial load
- 200 g shock resistance
- 20 g vibration resistance
- Submersible: Protection class up to IP69K
- High temperature range: -40 ... +100°C
- Compact design: 32 mm mounting depth
- Option: Stainless steel housing

ACURO®-XR

HEAVY DUTY

CANopen

CE



### ACURO-XR - THE ROBUST ENCODER FOR ALL ENVIRONMENTAL CONDITIONS!

The special features of the new ACURO-XR series not only comprise its particularly rugged enclosure, but also generously dimensioned, rigid ball-bearings. Capable of withstanding even high axial and radial loads on its shaft axis, this encoder type easily achieves a mechanical life of  $10^9$  rotations at a permanent radial load of 200 N and simultaneously, an axial load of 200N.

The newly designed ACURO-XR makes a difference. It easily withstands highest accelerations, extreme climatic fluctuations and even underwater operation. In this way, our rugged absolute encoder is ideally suitable for applications in wind farms, marine or utility vehicle applications, as well as for use in presses or wood and stone processing machinery: applications where high resistance to harsh environments and maximum reliability are required at the same time.

The AR62 is electrically compatible with standard encoders and operates with the magnetic technology. Available interfaces are SSI, BiSS, CANopen and Analogue (0 ... 10 V or 4 ... 20 mA).

With an installed depth of only 32 mm, this encoder is the most compact type in its class. Valuable space has been saved – to the benefit of the overall machinery design.

### APPLICATIONS

Fields of application that clearly unfold the benefits of ACURO-XR:

- Construction machinery
- Utility vehicles / trucks
- Gantry cranes
- Marine equipment
- Offshore plants
- Wind power plants
- Commercial solar plants
- Food & Beverage Industry
- Filling plants
- Presses
- Your individual application

## Absolute

## CANopen

### TECHNICAL DATA mechanical

Housing diameter	58 mm
Mounting depth	32 mm
Shaft diameter	10 mm / 12 mm (Solid shaft)
Flange (Mounting of housing)	Synchro clamping flange
Protection class shaft input (EN 60529)	IP67 or IP69k
Protection class housing (EN 60529)	IP67 or IP69k
Shaft load axial / radial	max.: 300 N / 300 N
Max. speed	max. 5000 rpm
Vibration resistance (DIN EN 60068-2-6)	200 m/s <sup>2</sup>
Shock resistance (DIN EN 60068-2-27)	2000 m/s <sup>2</sup> (6 ms)
Operating temperature	-40 °C ... +100 °C
Connection	Cable, radial M12-connector, radial

### TECHNICAL DATA electrical

Supply voltage	DC 10-30 V
Max. current w/o load	220 mA
EMC	EN 61326 Class A
Resolution singleturn	12 Bit
Output code	Binary
Interface	CAN High-Speed according to ISO/DIS 11898
Profile/ protocol	CANopen according to DS 301 with profile DSP 406, programmable encoder according class C2
Repeatability	±0,2°
Parametrization	Scaling, Preset, Offset, Direction
Integrated special functions	Speed, Acceleration, Limit values

### ELECTRICAL CONNECTIONS Cable

Color cable	Cable pairs	Signal
yellow	Pair 1	CAN in+
green		CAN in-
pink	Pair 2	CAN out+
grey		CAN out-
blue		n.c.
red		n.c.
white	Pair 3	UB
brown		0 V
Screen	Screen	Screen

### DIMENSIONED DRAWINGS

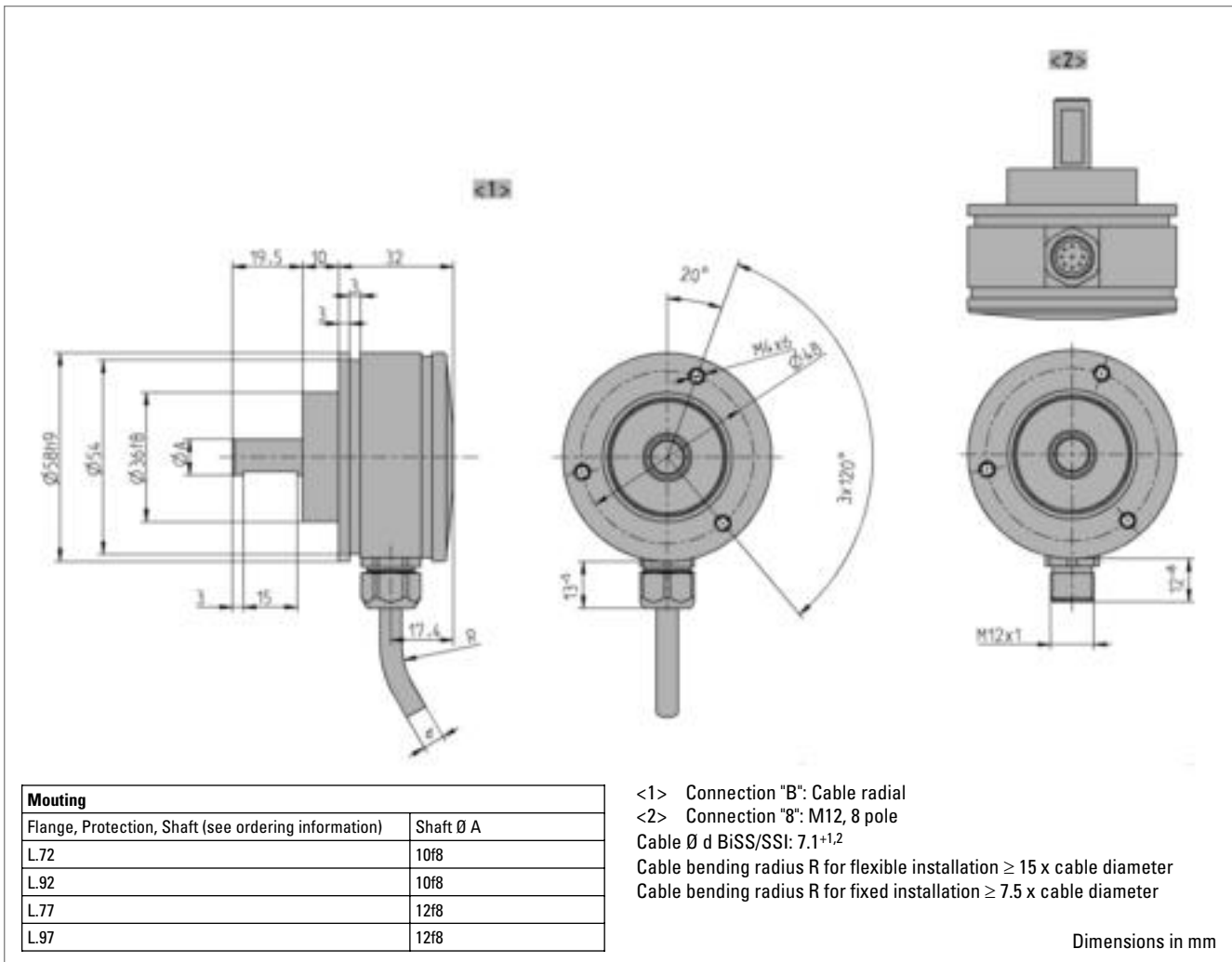

### ORDERING INFORMATION

Type	Resolution	Supply voltage	Flange, Protection, Shaft	Interface	Connection <sup>1,2</sup>
<input type="checkbox"/>	<input type="checkbox"/>	<input type="checkbox"/>	<input type="checkbox"/>	<input type="checkbox"/>	<input type="checkbox"/>
<b>AR62</b> Aluminum <b>AR63</b> Stainless Steel	<b>0012</b> 12 Bit ST	<b>E</b> DC 10 - 30 V	<b>L.72</b> Synchro clamping, IP67, 10 mm <b>L.77</b> Synchro clamping, IP67, 12 mm <b>L.92</b> Synchro clamping, IP69k, 10 mm <b>L.97</b> Synchro clamping, IP69K, 12 mm	<b>OL</b> CANopen	<b>B</b> Cable, radial <b>8</b> M12 connector, 8 pole, radial

<sup>1</sup> M12 connector not available with Stainless steel housing (AR63)

<sup>2</sup> M12 connector not available with IP69K



## Absolute

## CANopen

### ORDERING INFORMATION Selection of cable length

Versions with cable outlet (connection A, B, E or F) are available with various lengths of cable. To order your desired cable length, please add the respective code to the end of your ordering code. Further cable lengths on request.

Code	Cable length
without code	1.5 m
-D0	3 m
-F0	5 m
-K0	10 m
-P0	15 m
-U0	20 m
-V0	25 m

## Absolute

## Analogue

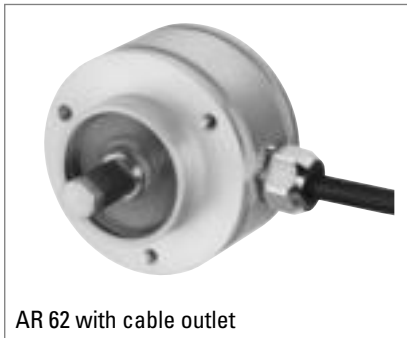

AR 62 with cable outlet



AR 62 with M12 connector

### GENERAL INFORMATION

- Singleturn 12 Bit Resolution
- 300 N axial and radial load
- 200 g shock resistance
- 20 g vibration resistance
- Submersible: Protection class up to IP69k
- High temperature range: -40 ... +100°C
- Compact design: 32 mm mounting depth
- Option: Stainless steel housing
- Option: Control inputs Preset and Direction

ACURO®-XR

HEAVY DUTY



### APPLICATIONS

### ACURO-XR - THE ROBUST ENCODER FOR ALL ENVIRONMENTAL CONDITIONS!

The special features of the new ACURO-XR series not only comprise its particularly rugged enclosure, but also generously dimensioned, rigid ball-bearings. Capable of withstanding even high axial and radial loads on its shaft axis, this encoder type easily achieves a mechanical life of  $10^9$  rotations at a permanent radial load of 200 N and simultaneously, an axial load of 200N.

The newly designed ACURO-XR makes a difference. It easily withstands highest accelerations, extreme climatic fluctuations and even underwater operation. In this way, our rugged absolute encoder is ideally suitable for applications in wind farms, marine or utility vehicle applications, as well as for use in presses or wood and stone processing machinery: applications where high resistance to harsh environments and maximum reliability are required at the same time.

The AR62 is electrically compatible with standard encoders and operates with the magnetic technology. Available interfaces are SSI, BiSS, CANopen and Analogue (0 ... 10 V or 4 ... 20 mA).

With an installed depth of only 32 mm, this encoder is the most compact type in its class. Valuable space has been saved – to the benefit of the overall machinery design.

Fields of application that clearly unfold the benefits of ACURO-XR:

- Construction machinery
- Utility vehicles / trucks
- Gantry cranes
- Marine equipment
- Offshore plants
- Wind power plants
- Commercial solar plants
- Food & Beverage Industry
- Filling plants
- Presses
- Your individual application

## Absolute

## Analogue

### TECHNICAL DATA mechanical

Housing diameter	58 mm
Mounting depth	32 mm
Shaft diameter	10 mm / 12 mm (Solid shaft)
Flange (Mounting of housing)	Synchro clamping flange
Protection class shaft input (EN 60529)	IP67 or IP69k
Protection class housing (EN 60529)	IP67 or IP69k
Shaft load axial / radial	max.: 300 N / 300 N
Max. speed	max. 5000 rpm
Vibration resistance (DIN EN 60068-2-6)	200 m/s <sup>2</sup>
Shock resistance (DIN EN 60068-2-27)	2000 m/s <sup>2</sup> (6 ms)
Operating temperature	-40 °C ... +100 °C
Connection	Cable, radial M12-connector, radial

### TECHNICAL DATA electrical

Supply voltage	DC 17 - 30 V
Max. current w/o load	50 mA (24 V)
EMC	EN 61326 Class A
Resolution singleturn	12 Bit
Interface	Analogue: 0 ... 10 V, Analogue: 4 ... 20 mA
Tolerance	Voltage output: 0 V: + 100 mV; 10 V: +/- 100 mV Current output: 4 mA ± 100 µA typ; 20 mA ± 100 µA typ
Load resistor	Voltage output: max. 2 kΩ Current output: max. 600 Ω (Output current max. 5 mA)
Repeatability	±0,2°
Control inputs <sup>1</sup>	Direction, Preset
Updating of values	updating every millisec (continuously)

<sup>1</sup> Preset, Direction optional available

### ELECTRICAL CONNECTIONS Analogue

Color Cable	Cable pairs	Signal
pink	Pair 1	0 ... 10 V (Voltage output max. 5 mA)
blau		0 ... 20 mA or 4 ... 20 mA (current output)
grey		AGND
red		preset (set to 0)
white	Pair 2	UB
brown		0 V
yellow <sup>1</sup>	Pair 3	Diagnostic 1
green <sup>1</sup>		Diagnostic 2
Screen	Screen	Screen

<sup>1</sup> Diagnostic signals only for service purposes. The cable wires have to be isolated.

### DIMENSIONED DRAWINGS

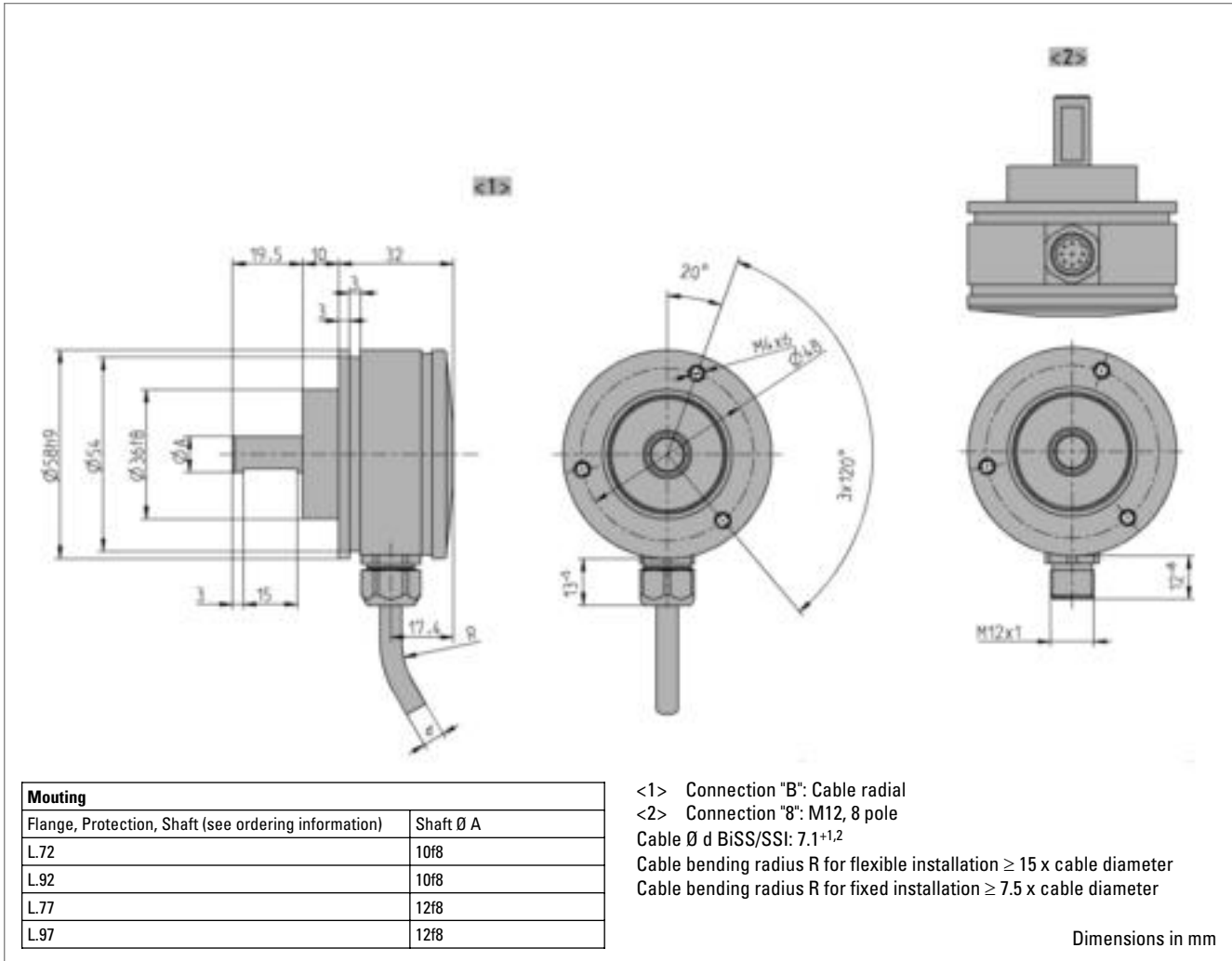

### ORDERING INFORMATION

Type	Resolution	Supply voltage	Flange, Protection, Shaft	Interface	Connection <sup>1,2</sup>
<input type="checkbox"/>	<input type="checkbox"/>	<input type="checkbox"/>	<input type="checkbox"/>	<input type="checkbox"/>	<input type="checkbox"/>
<b>AR62</b> Aluminum <b>AR63</b> Stainless Steel	<b>0012</b> 12 Bit ST	<b>F</b> DC 17 - 30 V	<b>L.72</b> Synchro clamping, IP67, 10 mm <b>L.77</b> Synchro clamping, IP67, 12 mm <b>L.92</b> Synchro clamping, IP69k, 10 mm <b>L.97</b> Synchro clamping, IP69K, 12 mm	<b>AV</b> Analogue 0 ... 10 V <b>A0</b> Analogue 0 ... 20 mA <b>A4</b> Analogue 4 ... 20 mA	<b>B</b> Cable, radial <b>8</b> M12 connector, 8 pole, radial

<sup>1</sup> M12 connector not available with Stainless Steel housing (AR63)

<sup>2</sup> M12 connector is not available with IP69K

**Absolute****Analogue****ORDERING INFORMATION**  
**Selection of cable length**

Versions with cable outlet (connection A, B, E or F) are available with various lengths of cable. To order your desired cable length, please add the respective code to the end of your ordering code. Further cable lengths on request.

<b>Code</b>	<b>Cable length</b>
without code	1.5 m
-D0	3 m
-F0	5 m
-K0	10 m
-P0	15 m
-U0	20 m
-V0	25 m

## Standard Industrial Types Incremental



Incremental encoders are sensors capable of generating signals in response to rotary movement. In conjunction with mechanical conversion devices, such as rack-and-pinions, measuring wheels or spindles, incremental shaft encoders can also be used to measure linear movement. The shaft encoder generates a signal for each incremental change in position.

With the optical transformation, a line-coded disc made of metal, plastic or glass and positioned on a rotary bearing interrupts the infra red light ray emitted by gallium arsenid sender diode. The number of lines determines the resolution, i.e. the measuring points within a revolution. The interruptions of the light ray are sensed by the receptor element and electronically processed. The information is then made available as a rectangular signal at the encoder output.

### Examples for typical applications of incremental encoders:

- Door closing devices for trains
- Desktop robots
- Lens grinding machines
- Plotters
- Testing machines  
for optical waveguides
- Scattering machines
- Tampon printing machines
- Ultrasonic welding
- Screwing machines
- Labelling machines
- x/y indication
- Analysis devices
- Drilling machines
- Mixing machines

## Incremental

## Solid Shaft



- Miniature encoder for industrial use
- Low current consumption
- High noise interference immunity
- Cable lengths of up to 100 m
- Suitable for high pulse frequencies
- High protection class
- Applications: CNC machines, manipulators, motors, medical technology, textile machines



### NUMBER OF PULSES

5 / 10 / 20 / 25 / 30 / 50 / 60 / 100 / 120 / 200 / 250 / 256 / 288 / 300 / 360 / 400 / **500** / **512** / 600 / 720 / 900 / **1000** / 1024 / 1250 / 1500

Other number of pulses on request

Preferably available versions are printed in bold type.

### TECHNICAL DATA mechanical

Housing diameter	30 mm
Shaft diameter	5 mm (Solid shaft)
Flange (Mounting of housing)	Synchro flange, Pilot flange
Protection class shaft input (EN 60529)	IP64
Protection class housing (EN 60529)	IP64
Shaft load axial / radial	5 N / 10 N
Max. speed	max. 10 000 rpm
Torque	≤ 0.2 Ncm
Moment of inertia	approx. 0.8 gcm <sup>2</sup>
Vibration resistance (DIN EN 60068-2-6)	100 m/s <sup>2</sup> (10 ... 2000 Hz)
Shock resistance (DIN EN 60068-2-27)	1000 m/s <sup>2</sup> (6 ms)
Operating temperature	-10 °C ... +70 °C
Storage temperature	-25 °C ... +85 °C
Material housing	Aluminum
Weight	approx. 60 g
Connection	Cable, axial or radial M16 (Binder), axial

### TECHNICAL DATA electrical

General design	as per DIN VDE 0160, protection class III, contamination level 2, overvoltage class II
Supply voltage	RS422 + Alarm (R), RS422 + Sense (T): DC 5 V ±10 % Push-pull (K): ± 10% DC 5 V or DC 10 - 30 V
Max. current w/o load	40 mA (DC 5 V), 60 mA (DC 10 V), 30 mA (DC 24 V)
Max. pulse frequency	RS422: 300 kHz Push-pull: 200 kHz
Standard output versions <sup>1,2</sup>	RS422 + Alarm (R): A, B, N, $\bar{A}$ , $\bar{B}$ , $\bar{N}$ , $\overline{\text{Alarm}}$ RS422 + Sense (T): A, B, N, $\bar{A}$ , $\bar{B}$ , $\bar{N}$ , Sense Push-pull (K): A, B, N, $\overline{\text{Alarm}}$
Pulse width error	± max. 25° electrical
Number of pulses	5 ... 1500

## Incremental

## Solid Shaft

**TECHNICAL DATA**  
**electrical (continued)**

Alarm output	NPN-O.C., max. 5 mA
Pulse shape	Square wave
Pulse duty factor	1:1

<sup>1</sup> With push-pull (K): pole protection

<sup>2</sup> Output description and technical data see chapter "Technical basics"

**ELECTRICAL CONNECTIONS**  
**Cable**

Description (push-pull)	Description (RS422)	Lead Ø mm <sup>2</sup>	Colour
DC 10 - 30 V	DC 5 V	0.5	red
	Sense V <sub>CC</sub>	0.14	yellow/red
Channel A	Channel A	0.14	white
	Channel $\bar{A}$	0.14	white/brown
Channel B	Channel B	0.14	green
	Channel $\bar{B}$	0.14	green/brown
Channel N	Channel N	0.14	yellow
	Channel $\bar{N}$	0.14	yellow/brown
GND	GND	0.5	black
Alarm	Alarm/Sense GND <sup>1</sup>	0.14	yellow/black
screen <sup>2</sup>	screen <sup>2</sup>		screen <sup>2</sup>

<sup>1</sup> depending on ordering code

<sup>2</sup> connected with encoder housing

**ELECTRICAL CONNECTIONS**  
**M16 connector (Binder), 6 pole**

Description (push-pull)	Pin
DC 10 - 30 V	1
Channel A	2
Channel N	3
Channel B	4
Alarm	5
GND	6



### DIMENSIONED DRAWINGS

Synchro flange, cable

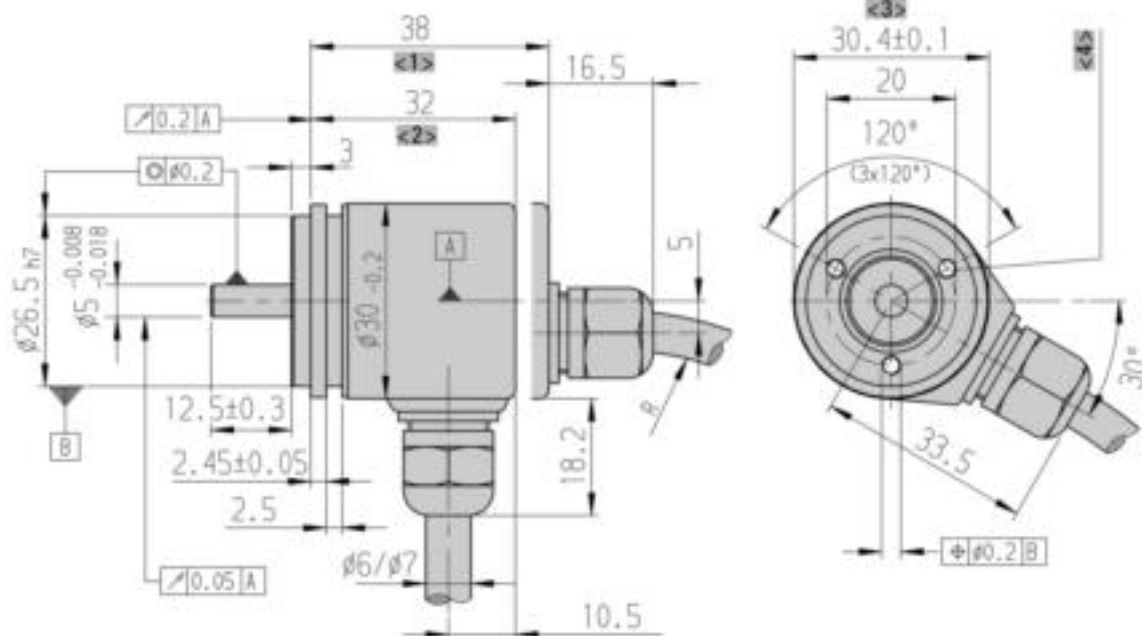

- <1> axial
- <2> radial
- <3> Housing

- <4> mounting thread M3x5
- Cable bending radius R for flexible installation  $\geq 100$  mm
- Cable bending radius R for fixed installation  $\geq 40$  mm

Dimensions in mm

Pilot flange, cable

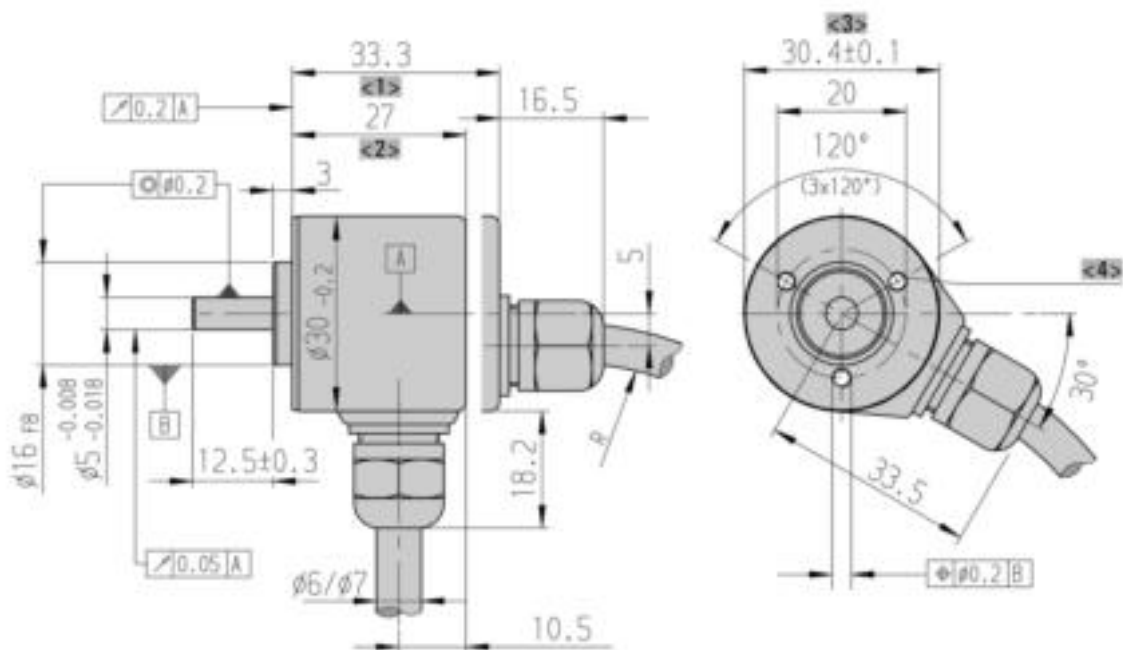

- <1> axial
- <2> radial
- <3> Housing

- <4> mounting thread M3x5
- Cable bending radius R for flexible installation  $\geq 100$  mm
- Cable bending radius R for fixed installation  $\geq 40$  mm

Dimensions in mm

**DIMENSIONED DRAWINGS (continued)**

**Synchro flange, M16 (Binder)**

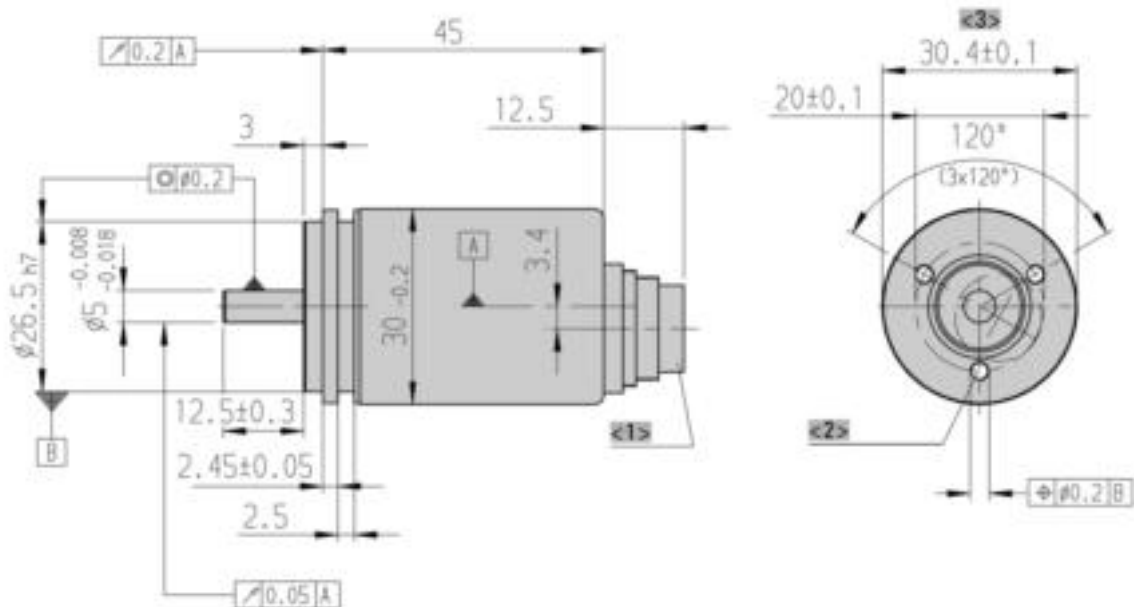

<1> 6 pole (pins)

<2> mounting thread M3x5

<3> Housing

Dimensions in mm

**Pilot flange, M16 (Binder)**

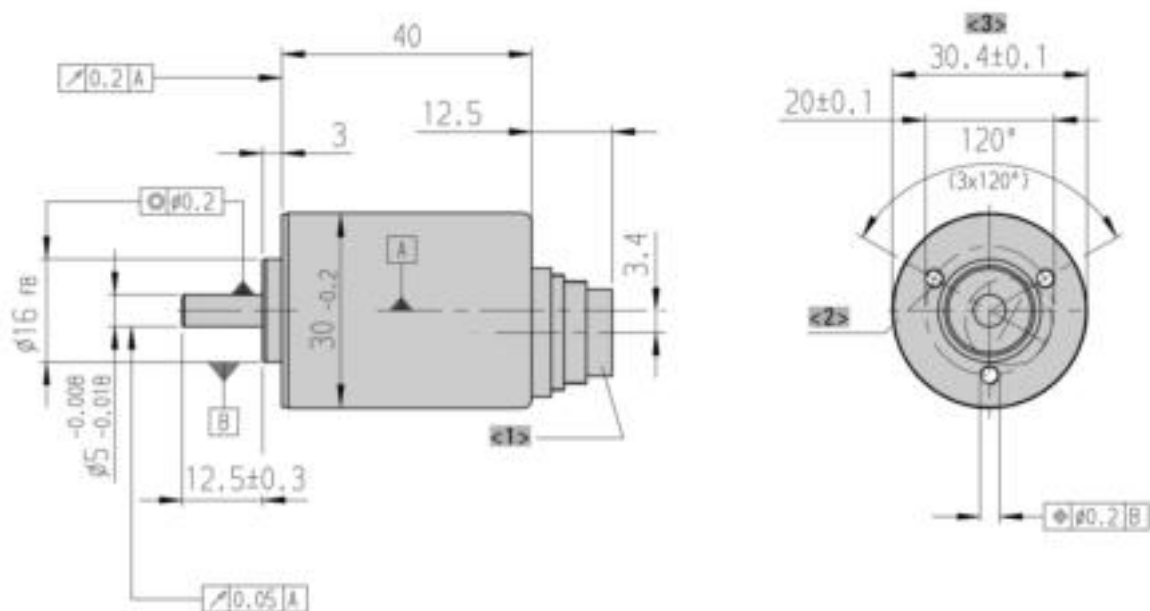

<1> 6 pole (pins)

<2> mounting thread M3x5

<3> Housing

Dimensions in mm

### ORDERING INFORMATION

Type	Number of pulses	Supply voltage <sup>1</sup>	Flange, Protection, Shaft	Output <sup>2</sup>	Connection <sup>3</sup>
<input type="checkbox"/>	<input type="checkbox"/>	<input type="checkbox"/>	<input type="checkbox"/>	<input type="checkbox"/>	<input type="checkbox"/>
<b>RI30-0</b>	<b>5 ... 1500</b>	<b>A</b> DC 5 V <b>E</b> DC 10 - 30 V	<b>S.34</b> Synchro, IP64, 5 mm <b>R.34</b> Pilot, IP64, 5 mm	<b>R</b> RS422 +Alarm <b>T</b> RS422 +Sense <b>K</b> Push-pull	<b>A</b> Cable, axial <b>B</b> Cable, radial <b>E-I</b> M23 connector (Conin) at 1 m TPE cable, cw <b>E-D</b> M23 connector (Conin) at 1 m TPE cable, ccw <b>N</b> M16 connector (Binder), 6 pole, axial

<sup>1</sup> DC 10 - 30 V only with push-pull

<sup>2</sup> Output code "K": short-circuit-proof

<sup>3</sup> For Output Code "N" (M16): only push-pull

### ORDERING INFORMATION

#### Selection of cable length

Versions with cable outlet (connection A, B, E or F) are available with various lengths of cable. To order your desired cable length, please add the respective code to the end of your ordering code. Further cable lengths on request.

Code	Cable length
without code	1.5 m
-D0	3 m
-F0	5 m
-K0	10 m
-P0	15 m
-U0	20 m
-V0	25 m

### ACCESSORIES

see chapter "Accessories", starting page 322

## Incremental

## Solid Shaft



### NUMBER OF PULSES

- Miniature industry standard encoder for high numbers of pulses
- High reliability
- Applications: CNC axles, machine tools, robots, special purpose machines, high-speed winding machines



5 / 10 / 20 / 25 / 28 / 32 / 50 / 60 / 72 / 100 / 128 / 144 / 200 / 250 / 256 / 288 / 300 / 360 / 400 / 500 / 512 / 600 / 720 / 900 / 1000 / 1024 / 1250 / 1500 / 2000 / 2048 / 2500 / 3000 / 3600  
Other number of pulses on request

### TECHNICAL DATA mechanical

Housing diameter	36 mm
Shaft diameter	6 mm / 6.35 mm (Solid shaft)
Flange (Mounting of housing)	Synchro flange, Pilot flange
Protection class shaft input (EN 60529)	IP64
Protection class housing (EN 60529)	IP64
Shaft load axial / radial	5 N / 10 N
Max. speed	max. 10 000 rpm
Torque	≤ 0.3 Ncm
Moment of inertia	approx. 2.8 gcm <sup>2</sup>
Vibration resistance (DIN EN 60068-2-6)	100 m/s <sup>2</sup> (10 ... 2000 Hz)
Shock resistance (DIN EN 60068-2-27)	1000 m/s <sup>2</sup> (6 ms)
Operating temperature	-10 °C ... +70 °C
Storage temperature	-25 °C ... +85 °C
Material housing	Aluminum
Weight	approx. 80 g
Connection	Cable, axial or radial M16 (Binder), axial or radial

### TECHNICAL DATA electrical

General design	as per DIN VDE 0160, protection class III, contamination level 2, overvoltage class II
Supply voltage <sup>1</sup>	RS422 + Alarm (R), RS422 + Sense (T): DC 5 V ±10 % Push-pull (K), Push-pull antivalent (I): DC 10-30 V
Max. current w/o load	40 mA (DC 5 V), 60 mA (DC 10 V), 30 mA (DC 24 V)
Max. pulse frequency	RS422: 300 kHz Push-pull: 200 kHz
Standard output versions <sup>2</sup>	RS422 + Sense (T): A, B, N, $\bar{A}$ , $\bar{B}$ , $\bar{N}$ , Sense RS422 + Alarm (R): A, B, N, $\bar{A}$ , $\bar{B}$ , $\bar{N}$ , Alarm Push-pull (K): A, B, N, $\bar{A}$ Alarm Push-pull complementary (I): A, B, N, $\bar{A}$ , $\bar{B}$ , $\bar{N}$ , $\bar{A}$ Alarm
Pulse width error	± max. 25° electrical
Number of pulses	5 ... 3600
Alarm output	NPN-O.C., max. 5 mA

Incremental

Solid Shaft

**TECHNICAL DATA**  
electrical (continued)

Pulse shape	Square wave
Pulse duty factor	1:1

<sup>1</sup> With push-pull (K) and push-pull complementary (I): pole protection

<sup>2</sup> Output description and technical data see chapter "Technical basics"

**ELECTRICAL CONNECTIONS**  
Cable PVC

Cable PVC (A, B)		Output		
Colour	Lead mm <sup>2</sup>	RS422 (R, T)	push-pull (K)	push-pull complementary (I)
red	0.5	DC 5 V	DC 10 - 30 V	DC 10 - 30 V
yellow/red	0.14	Sense V <sub>CC</sub>		Sense V <sub>CC</sub>
white	0.14	Channel A	Channel A	Channel A
white/brown	0.14	Channel $\bar{A}$		Channel $\bar{A}$
green	0.14	Channel B	Channel B	Channel B
green/brown	0.14	Channel $\bar{B}$		Channel $\bar{B}$
yellow	0.14	Channel N	Channel N	Channel N
yellow/brown	0.14	Channel $\bar{N}$		Channel $\bar{N}$
black	0.5	GND	GND	GND
yellow/black	0.14	Alarm/Sense GND <sup>1</sup>	Alarm	Alarm
screen <sup>2</sup>		screen <sup>2</sup>	screen <sup>2</sup>	screen <sup>2</sup>

<sup>1</sup> depending on ordering code

<sup>2</sup> connected with encoder housing

**ELECTRICAL CONNECTIONS**  
M16 connector (Binder), 6 pole

Description (push-pull)	Pin
DC 10 - 30 V	1
Channel A	2
Channel N	3
Channel B	4
Alarm	5
GND	6

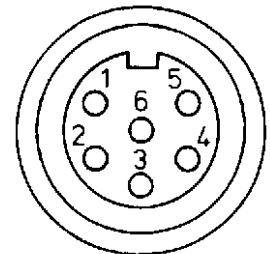

## DIMENSIONED DRAWINGS

### Synchro flange

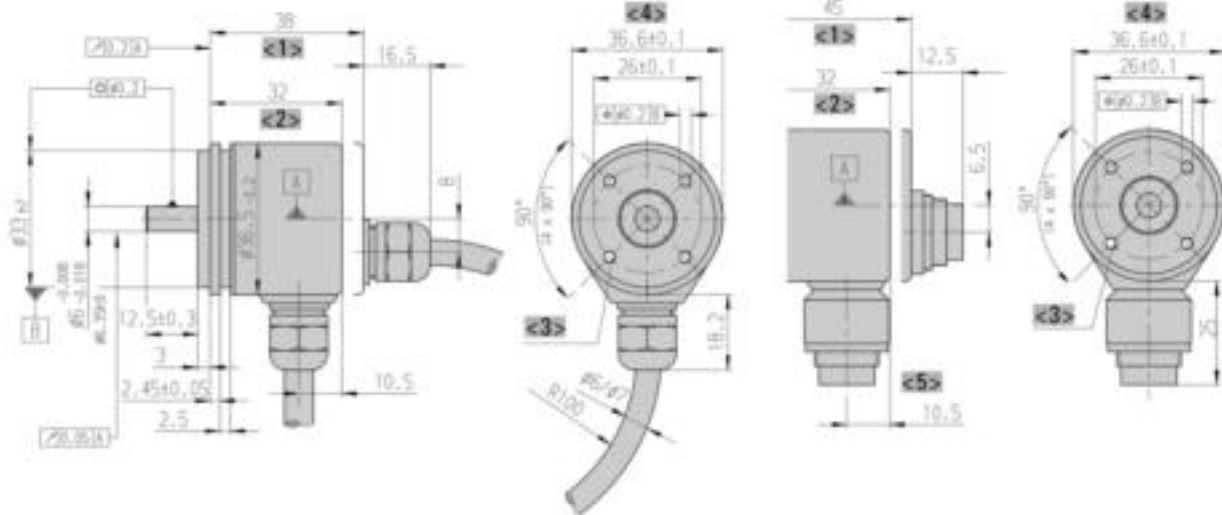

- <1> axial
- <2> radial
- <3> mounting thread M3x5
- <4> Housing
- <5> 6 pole (pins)

Cable bending radius R for flexible installation  $\geq 100$  mm  
Cable bending radius R for fixed installation  $\geq 40$  mm

Dimensions in mm

### Pilot flange

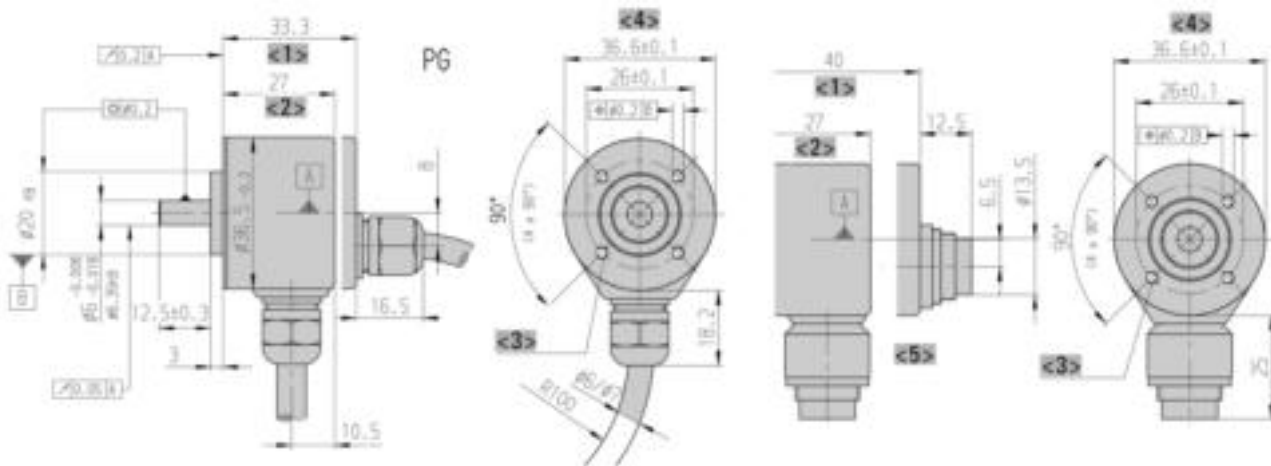

- <1> axial
- <2> radial
- <3> mounting thread M3x5
- <4> Housing
- <5> 6 pole (pins)

Cable bending radius R for flexible installation  $\geq 100$  mm  
Cable bending radius R for fixed installation  $\geq 40$  mm

Dimensions in mm

### ORDERING INFORMATION

Type	Number of pulses	Supply voltage <sup>1</sup>	Flange, Protection, Shaft	Output <sup>2</sup>	Connection <sup>3</sup>
<input type="checkbox"/>	<input type="checkbox"/>	<input type="checkbox"/>	<input type="checkbox"/>	<input type="checkbox"/>	<input type="checkbox"/>
<b>RI36-0</b>	<b>5 ... 3600</b>	<b>A</b> DC 5 V <b>E</b> DC 10 - 30 V	<b>S.31</b> Synchro, IP64, 6 mm <b>S.35</b> Synchro, IP64, 6,35 mm <b>R.31</b> Pilot, IP64, 6 mm <b>R.35</b> Pilot, IP64, 6,35 mm	<b>R</b> RS422 +Alarm <b>T</b> RS422 +Sense <b>K</b> Push-pull <b>I</b> Push-pull complementary	<b>A</b> Cable, axial <b>B</b> Cable, radial <b>E-I</b> M23 connector (Conin) at 1 m TPE cable, cw <b>E-D</b> M23 connector (Conin) at 1 m TPE cable, ccw <b>J</b> M16 connector (Binder), 6 pole, radial <b>N</b> M16 connector (Binder), 6 pole, axial

<sup>1</sup> DC 10 - 30 V only with output push-pull (K) and push-pull complementary (I)

<sup>2</sup> Output code "K" and "I": short-circuit-proof

<sup>3</sup> For Output Code "N" und "J" (M16): only push-pull

### ORDERING INFORMATION

#### Selection of cable length

Versions with cable outlet (connection A, B, E or F) are available with various lengths of cable. To order your desired cable length, please add the respective code to the end of your ordering code. Further cable lengths on request.

Code	Cable length
without code	1.5 m
-D0	3 m
-F0	5 m
-K0	10 m
-P0	15 m
-U0	20 m
-V0	25 m

### ACCESSORIES

see chapter "Accessories", starting page 322

**Incremental**

**Solid Shaft**



Synchro flange



Clamping flange

- Universal industry standard encoder
- Up to 40 000 steps with 10 000 pulses
- High signal accuracy
- Protection class up to IP67
- Flexible due to many flange and configuration variants
- Suitable for high shock ratings
- Applications: machine tools, CNC axles, packing machines, motors/ drives, injection moulding machines, sawing machines, textile machines
- For EX version, see RX 70-I
- Operating temperature up to 100 °C (RI 58-T)



**NUMBER OF PULSES**

RI 58-0

1 / 2 / 3 / 4 / 5 / 10 / 15 / 20 / 25 / 30 / 35 / 40 / 45 / 50 / 60 / 64 / 70 / 72 / 80 / **100** / 125 / 128 / 144 / 150 / 180 / 200 / 230 / **250** / 256 / 300 / 314 / 350 / 360 / 375 / 400 / 460 / 480 / **500** / 512 / 600 / 625 / 635 / 720 / 750 / 900 / **1000** / **1024** / 1200 / **1250** / 1500 / 1600 / 1800 / 2000 / 2048 / **2500** / 3000 / 3480 / **3600** / 3750 / 3968 / 4000 / **4096** / 4800 / **5000** / 5400 / 6000 / 7200 / 7680 / 8000 / 8192 / 9000 / 10000

Other number of pulses on request

Preferably available versions are printed in bold type.

RI 58-T

4 / 5 / 10 / 15 / 20 / 25 / 30 / 35 / 40 / 45 / 50 / 60 / 64 / 70 / 72 / 80 / **100** / 125 / 128 / 144 / 150 / 180 / 200 / 230 / **250** / 256 / 300 / 314 / 350 / 360 / 375 / 400 / 460 / 480 / **500** / 512 / 600 / 625 / 635 / 720 / 750 / 900 / **1000** / **1024** / 1200 / **1250** / 1500 / 1600 / 1800 / 2000 / 2048 / **2500**

Other number of pulses on request

Preferably available versions are printed in bold type.

**TECHNICAL DATA**  
**mechanical**

Housing diameter	58 mm
Shaft diameter	6 mm / 6.35 mm / 7 mm / 9.52 mm / 10 mm / 12 mm (Solid shaft)
Flange (Mounting of housing)	Synchro flange, Clamping flange, Square flange, Synchro clamping flange
Protection class shaft input (EN 60529)	IP64 or IP67
Protection class housing (EN 60529)	IP65 or IP67
Shaft load axial / radial	Ø 6 mm / 6,35 mm: 20 N / 40 N Ø 7 ... 10 mm: 40 N / 60 N Ø 12 mm: 60 N / 80 N
Max. speed	max. 10 000 rpm
Torque	≤ 0.5 Ncm ≤ 1 Ncm (IP67)
Moment of inertia	approx. 14 gcm <sup>2</sup> (Synchro flange) approx. 20 gcm <sup>2</sup> (Clamping flange)



**Incremental**
**Solid Shaft**
**TECHNICAL DATA  
mechanical (continued)**

Vibration resistance (DIN EN 60068-2-6)	100 m/s <sup>2</sup> (10 ... 2000 Hz)
Shock resistance (DIN EN 60068-2-27)	1000 m/s <sup>2</sup> (6 ms)
Operating temperature	RI 58-O: -10 °C ... +70 °C RI 58-T: -25 °C ... +100 °C
Storage temperature	RI 58-O: -25 °C ... +85 °C RI 58-T: -25 °C ... +100 °C
Material housing	Aluminum
Weight	approx. 360 g
Connection	PVC cable, axial or radial M23 connector (Conin), axial or radial TPE cable, axial or radial M16 (Binder), axial or radial MS, axial oder radial

**TECHNICAL DATA  
electrical**

General design	as per DIN VDE 0160, protection class III, contamination level 2, overvoltage class II
Supply voltage <sup>1</sup>	RS422 + Sense (T): DC 5 V ±10 % RS422 + Alarm (R): ± 10% DC 5 V or DC 10 - 30 V Push-pull (K), Push-pull antivalent (I): DC 10-30 V
Max. current w/o load	40 mA (DC 5 V), 60 mA (DC 10 V), 30 mA (DC 24 V)
Max. pulse frequency	RS422: 300 kHz Push-pull: 200 kHz
Standard output versions <sup>2</sup>	RS422 + Alarm (R): A, B, N, $\overline{A}$ , $\overline{B}$ , $\overline{N}$ , $\overline{Alarm}$ RS422 + Sense (T): A, B, N, $\overline{A}$ , $\overline{B}$ , $\overline{N}$ , Sense Push-pull (K): A, B, N, $\overline{Alarm}$ Push-pull complementary (I): A, B, N, $\overline{A}$ , $\overline{B}$ , $\overline{N}$ , $\overline{Alarm}$
Pulse width error	± max. 25° electrical
Number of pulses	1 ... 10 000
Alarm output	NPN-O.C., max. 5 mA
Pulse shape	Square wave
Pulse duty factor	1:1

<sup>1</sup> Pole protection with supply voltage DC 10 - 30 V

<sup>2</sup> Output description and technical data see chapter "Technical basics"

## Incremental

## Solid Shaft

### ELECTRICAL CONNECTIONS

#### Cable PVC

Cable PVC (A, B) Colour	Output		
	RS422 (R, T)	push-pull (K)	push-pull complementary (I)
red	DC 5 / 10 - 30 V	DC 10 - 30 V	DC 10 - 30 V
yellow/red	Sense V <sub>cc</sub>		Sense V <sub>cc</sub>
white	Channel A	Channel A	Channel A
white/brown	Channel $\bar{A}$		Channel $\bar{A}$
green	Channel B	Channel B	Channel B
green/brown	Channel $\bar{B}$		Channel $\bar{B}$
yellow	Channel N	Channel N	Channel N
yellow/brown	Channel $\bar{N}$		Channel $\bar{N}$
black	GND	GND	GND
yellow/black	$\bar{\text{Alarm}}$ /Sense GND <sup>1</sup>	$\bar{\text{Alarm}}$	$\bar{\text{Alarm}}$
screen <sup>2</sup>	screen <sup>2</sup>	screen <sup>2</sup>	screen <sup>2</sup>

<sup>1</sup> depending on ordering code

<sup>2</sup> connected with encoder housing

### ELECTRICAL CONNECTIONS

#### Cable TPE

Cable TPE (E, F) Colour	Output		
	RS422 (R, T)	push-pull (K)	push-pull complementary (I)
brown/green	DC 5 / 10 - 30 V	DC 10 - 30 V	DC 10 - 30 V
blue	Sense V <sub>cc</sub>		Sense V <sub>cc</sub>
brown	Channel A	Channel A	Channel A
green	Channel $\bar{A}$		Channel $\bar{A}$
grey	Channel B	Channel B	Channel B
pink	Channel $\bar{B}$		Channel $\bar{B}$
red	Channel N	Channel N	Channel N
black	Channel $\bar{N}$		Channel $\bar{N}$
white/green	GND	GND	GND
violet (white) <sup>1</sup>	$\bar{\text{Alarm}}$ /Sense GND <sup>2</sup>	$\bar{\text{Alarm}}$	$\bar{\text{Alarm}}$
screen <sup>3</sup>	screen <sup>3</sup>	screen <sup>3</sup>	screen <sup>3</sup>

<sup>1</sup> white with RS422 + Sense (T)

<sup>2</sup> depending on ordering code

<sup>3</sup> connected with encoder housing

**Incremental**

**Solid Shaft**

**ELECTRICAL CONNECTIONS**  
M23 connector (Conin), 12 pole

Pin	RS422 + Sense (T)	RS422 + Alarm (R)	push-pull (K)	push-pull complementary (I)
1	Channel $\bar{B}$	Channel $\bar{B}$	N.C.	Channel $\bar{B}$
2	Sense $V_{CC}$	Sense $V_{CC}$	N.C.	Sense $V_{CC}$
3	Channel N	Channel N	Channel N	Channel N
4	Channel $\bar{N}$	Channel $\bar{N}$	N.C.	Channel $\bar{N}$
5	Channel A	Channel A	Channel A	Channel A
6	Channel $\bar{A}$	Channel $\bar{A}$	N.C.	Channel $\bar{A}$
7	N.C.	$\bar{A}larm$	$\bar{A}larm$	$\bar{A}larm$
8	Channel B	Channel B	Channel B	Channel B
9	N.C. <sup>1</sup>	N.C. <sup>1</sup>	N.C. <sup>1</sup>	N.C. <sup>1</sup>
10	GND	GND	GND	GND
11	Sense GND	N.C.	N.C.	N.C.
12	DC 5 V	DC 10 - 30 V	DC 10 - 30 V	DC 10 - 30 V

<sup>1</sup> screen for cable with CONIN connector

**ELECTRICAL CONNECTIONS**  
MS connector, 10 pole

Pin	Description RS422 / Euro-pinout (Connection codes O and K)	push-pull	push-pull complementary
1/A	Channel A	Channel A	Channel A
2/B	Channel B	Channel B	Channel B
3/C	Channel N	Channel N	Channel N
4/D	DC 5/10 - 30 V	DC 10 - 30 V	DC 10 - 30 V
5/E	$\bar{A}larm$	$\bar{A}larm$	$\bar{A}larm$
6/F	GND	GND	GND
7/G	Channel $\bar{A}$	screen	Channel $\bar{A}$
8/H	Channel $\bar{B}$	N.C.	Channel $\bar{B}$
9/I	Channel $\bar{N}$	N.C.	Channel $\bar{N}$
10/J	screen	screen	screen

**ELECTRICAL CONNECTIONS**  
M16 connector (Binder), 6 pole

Description (push-pull)	Pin
DC 10 - 30 V	1
Channel A	2
Channel N	3
Channel B	4
$\bar{A}larm$	5
GND	6

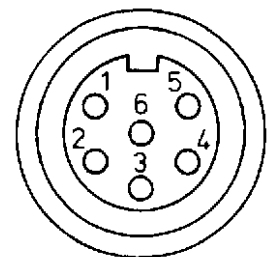

# Standard Industrial Types RI 58-0 / RI 58-T

## Incremental Solid Shaft

### DIMENSIONED DRAWINGS

#### Synchro flange, 58 mm

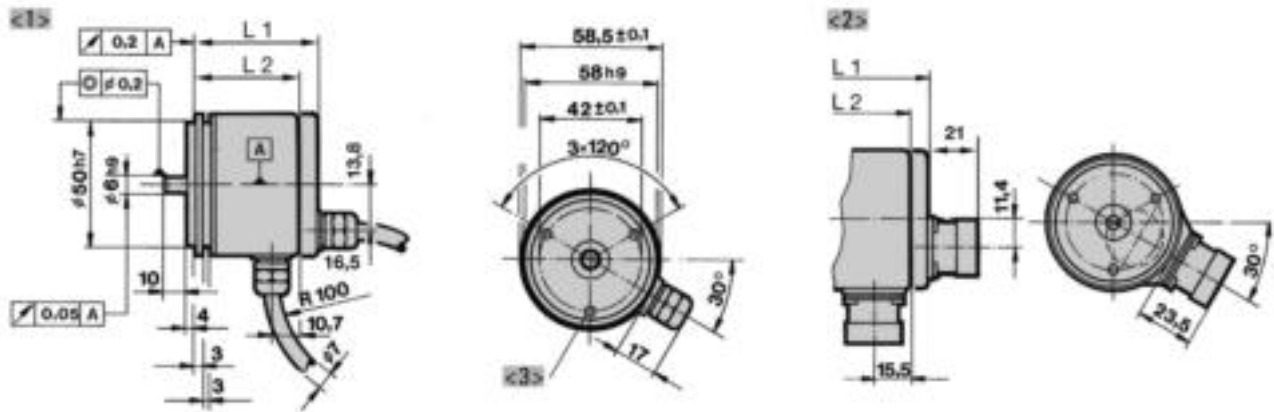

- <1> Connection cable, axial/radial
- <2> M23, 12 pole, axial/ radial
- <3> mounting thread M4x5

Cable bending radius R for flexible installation  $\geq 100$  mm  
 Cable bending radius R for fixed installation  $\geq 40$  mm

Dimensions in mm

#### Clamping flange, 58 mm

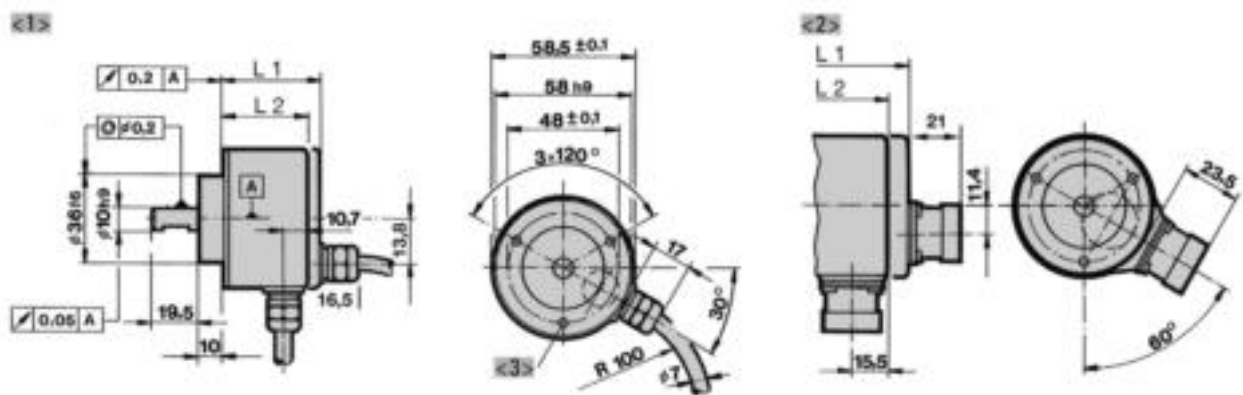

- <1> Connection cable, axial/radial
- <2> M23, 12 pole, axial/ radial
- <3> mounting thread M3x5 (Option M4x5)

Cable bending radius R for flexible installation  $\geq 100$  mm  
 Cable bending radius R for fixed installation  $\geq 40$  mm

Dimensions in mm

# Standard Industrial Types RI 58-0 / RI 58-T Incremental Solid Shaft

**DIMENSIONED DRAWINGS (continued)**

**Synchro clamping flange, 63,5 mm (2,5")**

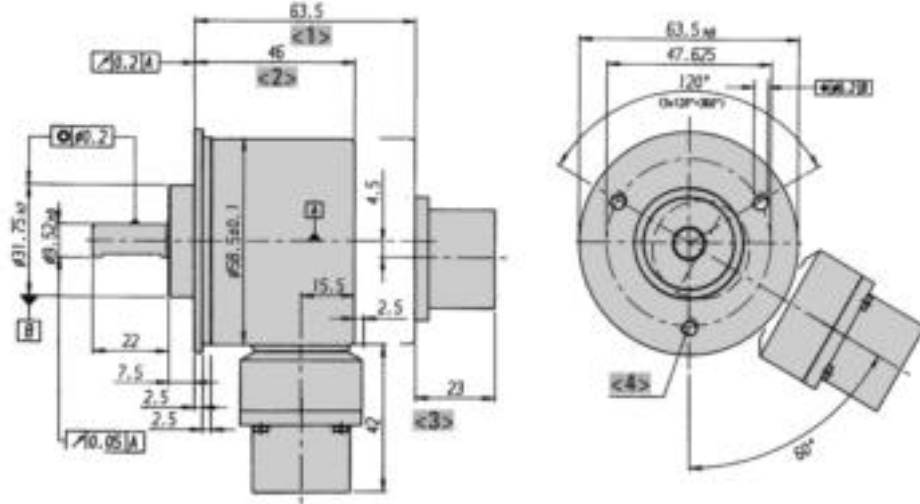

<1> axial  
<2> radial

<3> MS 6 - 10 pole  
<4> Screw thread 10-32 UNF

Dimensions in mm

**Square flange, 63,5 mm x 63,5 mm (2,5" x 2,5')**

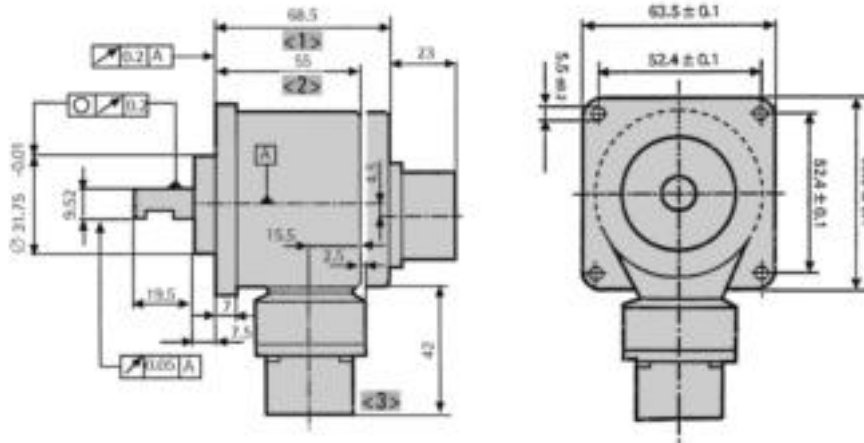

<1> axial  
<2> radial

<3> MS 6 - 10 pole

Dimensions in mm

DIMENSIONED DRAWINGS (continued)

Square flange 80 x 80 mm

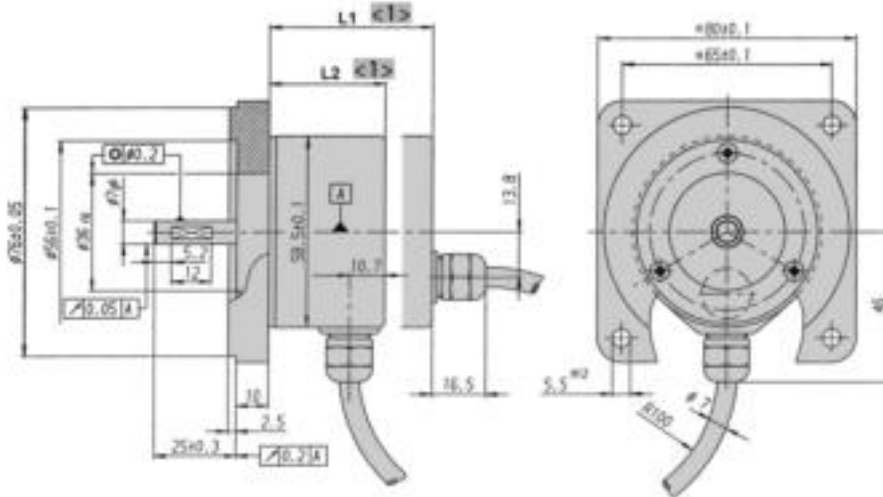

<1> L1, L2 see clamping flange  
Cable bending radius R for flexible installation ≥ 100 mm

Cable bending radius R for fixed installation ≥ 40 mm

Dimensions in mm

DIMENSIONS

Typ	Connection	Output	axial L1 mm	radial L2 mm
Synchro flange, 58 mm	cable	R (with U <sub>B</sub> = DC 5 V), T, K, I	51.5	41.5
		R (with U <sub>B</sub> = DC 10 - 30 V)	56	56
	connector	R (with U <sub>B</sub> = DC 5 V), T, K, I	57.5	51.5
		R (with U <sub>B</sub> = DC 10 - 30 V)	57.5	56
Clamping flange, 58 mm / Square flange, 80x80 mm	cable	R (with U <sub>B</sub> = DC 5 V), T, K, I	45.5	35.5
		R (with U <sub>B</sub> = DC 10 - 30 V)	50	50
	connector	R (with U <sub>B</sub> = DC 5 V), T, K, I	51.5	45.5
		R (with U <sub>B</sub> = DC 10 - 30 V)	51.5	50

# Standard Industrial Types RI 58-O / RI 58-T

## Incremental Solid Shaft

### STANDARD VERSIONS

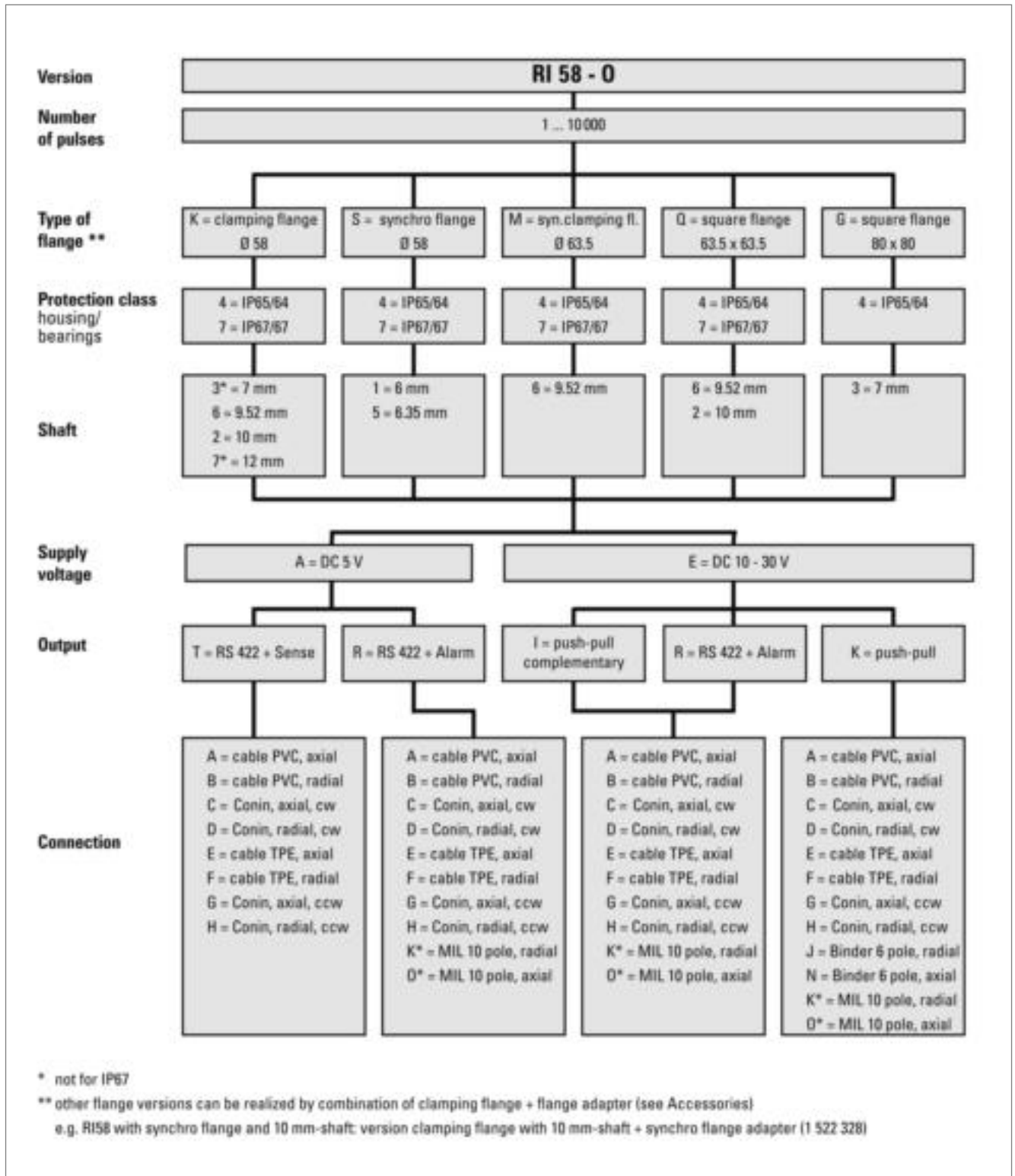

STANDARD VERSIONS (100 °C max. operating temperature)

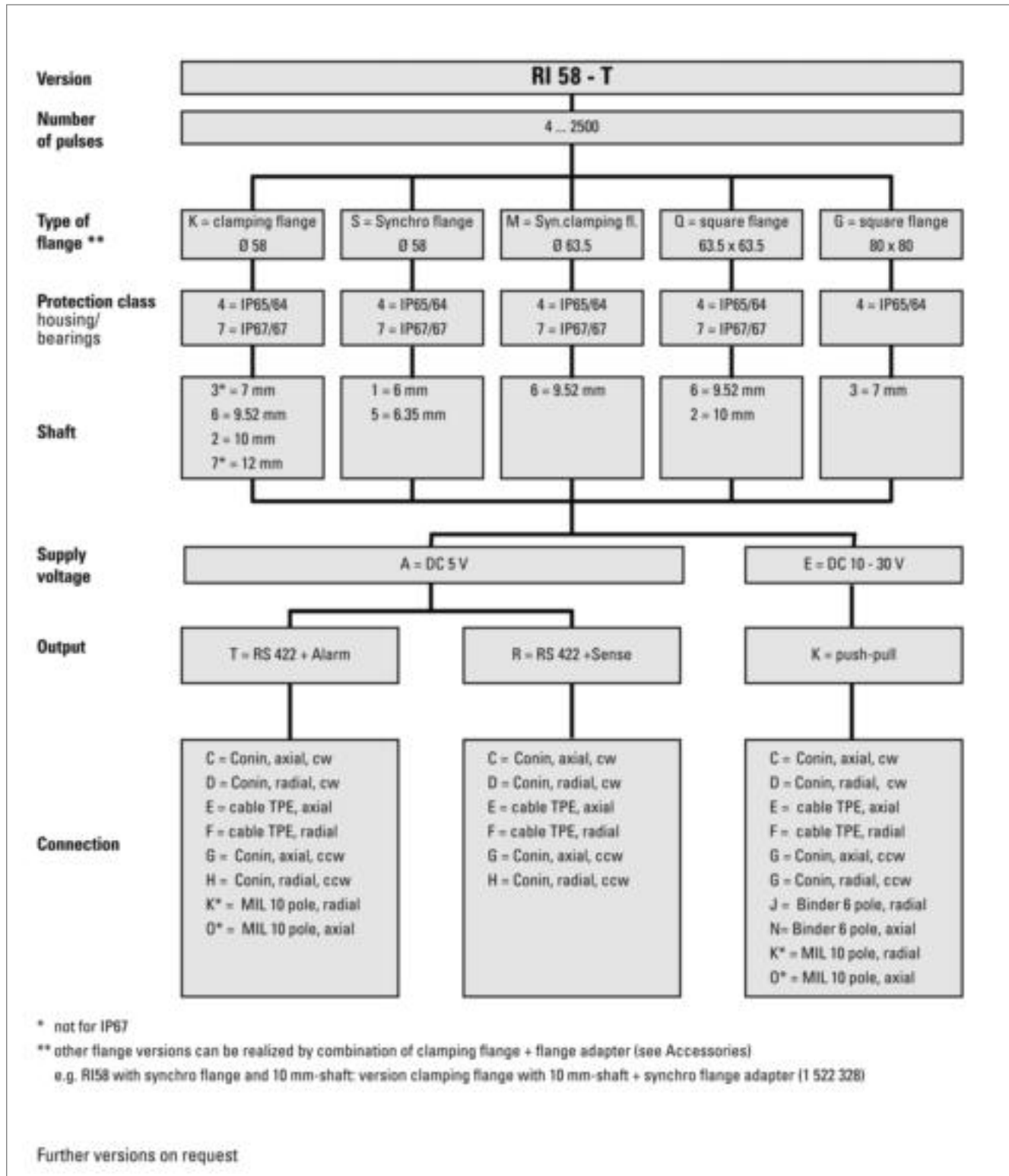



# Standard Industrial Types **RI 58-O / RI 58-T**

## Incremental **Solid Shaft**

### ORDERING INFORMATION

Type	Number of pulses	Supply voltage <sup>1</sup>	Flange, Protection, Shaft <sup>2,3</sup>	Output <sup>4</sup>	Connection <sup>5,6</sup>
□	□	□	□	□	□
<b>RI58-O</b> <b>RI58-T</b>	RI 58-O: <b>1 ... 10000</b> RI 58-T: <b>4 ... 2500</b>	<b>A</b> DC 5 V <b>E</b> DC 10 - 30 V	<b>S.41</b> Synchro, IP64, 6 mm <b>S.45</b> Synchro, IP64, 6.35 mm <b>S.71</b> Synchro, IP67, 6 mm <b>S.75</b> Synchro, IP67, 6.35 mm <b>K.42</b> Clamping, IP64, 10 mm <b>K.47</b> Clamping, IP64, 12 mm <b>K.43</b> Clamping, IP64, 7 mm <b>K.46</b> Clamping, IP64, 9.52 mm <b>K.72</b> Clamping, IP67, 10 mm <b>K.76</b> Clamping, IP67, 9.52 mm <b>M.46</b> Syn.clamping, IP64, 9.52 mm <b>M.76</b> Syn.clamping, IP67, 9.52 mm <b>O.46</b> Square, IP64, 9.52 mm <b>O.42</b> Square, IP64, 10 mm <b>O.76</b> Square, IP67, 9.52 mm <b>O.72</b> Square, IP67, 10 mm <b>G.73</b> Square 80x80, IP67, 7 mm	<b>R</b> RS422 +Alarm <b>T</b> RS422 +Sense <b>K</b> Push-pull <b>I</b> Push-pull complementary	<b>A</b> PVC cable, axial <b>B</b> PVC cable, radial <b>E</b> TPE cable, axial <b>F</b> TPE cable, radial <b>C</b> M23 connector (Conin), 12 pole, axial, cw <b>D</b> M23 connector (Conin), 12 pole, radial, cw <b>G</b> M23 connector (Conin), 12 pole, axial, ccw <b>H</b> M23 connector (Conin), 12 pole, radial, ccw <b>J</b> M16 connector (Binder), 6 pole, radial <b>N</b> M16 connector (Binder), 6 pole, axial <b>O</b> MS connector, 10 pole (Insert arrangement 18-1), axial <b>K</b> MS connector, 10 pole (Insert arrangement 18-1), radial

<sup>1</sup> DC 10 - 30 V only with push-pull

<sup>2</sup> other flange versions can be realized by combination of clamping flange + flange adapter (see Accessories), e.g. RI58 with synchro flange and 10 mm-shaft: version clamping flange with 10 mm-shaft + synchro flange adapter (1 522 328)

<sup>3</sup> Output code "K" and "I": short-circuit-proof

<sup>4</sup> Connection code "O", "K": according to MIL-C-5015 (only RI 58-O)

<sup>5</sup> IP67 on cover with connector only if IP67 mating connector mounted properly.

<sup>6</sup> Connection code "O", "K": according to MIL-C-5016 (only RI 58-T)

### ORDERING INFORMATION

#### Selection of cable length

Versions with cable outlet (connection A, B, E or F) are available with various lengths of cable. To order your desired cable length, please add the respective code to the end of your ordering code. Further cable lengths on request.

Code	Cable length
without code	1.5 m
-D0	3 m
-F0	5 m
-K0	10 m
-P0	15 m
-U0	20 m
-V0	25 m

### ACCESSORIES

see chapter "Accessories", starting page 322

## Incremental

## Hollow Shaft



### NUMBER OF PULSES

- Miniature industry encoder for high number of pulses
- Short mounting length
- Easy mounting procedure
- Applications: motors, machine tools, robots, automated SMD equipment



5 / 10 / 20 / 25 / 50 / 60 / 100 / 200 / 250 / 300 / 360 / 500 / 600 / 720 / 1000 / 1024 / 1250 / 1500 / 2000 / 2048 / 2500 / 3000 / 3600  
Other number of pulses on request

### TECHNICAL DATA mechanical

Housing diameter	36 mm
Shaft diameter	4 mm / 6 mm / 8 mm / 10 mm (Hubshaft)
Flange (Mounting of housing)	Tether
Mounting of shaft	Front clamping ring
Protection class shaft input (EN 60529)	IP64
Protection class housing (EN 60529)	IP64
Axial endplay of mounting shaft (hubshaft)	± 0.5 mm
Radial runout of mating shaft (hubshaft)	± 0.15 mm
Max. speed	max. 10 000 rpm
Torque	≤ 1 Ncm
Moment of inertia	approx. 3 gcm <sup>2</sup>
Vibration resistance (DIN EN 60068-2-6)	100 m/s <sup>2</sup> (10 ... 2000 Hz)
Shock resistance (DIN EN 60068-2-27)	1000 m/s <sup>2</sup> (6 ms)
Operating temperature	-10 °C ... +70 °C
Storage temperature	-25 °C ... +85 °C
Material housing	Aluminum
Weight	approx. 80 g
Connection	Cable, axial or radial

### TECHNICAL DATA electrical

General design	as per DIN EN 61010-1, protection class III, contamination level 2, overvoltage class II
Supply voltage <sup>1</sup>	RS422 + Alarm (R), RS422 + Sense (T): DC 5 V ±10 % Push-pull (K), Push-pull antivalent (I): DC 10-30 V
Max. current w/o load	40 mA (DC 5 V), 60 mA (DC 10 V), 30 mA (DC 24 V)
Max. pulse frequency	RS422: 300 kHz Push-pull: 200 kHz
Standard output versions <sup>2</sup>	RS422 + Sense (T): A, B, N, $\bar{A}$ , $\bar{B}$ , $\bar{N}$ , Sense RS422 + Alarm (R): A, B, N, $\bar{A}$ , $\bar{B}$ , $\bar{N}$ , Alarm Push-pull (K): A, B, N, Alarm Push-pull complementary (I): A, B, N, $\bar{A}$ , $\bar{B}$ , $\bar{N}$ , Alarm

Incremental

Hollow Shaft

TECHNICAL DATA  
electrical (continued)

Pulse width error	± max. 25° electrical
Number of pulses	5 ... 3600
Alarm output	NPN-O.C., max. 5 mA
Pulse shape	Square wave
Pulse duty factor	1:1

<sup>1</sup> With push-pull (K) and push-pull complementary (I): pole protection

<sup>2</sup> Output description and technical data see chapter "Technical basics"

ELECTRICAL CONNECTIONS  
Cable PVC

Cable PVC (A, B)		Output		
Colour	Litze mm <sup>2</sup>	RS422 (R, T)	push-pull (K)	push-pull complementary (I)
red	0.5	DC 5 V	DC 10 - 30 V	DC 10 - 30 V
yellow/red	0.14	Sense V <sub>CC</sub>		Sense V <sub>CC</sub>
white	0.14	Channel A	Channel A	Channel A
white/brown	0.14	Channel $\bar{A}$		Channel $\bar{A}$
green	0.14	Channel B	Channel B	Channel B
green/brown	0.14	Channel $\bar{B}$		Channel $\bar{B}$
yellow	0.14	Channel N	Channel N	Channel N
yellow/brown	0.14	Channel $\bar{N}$		Channel $\bar{N}$
black	0.5	GND	GND	GND
yellow/black	0.14	$\bar{\text{Alarm}}$ /Sense GND <sup>1</sup>	$\bar{\text{Alarm}}$	$\bar{\text{Alarm}}$
screen <sup>2</sup>		screen <sup>2</sup>	screen <sup>2</sup>	screen <sup>2</sup>

<sup>1</sup> depending on ordering code

<sup>2</sup> connected with encoder housing

DIMENSIONED DRAWINGS

Torque support "J"

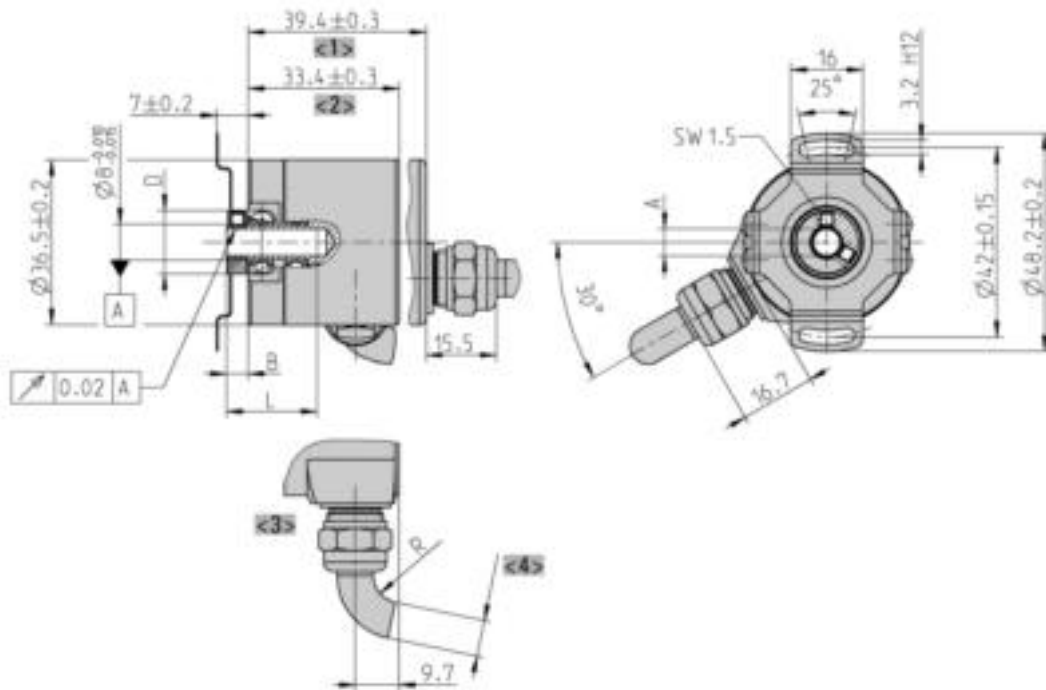

Dim.	Hollow shaft $\phi$				Unit
A	4 $+0.01$	6 $+0.01$	8 $+0.01$	10 $+0.01$	mm
A*	4 $g7$	10 $g7$	8 $g7$	10 $g7$	mm
B	$4.8 \pm 0.2$	$4.8 \pm 0.2$	$4.8 \pm 0.2$	$4.8 \pm 0.2$	mm
D	12	14	16	18	mm
L <sub>min</sub>	6	9	12	15	mm
L <sub>max</sub>	20	20	20	20	mm
A* = diameter of connection shaft					
B = space between housing and shaft					
D = diameter clamping ring					
L = length of connection shaft					

<1> axial  
 <2> radial  
 <3> Cable radial  
 <4>  $\phi 6$  or  $\phi 8$   
 Cable bending radius R for flexible installation  $\geq 100$  mm  
 Cable bending radius R for fixed installation  $\geq 40$  mm  
 Tightening torque of set screw: 15 Ncm

Dimensions in mm

DIMENSIONED DRAWINGS (continued)

Torque support "F"

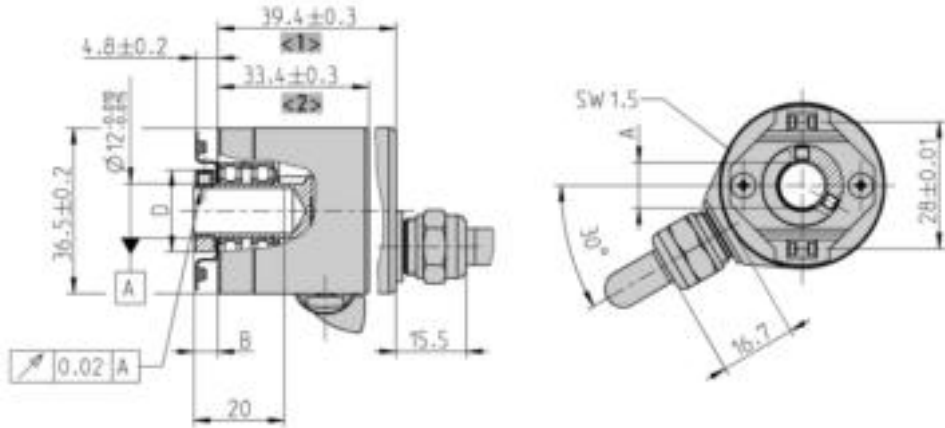

Dim.	Hollow shaft Ø				Unit
A	4 +0.01	6 +0.01	8 +0.01	10 +0.01	mm
A*	4 <sub>g7</sub>	10 <sub>g7</sub>	8 <sub>g7</sub>	10 <sub>g7</sub>	mm
B	4.8 ± 0.2	4.8 ± 0.2	4.8 ± 0.2	4.8 ± 0.2	mm
D	12	14	16	18	mm
L <sub>min</sub>	6	9	12	15	mm
L <sub>max</sub>	20	20	20	20	mm

A\* = diameter of connection shaft  
 B = space between housing and shaft  
 D = diameter clamping ring  
 L = length of connection shaft

<1> axial

<2> radial

Cable bending radius R for flexible installation ≥ 100 mm

Cable bending radius R for fixed installation ≥ 40 mm

Tightening torque of set screw: 15 Ncm

The hubshaft with tether (F) as torque support must be fixed by a cylindrical pin (2.4 mm Ø) at the machine side.

Dimensions in mm

Incremental

Hollow Shaft

ORDERING INFORMATION

Type	Number of pulses	Supply voltage <sup>1</sup>	Flange, Protection, Shaft <sup>3,4</sup>	Output <sup>2</sup>	Connection
<input type="checkbox"/>	<input type="checkbox"/>	<input type="checkbox"/>	<input type="checkbox"/>	<input type="checkbox"/>	<input type="checkbox"/>
<b>RI36-H</b>	<b>5 ... 3600</b>	<b>A</b> DC 5 V <b>E</b> DC 10 - 30 V	<b>F.30</b> Spring tether "F" with clamping ring front, IP64, 4 mm <b>F.31</b> Spring tether "F" with clamping ring front, IP64, 6 mm <b>F.3C</b> Spring tether "F" with clamping ring front, IP64, 8 mm <b>F.32</b> Spring tether "F" with clamping ring front, IP64, 10 mm <b>J.30</b> Spring tether "J" with clamping ring front, IP64, 4 mm <b>J.31</b> Spring tether "J" with clamping ring front, IP64, 6 mm <b>J.3C</b> Spring tether "J" with clamping ring front, IP64, 8 mm <b>J.32</b> Spring tether "J" with clamping ring front, IP64, 10 mm	<b>R</b> RS422 +Alarm <b>T</b> RS422 +Sense <b>K</b> Push-pull <b>I</b> Push-pull complementary	<b>A</b> Cable, axial <b>B</b> Cable, radial <b>E-I</b> M23 connector (Conin) at 1 m TPE cable, cw <b>E-D</b> M23 connector (Conin) at 1 m TPE cable, ccw

<sup>1</sup> DC 10 - 30 V only with push-pull

<sup>2</sup> Output code "K" and "I": short-circuit-proof

<sup>3</sup> Fixing of hubshaft with tether by cylindrical pin

<sup>4</sup> Fixing of hubshaft with tether by oblong hole

ORDERING INFORMATION

Selection of cable length

Versions with cable outlet (connection A, B, E or F) are available with various lengths of cable. To order your desired cable length, please add the respective code to the end of your ordering code. Further cable lengths on request.

Code	Cable length
without code	1.5 m
-D0	3 m
-F0	5 m
-K0	10 m
-P0	15 m
-U0	20 m
-V0	25 m

ACCESSORIES

see chapter "Accessories", starting page 322

## Incremental

## Hollow Shaft



- Through hollow shaft
- High accuracy by means of integrated flexible coupling
- Safe shaft mounting
- Applications: textile machines, motors, drives, copiers



### NUMBER OF PULSES

1 / 2 / 3 / 4 / 5 / 10 / 15 / 20 / 25 / 30 / 35 / 40 / 45 / 50 / 60 / 64 / 70 / 72 / 80 / **100** / 125 / 128 / 144 / 150 / 180 / 200 / **250** / 256 / 300 / 314 / 350 / 360 / 375 / 400 / 460 / 480 / **500** / 512 / 600 / 625 / 720 / 900 / **1000** / **1024** / **1250** / 1500 / 1600 / 1800 / 2000 / 2048 / **2500** / 3000 / 3480 / **3600** / 4000 / **4096** / **5000**

Other number of pulses on request

Preferably available versions are printed in bold type.

### TECHNICAL DATA mechanical

Housing diameter	58 mm
Shaft diameter	10 mm / 12 mm (Hubshaft)
Flange (Mounting of housing)	Synchro flange
Protection class shaft input (EN 60529)	IP64
Protection class housing (EN 60529)	IP64
	Ø 10 mm, tolerance g8 (-0.005 ... -0.027 mm), Ø 12 mm, tolerance g8 (-0.006 ... -0.033 mm)
Axial endplay of mounting shaft (hubshaft)	± 0.4 mm
Parallel endplay of mounting shaft	0.4 mm
Angular endplay of mounting shaft	1 °
Max. speed	max. 3000 rpm
Torque	≤ 2 Ncm
Moment of inertia	approx. 65 gcm <sup>2</sup> (10 mm shaft) approx. 95 gcm <sup>2</sup> (12 mm shaft)
Vibration resistance (DIN EN 60068-2-6)	10 g = 100 m/s <sup>2</sup> (10 ... 2000 Hz)
Shock resistance (DIN EN 60068-2-27)	100 g = 1000 m/s <sup>2</sup> (6 ms)
Operating temperature	-10 °C ... +70 °C
Storage temperature	-25 °C ... +85 °C
Material housing	Aluminum
Weight	approx. 210 g
Connection	Cable, radial

### TECHNICAL DATA electrical

General design	as per DIN VDE 0160, protection class III, contamination level 2, overvoltage class II
Supply voltage <sup>1</sup>	RS422 + Sense (T): DC 5 V ±10 % RS422 + Alarm (R): ± 10% DC 5 V or DC 10 - 30 V Push-pull (K), Push-pull antivalent (I): DC 10-30 V

## Incremental

## Hollow Shaft

### TECHNICAL DATA electrical (continued)

Max. current w/o load	40 mA (DC 5 V), 60 mA (DC 10 V), 30 mA (DC 24 V)
Max. pulse frequency	RS422: 300 kHz Push-pull: 200 kHz
Standard output versions <sup>2</sup>	RS422 + Alarm (R): A, B, N, $\bar{A}$ , $\bar{B}$ , $\bar{N}$ , $\overline{\text{Alarm}}$ RS422 + Sense (T): A, B, N, $\bar{A}$ , $\bar{B}$ , $\bar{N}$ , Sense Push-pull (K): A, B, N, $\overline{\text{Alarm}}$ Push-pull complementary (I): A, B, N, $\bar{A}$ , $\bar{B}$ , $\bar{N}$ , $\overline{\text{Alarm}}$
Pulse width error	± max. 25° electrical
Number of pulses	1 ... 5000
Pulse shape	Square wave
Pulse duty factor	1:1

<sup>1</sup> Pole protection with supply voltage DC 10 - 30 V

<sup>2</sup> Output description and technical data see chapter "Technical basics"

### ELECTRICAL CONNECTIONS Cable PVC

Connecting cable Colour	Lead Ø	Output RS422 T and R	push-pull K and I
red	0.5 mm <sup>2</sup>	DC 5/10 - 30 V	DC 10 - 30 V
red/yellow	0.14 mm <sup>2</sup>	Sense VCC	Sense VCC
white	0.14 mm <sup>2</sup>	Channel A	Channel A
white	0.14 mm <sup>2</sup>	Channel $\bar{A}$	Channel $\bar{A}$ <sup>1</sup>
green/brown	0.14 mm <sup>2</sup>	Channel B	Channel B
green/brown	0.14 mm <sup>2</sup>	Channel $\bar{B}$	Channel $\bar{B}$ <sup>1</sup>
yellow	0.14 mm <sup>2</sup>	Channel N	Channel N
yellow/brown	0.14 mm <sup>2</sup>	Channel $\bar{N}$	Channel $\bar{N}$ <sup>1</sup>
black	0.5mm <sup>2</sup>	GND	GND
black/yellow	0.14 mm <sup>2</sup>	$\overline{\text{Alarm}}$ /Sense GND <sup>2</sup>	$\overline{\text{Alarm}}$
screen <sup>3</sup>		screen <sup>3</sup>	screen <sup>3</sup>

<sup>1</sup> only push-pull complementary (I)

<sup>2</sup> depending on ordering code

<sup>3</sup> connected with encoder housing



### DIMENSIONED DRAWINGS

#### Synchro flange

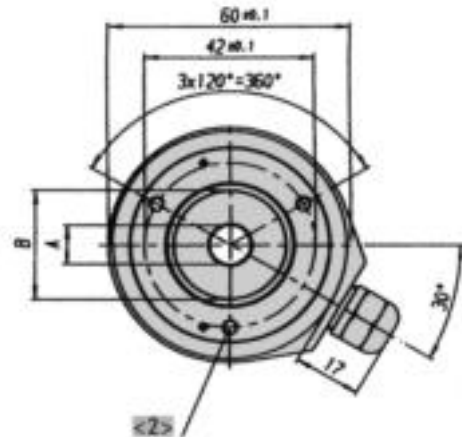
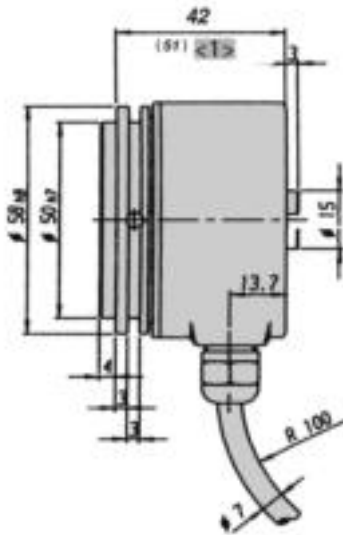

Required dimension of mounting shaft (g8)	Hollow shaft Ø (A)	B	Unit
-0.005 ... -0.027	10 *	28	mm
-0.006 ... -0.033	12 *	33	mm
* Tolerance H7 = 0 ... +0.018 mm			

<1> value in brackets with version DC 10 - 30 V, RS422

<2> mounting thread M4x5

Cable bending radius R for flexible installation  $\geq 100$  mm

Cable bending radius R for fixed installation  $\geq 40$  mm

Dimensions in mm

### ORDERING INFORMATION

Type	Number of pulses	Supply voltage <sup>1,2</sup>	Flange, Protection, Shaft	Output	Connection
<input type="checkbox"/>	<input type="checkbox"/>	<input type="checkbox"/>	<input type="checkbox"/>	<input type="checkbox"/>	<input type="checkbox"/>
<b>RI58-H</b>	<b>1 ... 5000</b>	<b>A</b> DC 5 V <b>E</b> DC 10 - 30 V	<b>S.42</b> Synchro, IP64, 10 mm <b>S.47</b> Synchro, IP64, 12 mm	<b>R</b> RS422 +Alarm <b>T</b> RS422 +Sense <b>K</b> Push-pull <b>I</b> Push-pull complementary	<b>B</b> PVC cable, radial

<sup>1</sup> DC 5 V: only with output "T", "R" available

<sup>2</sup> DC 10 - 30 V: only with output "K", "I", "R" available

## Incremental

## Hollow Shaft

## ORDERING INFORMATION

## Selection of cable length

Versions with cable outlet (connection A, B, E or F) are available with various lengths of cable. To order your desired cable length, please add the respective code to the end of your ordering code. Further cable lengths on request.

Code	Cable length
without code	1.5 m
-D0	3 m
-F0	5 m
-K0	10 m
-P0	15 m
-U0	20 m
-V0	25 m

## ACCESSORIES

see chapter "Accessories", starting page 322

# Standard Industrial Types RI 58-D / RI 58TD

## Incremental

## Hollow Shaft



Clamping shaft



Blind shaft

- Direct mounting without coupling
- Flexible hollow shaft design up to diameter 14 mm
- Through hollow shaft or as end shaft (blind shaft)
- Easy installation by means of clamping shaft or blind shaft
- Short overall length of 33 mm
- Fixing of flange by means of a stator coupling or set screw
- Various shaft versions
- Applications: actuators, motors
- Operating temperature up to 100 °C (RI 58TD)



### NUMBER OF PULSES

RI 58-D

1 / 2 / 3 / 4 / 5 / 10 / 20 / 25 / 30 / 35 / 40 / 45 / 50 / 60 / 64 / 70 / 72 / 80 / **100** / 125 / 128 / 144 / 150 / 180 / 200 / **250** / 256 / 300 / 314 / 350 / 360 / 375 / 400 / 460 / 480 / **500** / 512 / 600 / 625 / 720 / 900 / **1000** / **1024** / **1250** / 1500 / 1600 / 1800 / 2000 / 2048 / **2500** / 3000 / 3480 / **3600** / 4000 / **4096** / **5000**

Other number of pulses on request

Preferably available versions are printed in bold type.

RI 58TD

4 / 5 / 10 / 20 / 25 / 30 / 35 / 40 / 45 / 50 / 60 / 64 / 70 / 72 / 80 / **100** / 125 / 128 / 144 / 150 / 180 / 200 / **250** / 256 / 300 / 314 / 350 / 360 / 375 / 400 / 460 / 480 / **500** / 512 / 600 / 625 / 720 / 900 / **1000** / **1024** / **1250** / 1500 / 1600 / 1800 / 2000 / 2048 / **2500**

Other number of pulses on request

Preferably available versions are printed in bold type.

### TECHNICAL DATA mechanical

Housing diameter	58 mm
Shaft diameter <sup>1</sup>	10 mm / 12 mm (Through hollow shaft) 10 mm / 12 mm / 14 mm (Hubshaft)
Flange (Mounting of housing)	Synchro flange
Mounting of shaft	RI 58-D: Front clamping ring, Center bolt RI 58TD: Front clamping ring, Rear clamping ring, Center bolt
Protection class shaft input (EN 60529)	IP64
Protection class housing (EN 60529)	Through hollow shaft - D: IP64 Hubshaft - E,F: IP65
Shaft tolerance	Ø 10 mm, tolerance g8 (-0.005 ... -0.027 mm), Ø 12/ 14 mm, tolerance g8 (-0.006 ... -0.033 mm)
Max. speed	Hub shaft - E,F: max. 6000 rpm Through hollow shaft - D: max. 4000 rpm

# Standard Industrial Types RI 58-D / RI 58TD

## Incremental

## Hollow Shaft

### TECHNICAL DATA mechanical (continued)

Torque	≤ 1 Ncm (Hub shaft - E,F) ≤ 2 Ncm (Through hollow shaft - D)
Moment of inertia	approx. 35 gcm <sup>2</sup> (Hub shaft with clamping ring front - F) approx. 20 gcm <sup>2</sup> (Hub shaft, mounting with set screw - E) approx. 60 gcm <sup>2</sup> (Through hollow shaft with clamping ring front - D)
Vibration resistance (DIN EN 60068-2-6)	10 g = 100 m/s <sup>2</sup> (10 ... 2000 Hz)
Shock resistance (DIN EN 60068-2-27)	100 g = 1000 m/s <sup>2</sup> (6 ms)
Operating temperature	RI 58-D: -10 °C ... +70 °C RI 58TD: -25 °C ... +100 °C
Storage temperature	-25 °C ... +85 °C
Material housing	Aluminum
Weight	approx. 170 g with hubshaft (E,F), approx. 190 g with through hollow shaft (D)
Connection <sup>2</sup>	Cable, axial or radial M23 connector (Conin), radial

<sup>1</sup> Other shaft diameters on request

<sup>2</sup> Standard cable length: 1.5 m cable, other cable length on request (only RI 58TD)

### TECHNICAL DATA electrical

General design	as per DIN VDE 0160, protection class III, contamination level 2, overvoltage class II
Supply voltage <sup>1</sup>	RS422 + Sense (T): DC 5 V ±10 % RS422 + Alarm (R): ± 10% DC 5 V or DC 10 - 30 V Push-pull (K), Push-pull antivalent (I): DC 10-30 V
Max. current w/o load	40 mA (DC 5 V), 60 mA (DC 10 V), 30 mA (DC 24 V)
Max. pulse frequency	RS422: 300 kHz Push-pull: 200 kHz
Standard output versions <sup>2</sup>	RS422 + Alarm (R): A, B, N, $\bar{A}$ , $\bar{B}$ , $\bar{N}$ , $\overline{Alarm}$ RS422 + Sense (T): A, B, N, $\bar{A}$ , $\bar{B}$ , $\bar{N}$ , Sense Push-pull (K): A, B, N, $\overline{Alarm}$ Push-pull complementary (I): A, B, N, $\bar{A}$ , $\bar{B}$ , $\bar{N}$ , $\overline{Alarm}$
Pulse width error	± max. 25° electrical
Number of pulses	1 ... 5000
Alarm output	NPN-O.C., max. 5 mA
Pulse shape	Square wave
Pulse duty factor	1:1

<sup>1</sup> With push-pull (K): pole protection

<sup>2</sup> Output description and technical data see chapter "Technical basics"

**Incremental**

**Hollow Shaft**

**MOUNTING NECESSITIES**

In order to be able to compensate an axial and radial misalignment of the shaft, the encoder flange must not be fixed rigidly. Fix the flanges by means of a stator coupling (e.g. hubshaft with tether) as torque support (see "Accessories") or by means of a cylindrical pin:

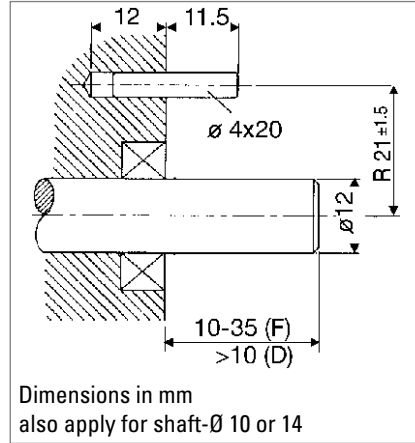

Mounting = D, F (Clamping ring)

Preparation of the machine flange <sup>1</sup>  
**(all mounting versions):**

In the machine flange a straight pin must be installed (diameter 4x16 resp. 4x20, DIN 6325).

This pin is required as a torque support.

<sup>1</sup> Or as an option: stator coupling as torque support

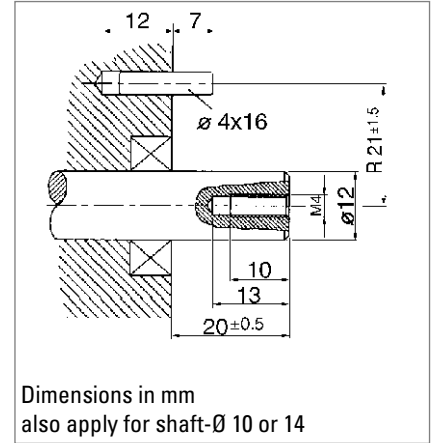

Mounting = E (mounting with center screw)

Preparation of the drive shaft  
**(only in mounting = E):**

The drive shaft must be provided with a threaded bore M 4 x 10:

This bore accepts the fastening screw of the shaft encoder.

**ELECTRICAL CONNECTIONS**  
Cable PVC

Cable PVC Colour	Output circuit			
	RS422 + Sense (T)	RS422 + Alarm (R)	push-pull (K)	push-pull complementary (I)
white	Channel A	Channel A	Channel A	Channel A
white/brown	Channel $\bar{A}$	Channel $\bar{A}$		Channel $\bar{A}$
green	Channel B	Channel B	Channel B	Channel B
green/brown	Channel $\bar{B}$	Channel $\bar{B}$		Channel $\bar{B}$
yellow	Channel N	Channel N	Channel N	Channel N
yellow/brown	Channel $\bar{N}$	Channel $\bar{N}$		Channel $\bar{N}$
yellow/black	Sense GND	$\bar{A}larm$	$\bar{A}larm$	$\bar{A}larm$
yellow/red	Sense V <sub>CC</sub>	Sense V <sub>CC</sub>		Sense V <sub>CC</sub>
red	DC 5 V	DC 5 / 10 - 30 V	DC 10 - 30 V	DC 10 - 30 V
black	GND	GND	GND	GND
Cable screen <sup>1</sup>	Cable screen <sup>1</sup>	Cable screen <sup>1</sup>	Cable screen <sup>1</sup>	Cable screen <sup>1</sup>

<sup>1</sup> connected with encoder housing

**Incremental**

**Hollow Shaft**

**ELECTRICAL CONNECTIONS**  
Cable TPE

Cable TPE Colour	Output circuit			
	RS422 + Sense (T)	RS422 + Alarm (R)	push-pull (K)	push-pull complementary (I)
brown	Channel A	Channel A	Channel A	Channel A
green	Channel $\bar{A}$	Channel $\bar{A}$		Channel $\bar{A}$
grey	Channel B	Channel B	Channel B	Channel B
pink	Channel $\bar{B}$	Channel $\bar{B}$		Channel $\bar{B}$
red	Channel N	Channel N	Channel N	Channel N
black	Channel $\bar{N}$	Channel $\bar{N}$		Channel $\bar{N}$
violet (white) <sup>1</sup>	Sense GND	$\bar{Alarm}$	$\bar{Alarm}$	$\bar{Alarm}$
blue	Sense V <sub>CC</sub>	Sense V <sub>CC</sub>		Sense V <sub>CC</sub>
brown/green	DC 5 V	DC 5 / 10 - 30 V	DC 10 - 30 V	DC 10 - 30 V
white/green	GND	GND	GND	GND
Cable screen <sup>2</sup>	Cable screen <sup>2</sup>	Cable screen <sup>2</sup>	Cable screen <sup>2</sup>	Cable screen <sup>2</sup>

<sup>1</sup> white with RS422 + Sense (T)

<sup>2</sup> connected with encoder housing

**ELECTRICAL CONNECTIONS**  
M23 connector (Conin), 12 pole

Pin	RS422 + Sense (T)	RS422 + Alarm (R)	push-pull (K)	push-pull complementary (I)
1	Channel $\bar{B}$	Channel $\bar{B}$	N.C.	Channel $\bar{B}$
2	Sense V <sub>CC</sub>	Sense V <sub>CC</sub>	N.C.	Sense V <sub>CC</sub>
3	Channel N	Channel N	Channel N	Channel N
4	Channel $\bar{N}$	Channel $\bar{N}$	N.C.	Channel $\bar{N}$
5	Channel A	Channel A	Channel A	Channel A
6	Channel $\bar{A}$	Channel $\bar{A}$	N.C.	Channel $\bar{A}$
7	N.C.	$\bar{Alarm}$	$\bar{Alarm}$	$\bar{Alarm}$
8	Channel B	Channel B	Channel B	Channel B
9	N.C. <sup>1</sup>	N.C. <sup>1</sup>	N.C. <sup>1</sup>	N.C. <sup>1</sup>
10	GND	GND	GND	GND
11	Sense GND	N.C.	N.C.	N.C.
12	DC 5 V	DC 5/10 - 30 V	DC 10 - 30 V	DC 10 - 30 V

<sup>1</sup> screen for cable with CONIN connector

# Standard Industrial Types RI 58-D / RI 58TD Incremental Hollow Shaft

## DIMENSIONED DRAWINGS

Mounting F: Hubshaft with clamping ring front

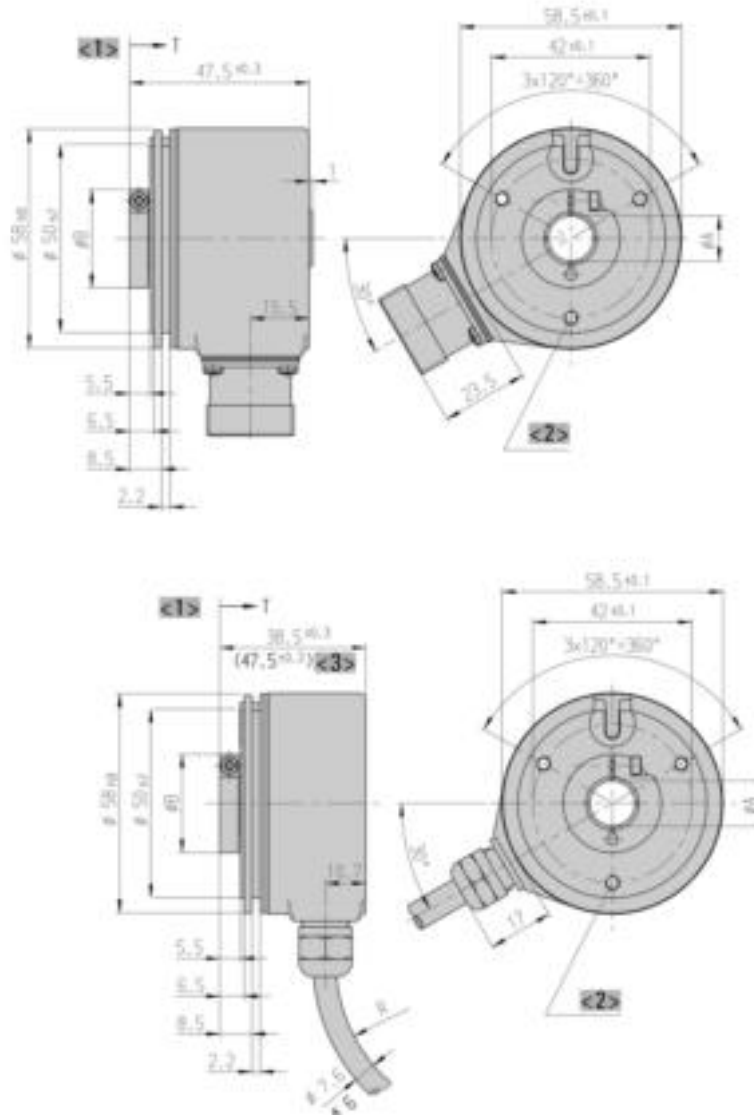

Dim.	Hollow shaft Ø			Unit
A	10 <sup>H7</sup>	12 <sup>H7</sup>	14 <sup>H7</sup>	mm
A*	10 <sup>g8</sup>	12 <sup>g8</sup>	14 <sup>g8</sup>	mm
B	26	28	30	mm
T	33.5	33.5	22.5	mm

A\* = diameter of connection shaft

- <1> View turned 60°
  - <2> mounting thread M4x5
  - <3> value in brackets with version DC 10 - 30 V, RS422
- Cable bending radius R for flexible installation ≥ 100 mm  
Cable bending radius R for fixed installation ≥ 40 mm

Dimensions in mm

# Standard Industrial Types **RI 58-D / RI 58TD**

## Incremental Hollow Shaft

**DIMENSIONED DRAWINGS (continued)**

**Mounting D: Through hollow shaft with clamping ring front**

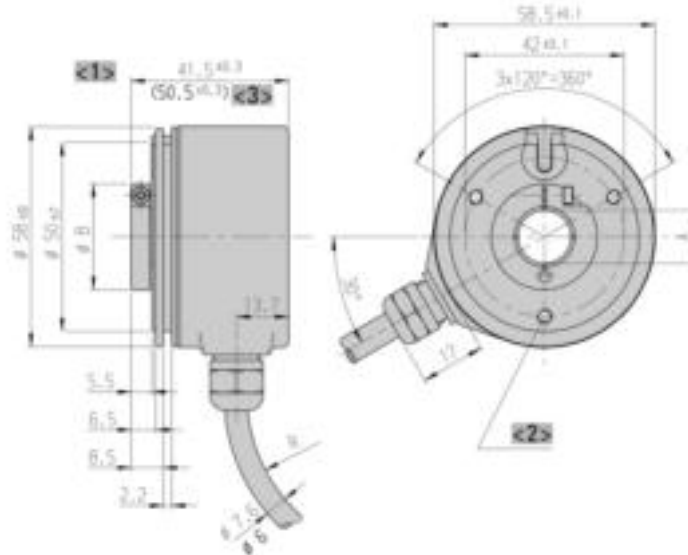

Dim.	Hollow shaft $\varnothing$		Unit
A	10 <sup>H7</sup>	12 <sup>H7</sup>	mm
A*	10 <sub>g8</sub>	12 <sub>g8</sub>	mm
B	26	28	mm

A\* = diameter of connection shaft

- <1> View turned 60°
  - <2> mounting thread M4x5
  - <3> value in brackets with version DC 10 - 30 V, RS422
- Cable bending radius R for flexible installation  $\geq 100$  mm  
 Cable bending radius R for fixed installation  $\geq 40$  mm

Dimensions in mm



# Standard Industrial Types RI 58-D / RI 58TD

## Incremental Hollow Shaft

DIMENSIONED DRAWINGS (continued)

Mounting H optional: Through hollow shaft with clamping ring rear on request

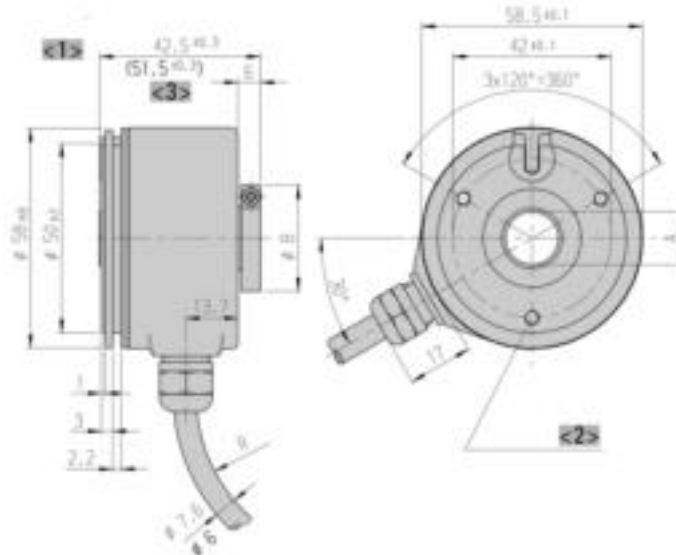

Dim.	Hollow shaft Ø		Unit
A	10 <sup>H7</sup>	12 <sup>H7</sup>	mm
A*	10 <sup>g8</sup>	12 <sup>g8</sup>	mm
B	26	28	mm

A\* = diameter of connection shaft

<1> View turned 60°

<2> mounting thread M4x5

<3> value in brackets with version DC 10 - 30 V, RS422

Cable bending radius R for flexible installation ≥ 100 mm

Cable bending radius R for fixed installation ≥ 40 mm

Dimensions in mm

# Standard Industrial Types RI 58-D / RI 58TD

## Incremental Hollow Shaft

DIMENSIONED DRAWINGS (continued)

Mounting E: Hubshaft, mounting with center screw

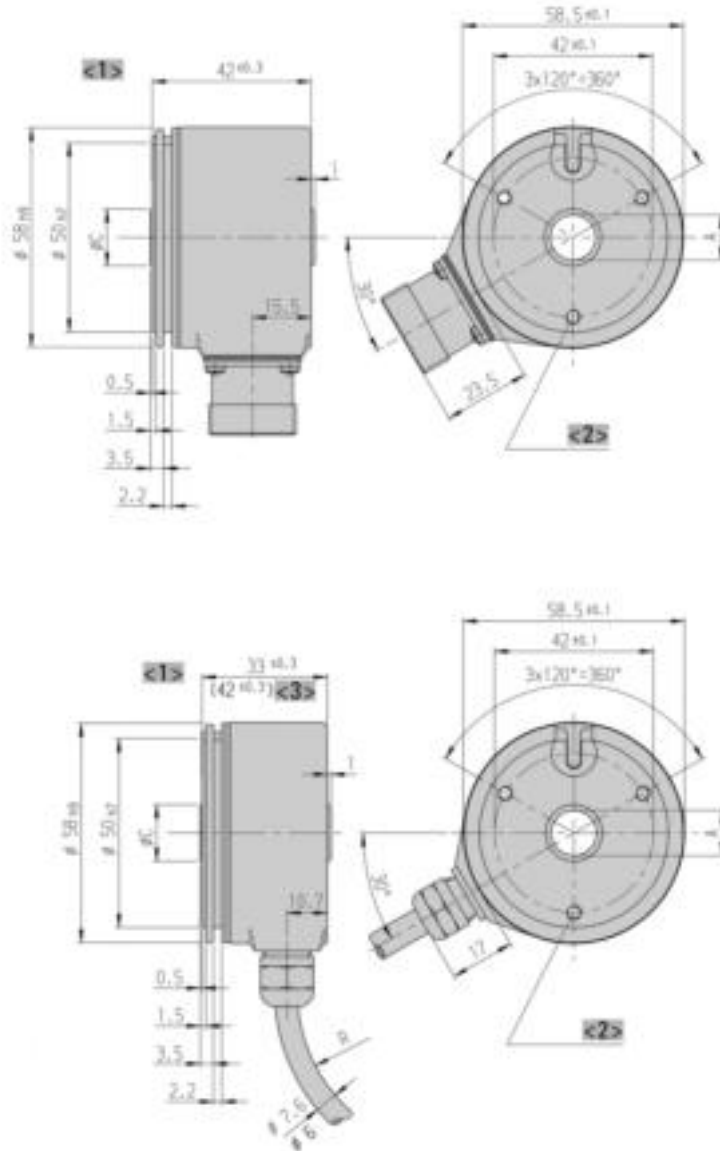

Dim.	Hollow shaft Ø			Unit
A	10 <sup>H7</sup>	12 <sup>H7</sup>	14 <sup>H7</sup>	mm
A*	10 <sup>g8</sup>	12 <sup>g8</sup>	14 <sup>g8</sup>	mm
C	15	15	17	mm
T	18±0.5	18±0.5	18±0.5	mm

A\* = diameter of connection shaft  
T = length of custom shaft in encoder

<1> View turned 60°  
 <2> mounting thread M4x5  
 <3> value in brackets with version DC 10 - 30 V, RS422  
 Cable bending radius R for flexible installation ≥ 100 mm  
 Cable bending radius R for fixed installation ≥ 40 mm

Dimensions in mm

# Standard Industrial Types **RI 58-D / RI 58TD**

## Incremental Hollow Shaft

### ORDERING INFORMATION

Type	Number of pulses	Supply voltage <sup>1,2</sup>	Flange, Protection, Shaft <sup>3,4,5</sup>	Output	Connection
□	□	□	□	□	□
<b>RI58-D</b> <b>RI58TD</b>	<b>1 ... 5000</b>	<b>A</b> DC 5 V <b>E</b> DC 10 - 30 V	<b>D.32</b> Through hollow shaft with clamping ring front, IP64, 10 mm <b>D.37</b> Through hollow shaft with clamping ring front, IP64, 12 mm <b>E.42</b> Hubshaft, mounting with set screw, IP64, 10 mm <b>E.47</b> Hubshaft, mounting with set screw, IP64, 12 mm <b>E.49</b> Hubshaft, mounting with set screw, IP64, 14 mm <b>F.42</b> Spring tether, IP64, hubshaft 10 mm, mounting with clamping ring front <b>F.47</b> Spring tether, IP64, hubshaft 12 mm, mounting with clamping ring front <b>F.49</b> Spring tether, IP64, hubshaft 14 mm, mounting with clamping ring front	<b>R</b> RS422 +Alarm <b>T</b> RS422 +Sense <b>K</b> Push-pull <b>I</b> Push-pull complementary	<b>B</b> PVC cable, radial <b>F</b> TPE cable, radial <b>D</b> M23 connector (Conin), 12 pole, radial, cw <b>H</b> M23 connector (Conin), 12 pole, radial, ccw

<sup>1</sup> DC 5 V: only with output "T", "R" available

<sup>2</sup> DC 10 - 30 V: only with output "K", "I", "R" available

<sup>3</sup> Mounting (flange) code "D" only with connection code "B", "F" (cable)

<sup>4</sup> Mounting (flange) code "E", "F" only with connection code "D", "H" (M23 connector)

<sup>5</sup> IP67 on cover with connector only if IP67 mating connector mounted properly.

### ORDERING INFORMATION

#### Selection of cable length

Versions with cable outlet (connection A, B, E or F) are available with various lengths of cable. To order your desired cable length, please add the respective code to the end of your ordering code. Further cable lengths on request.

Code	Cable length
without code	1.5 m
-D0	3 m
-F0	5 m
-K0	10 m
-P0	15 m
-U0	20 m
-V0	25 m

### ACCESSORIES

see chapter "Accessories", starting page 322

# Standard Industrial Types RI 58-G / RI 58TG

## Incremental

## Hollow Shaft



- Direct mounting without coupling
- Through hollow shaft Ø 14 mm and 15 mm
- Easy installation by means of clamping ring
- Fixing of flange by means of a stator coupling or set screw
- Applications: actuators, motors



<b>NUMBER OF PULSES</b>	RI 58-G	50 / 360 / 500 / 1000 / 1024 / 2000 / 2048 / 2500 / 3600 / 4096 / 5000
<b>NUMBER OF PULSES</b>	RI 58TG	50 / 360 / 500 / 1000 / 1024 / 2000 / 2048 / 2500

### TECHNICAL DATA mechanical

Housing diameter	58 mm
Shaft diameter	14 mm / 15 mm (Through hollow shaft)
Flange (Mounting of housing)	Synchro flange
Mounting of shaft	Front clamping ring, Rear clamping ring
Protection class shaft input (EN 60529)	IP64
Protection class housing (EN 60529)	IP64
Shaft tolerance	Ø 14/ 15 mm, tolerance g8
Max. speed	max. 4000 rpm
Torque	≤ 2 Ncm
Moment of inertia	approx. 60 gcm <sup>2</sup>
Vibration resistance (DIN EN 60068-2-6)	10 g = 100 m/s <sup>2</sup> (10 ... 2000 Hz)
Shock resistance (DIN EN 60068-2-27)	100 g = 1000 m/s <sup>2</sup> (6 ms)
Operating temperature	RI 58-G: -10 °C ... +70 °C RI 58TG: -10 °C ... +100 °C
Storage temperature	-25 °C ... +85 °C
Material housing	Aluminum
Weight	approx. 210 g
Connection	Cable, radial

### TECHNICAL DATA electrical

General design	as per DIN VDE 0160, protection class III, contamination level 2, overvoltage class II
Supply voltage <sup>1</sup>	RS422 + Sense (T): DC 5 V ±10 % RS422 + Alarm (R): ± 10% DC 5 V or DC 10 - 30 V Push-pull (K), Push-pull antivalent (I): DC 10-30 V
Max. current w/o load	40 mA (DC 5 V), 60 mA (DC 10 V), 30 mA (DC 24 V)
Max. pulse frequency	RS422: 300 kHz Push-pull: 200 kHz
Standard output versions <sup>2</sup>	RS422 + Alarm (R): A, B, N, $\bar{A}$ , $\bar{B}$ , $\bar{N}$ , $\overline{\text{Alarm}}$ RS422 + Sense (T): A, B, N, $\bar{A}$ , $\bar{B}$ , $\bar{N}$ , Sense Push-pull (K): A, B, N, $\overline{\text{Alarm}}$ Push-pull complementary (I): A, B, N, $\bar{A}$ , $\bar{B}$ , $\bar{N}$ , $\overline{\text{Alarm}}$

## Incremental

## Hollow Shaft

### TECHNICAL DATA electrical (continued)

Pulse width error	± max. 25° electrical
Number of pulses	50 ... 2500
Alarm output	NPN-O.C., max. 5 mA
Pulse shape	Square wave
Pulse duty factor	1:1

<sup>1</sup> With push-pull (K): pole protection

<sup>2</sup> Output description and technical data see chapter "Technical basics"

### MOUNTING NECESSITIES

In order to be able to compensate an axial and radial misalignment of the shaft, the encoder flange must not be fixed rigidly. Fix the flanges by means of a stator coupling (e.g. hubshaft with tether) as torque support (see "Accessories") or by means of a cylindrical pin:

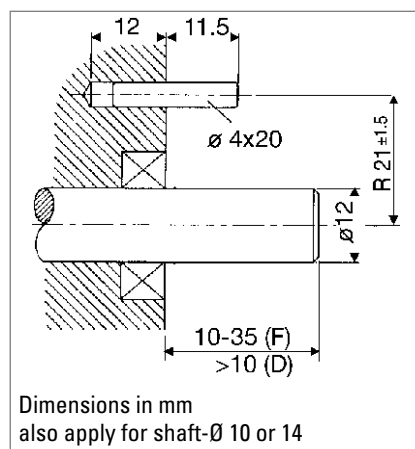

Mounting = D, F (Clamping ring)

#### Preparation of the machine flange <sup>1</sup>

**(all mounting versions):**

In the machine flange a straight pin must be installed (diameter 4x16 resp. 4x20, DIN 6325).

This pin is required as a torque support.

<sup>1</sup> Or as an option: stator coupling as torque support

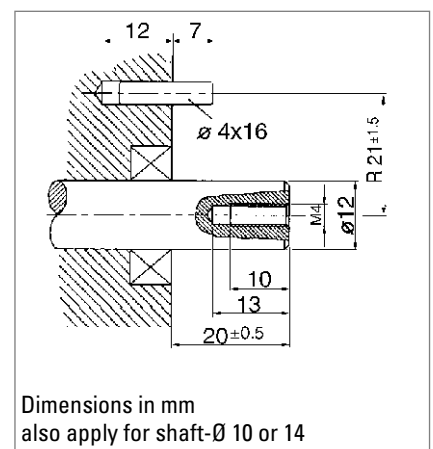

Mounting = E (mounting with center screw)

#### Preparation of the drive shaft

**(only in mounting = E):**

The drive shaft must be provided with a threaded bore M 4 x 10:

This bore accepts the fastening screw of the shaft encoder.

**Incremental**

**Hollow Shaft**

**ELECTRICAL CONNECTIONS**

**Cable PVC**

Cable PVC Colour	Output circuit			
	RS422 + Sense (T)	RS422 + Alarm (R)	push-pull (K)	push-pull complementary (I)
white	Channel A	Channel A	Channel A	Channel A
white/brown	Channel $\bar{A}$	Channel $\bar{A}$		Channel $\bar{A}$
green	Channel B	Channel B	Channel B	Channel B
green/brown	Channel $\bar{B}$	Channel $\bar{B}$		Channel $\bar{B}$
yellow	Channel N	Channel N	Channel N	Channel N
yellow/brown	Channel $\bar{N}$	Channel $\bar{N}$		Channel $\bar{N}$
yellow/black	Sense GND	$\bar{\text{Alarm}}$	$\bar{\text{Alarm}}$	$\bar{\text{Alarm}}$
yellow/red	Sense $V_{CC}$	Sense $V_{CC}$		Sense $V_{CC}$
red	DC 5 V	DC 5 / 10 - 30 V	DC 10 - 30 V	DC 10 - 30 V
black	GND	GND	GND	GND
Cable screen <sup>1</sup>	Cable screen <sup>1</sup>	Cable screen <sup>1</sup>	Cable screen <sup>1</sup>	Cable screen <sup>1</sup>

<sup>1</sup> connected with encoder housing

**ELECTRICAL CONNECTIONS**

**Cable TPE**

Cable TPE Colour	Output circuit			
	RS422 + Sense (T)	RS422 + Alarm (R)	push-pull (K)	push-pull complementary (I)
brown	Channel A	Channel A	Channel A	Channel A
green	Channel $\bar{A}$	Channel $\bar{A}$		Channel $\bar{A}$
grey	Channel B	Channel B	Channel B	Channel B
pink	Channel $\bar{B}$	Channel $\bar{B}$		Channel $\bar{B}$
red	Channel N	Channel N	Channel N	Channel N
black	Channel $\bar{N}$	Channel $\bar{N}$		Channel $\bar{N}$
violet (white) <sup>1</sup>	Sense GND	$\bar{\text{Alarm}}$	$\bar{\text{Alarm}}$	$\bar{\text{Alarm}}$
blue	Sense $V_{CC}$	Sense $V_{CC}$		Sense $V_{CC}$
brown/green	DC 5 V	DC 5 / 10 - 30 V	DC 10 - 30 V	DC 10 - 30 V
white/green	GND	GND	GND	GND
Cable screen <sup>2</sup>	Cable screen <sup>2</sup>	Cable screen <sup>2</sup>	Cable screen <sup>2</sup>	Cable screen <sup>2</sup>

<sup>1</sup> white with RS422 + Sense (T)

<sup>2</sup> connected with encoder housing

# Standard Industrial Types RI 58-G / RI 58TG Incremental Hollow Shaft

## DIMENSIONED DRAWINGS

Mounting D: Through hollow shaft with clamping ring front

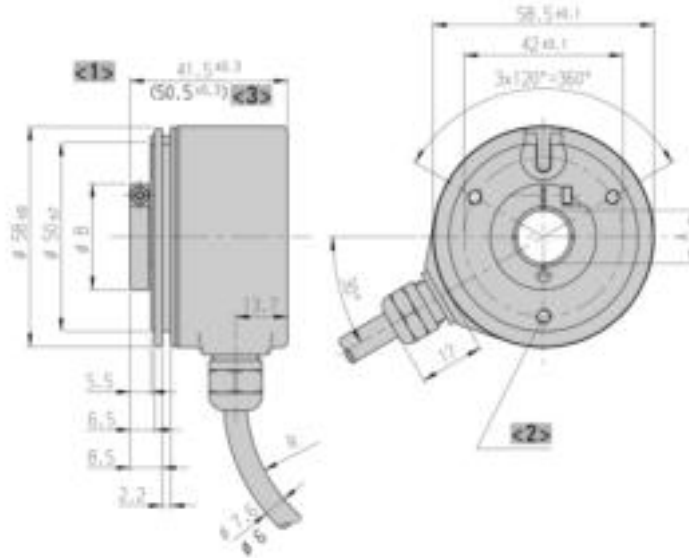

Dim.	Hollow shaft Ø		Unit
A	14 <sup>H7</sup>	15 <sup>H7</sup>	mm
A*	14 <sup>g8</sup>	15 <sup>g8</sup>	mm
B	30	30	mm

A\* = diameter of connection shaft

- <1> View turned 60°
  - <2> mounting thread M4x5
  - <3> value in brackets with version DC 10 - 30 V, RS422
- Cable bending radius R for flexible installation ≥ 100 mm  
Cable bending radius R for fixed installation ≥ 40 mm

Dimensions in mm

# Standard Industrial Types RI 58-G / RI 58TG

## Incremental

## Hollow Shaft

### DIMENSIONED DRAWINGS (continued)

Mounting H optional: Through hollow shaft with clamping ring rear on request

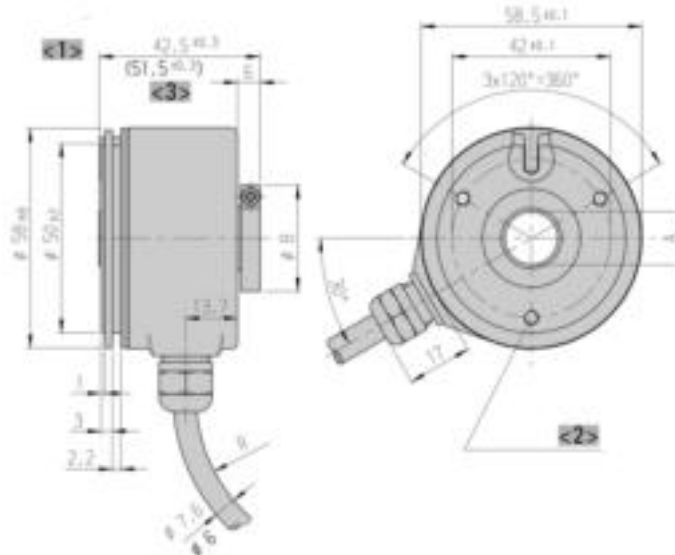

Dim.	Hollow shaft Ø		Unit
A	14 <sup>H7</sup>	15 <sup>H7</sup>	mm
A*	14 <sup>g8</sup>	15 <sup>g8</sup>	mm
B	30	30	mm

A\* = diameter of connection shaft

<1> View turned 60°

<2> mounting thread M4x5

<3> value in brackets with version DC 10 - 30 V, RS422

Cable bending radius R for flexible installation ≥ 100 mm

Cable bending radius R for fixed installation ≥ 40 mm

Dimensions in mm

### ORDERING INFORMATION

Type	Number of pulses	Supply voltage <sup>1,2</sup>	Flange, Protection, Shaft <sup>3</sup>	Output	Connection
<input type="checkbox"/>	<input type="checkbox"/>	<input type="checkbox"/>	<input type="checkbox"/>	<input type="checkbox"/>	<input type="checkbox"/>
<b>RI58-G</b> <b>RI58TG</b>	RI 58-G: <b>50 ...</b> <b>2500</b> RI 58TG: <b>50 ...</b> <b>5000</b>	<b>A</b> DC 5 V <b>E</b> DC 10 - 30 V	<b>D.39</b> Through hollow shaft with clamping ring front, IP64, 14 mm <b>D.3D</b> Through hollow shaft with clamping ring front, IP64, 15 mm <b>H.39</b> Through hollow shaft with clamping ring rear, IP64, 14 mm <b>H.3D</b> Through hollow shaft with clamping ring rear, IP64, 15 mm	<b>R</b> RS422 +Alarm (RI 58-G) <b>T</b> RS422 +Sense <b>K</b> Push-pull <b>I</b> Push-pull complementary <b>R</b> RS422 +Alarm +Sense (RI 58TG)	<b>B</b> PVC cable, radial <b>F</b> TPE cable, radial <b>D</b> M23 connector (Conin), 12 pole, radial, cw (RI 58-G) <b>H</b> M23 connector (Conin), 12 pole, radial, ccw (RI 58-G)

<sup>1</sup> DC 5 V: only with output "T", "R" available

<sup>2</sup> DC 10 - 30 V: only with output "K", "I", "R" available

<sup>3</sup> IP67 on cover with connector only if IP67 mating connector mounted properly.



**Incremental****Hollow Shaft****ORDERING INFORMATION**  
**Selection of cable length**

Versions with cable outlet (connection A, B, E or F) are available with various lengths of cable. To order your desired cable length, please add the respective code to the end of your ordering code. Further cable lengths on request.

<b>Code</b>	<b>Cable length</b>
without code	1.5 m
-D0	3 m
-F0	5 m
-K0	10 m
-P0	15 m
-U0	20 m
-V0	25 m

## Incremental

## Hollow Shaft



### NUMBER OF PULSES

- Incremental hollow shaft encoder
- Up to 10 000 ppr
- Through hollow shaft and hubshaft up to 12 mm (14 mm optional)
- Optimized stator coupling
- Applications: Feedback for asynchronous motors, industrial applications



1 / 2 / 3 / 4 / 10 / 20 / 25 / 30 / 40 / 45 / 50 / 60 / 64 / 70 / 72 / 80 / **100** / 125 / 128 / 144 / 150 / 180 / 200 / **250** / 256 / 300 / 314 / 350 / 360 / 375 / 400 / 460 / 480 / **500** / 512 / 600 / 625 / 720 / 900 / **1000** / **1024** / **1250** / 1500 / 1600 / 1800 / 2000 / 2048 / 2500 / 3000 / 3480 / **3600** / 4000 / **4096** / **5000** / **7854** / **10000**

Preferably available versions are printed in bold type.

### TECHNICAL DATA mechanical

Housing diameter	58 mm
Shaft diameter	6 mm / 10 mm / 12 mm (Hubshaft) 6 mm / 10 mm / 12 mm (Through hollow shaft)
Flange (Mounting of housing)	Tether
Mounting of shaft	Set screw, Front clamping ring, Rear clamping ring, Clamping ring with set screw
Protection class shaft input (EN 60529)	IP64
Protection class housing (EN 60529)	Through hollow shaft - D: IP64 Hubshaft - F: IP67
Axial endplay of mounting shaft (hubshaft)	± 1.5 mm
Radial runout of mating shaft (hubshaft)	± 0.2 mm
Max. speed	Hub shaft: max. 4000 rpm Through hollow shaft: max. 6000 rpm
Vibration resistance (DIN EN 60068-2-6)	100 m/s <sup>2</sup>
Shock resistance (DIN EN 60068-2-27)	1000 m/s <sup>2</sup>
Operating temperature	-10 °C ... +70 °C
Storage temperature	-25 °C ... +85 °C
Material shaft	Stainless Steel
Material housing	Aluminum
Weight	approx. 180 g
Connection	Cable, radial M23 connector (Conin), 12 pole, radial

### TECHNICAL DATA electrical

General design	as per DIN VDE 0160, protection class III, contamination level 2, overvoltage class II
Supply voltage <sup>1</sup>	RS422 + Sense (T): DC 5 V ±10 % RS422 + Alarm (R): ± 10% DC 5 V or DC 10 - 30 V Push-pull (K), Push-pull antivalent (I): DC 10-30 V
Max. current w/o load	40 mA (DC 5 V), 60 mA (DC 10 V), 30 mA (DC 24 V)

## Incremental

## Hollow Shaft

### TECHNICAL DATA electrical (continued)

Standard output versions <sup>2,3</sup>

RS422 + Alarm (R): A, B, N,  $\bar{A}$ ,  $\bar{B}$ ,  $\bar{N}$ ,  $\bar{Alarm}$   
 RS422 + Sense (T): A, B, N,  $\bar{A}$ ,  $\bar{B}$ ,  $\bar{N}$ , Sense  
 Push-pull (K): A, B, N,  $\bar{Alarm}$   
 Push-pull complementary (I): A, B, N,  $\bar{A}$ ,  $\bar{B}$ ,  $\bar{N}$ ,  $\bar{Alarm}$

Number of pulses

1 ... 10 000

<sup>1</sup> Pole protection with supply voltage DC 10 - 30 V

<sup>2</sup> Output code "K" and "I": short-circuit-proof

<sup>3</sup> Output description and technical data see chapter "Technical basics"

### DIMENSIONED DRAWINGS

#### Hubshaft

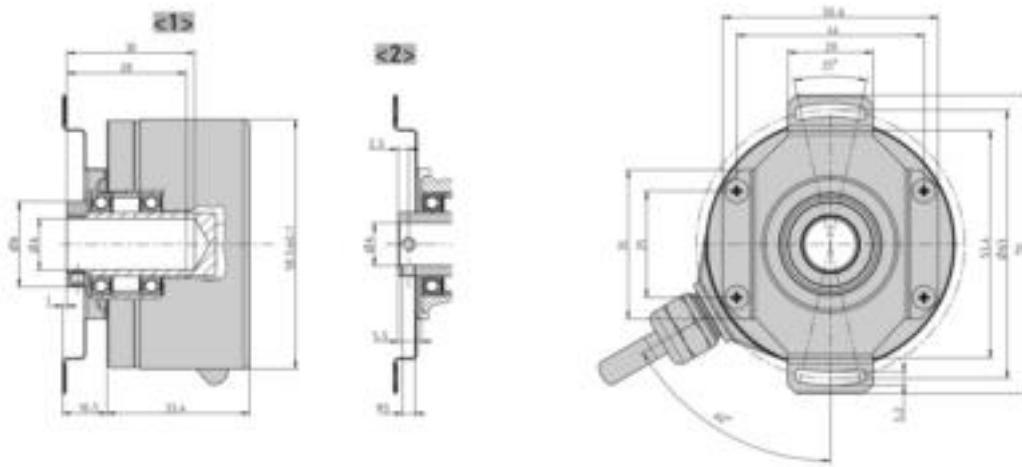

Dim.	Hollow shaft $\varnothing$		Unit
A	10 <sup>-0.002/+0.008</sup>	12 <sup>-0.002/+0.008</sup>	mm
A*	10 <sub>g7</sub>	12 <sub>g7</sub>	mm
B		20	mm
L <sub>min</sub>	15.5	17.5	mm
L <sub>max</sub>	28	28	mm
A* = diameter of connection shaft			
L = length of connection shaft			

<1>  $\varnothing A > 10$  mm

<2>  $\varnothing A \leq 10$  mm

Cable bending radius R for flexible installation  $\geq 100$  mm

Cable bending radius R for fixed installation  $\geq 40$  mm

Dimensions in mm

DIMENSIONED DRAWINGS (continued)

**Through hollow shaft**

Dim.	Hollow shaft Ø		Unit
A	10 +0.012	12 +0.012	mm
A*	10 g7	12 g7	mm
B	18	20	mm

A\* = diameter of connection shaft

Cable bending radius R for flexible installation ≥ 100 mm  
Cable bending radius R for fixed installation ≥ 40 mm

Dimensions in mm

ORDERING INFORMATION

Type	Number of pulses	Supply voltage <sup>1,2</sup>	Flange, Protection, Shaft <sup>4</sup>	Output	Connection <sup>3</sup>
<input type="checkbox"/>	<input type="checkbox"/>	<input type="checkbox"/>	<input type="checkbox"/>	<input type="checkbox"/>	<input type="checkbox"/>
<b>RI58-F</b>	<b>1 ... 10000</b>	<b>A</b> DC 5 V <b>E</b> DC 10 - 30 V	<b>B.32</b> Spring tether, IP64, through hollow shaft, 10 mm, mounting with clamping ring front and rear <b>B.37</b> Spring tether, IP64, through hollow shaft, 12 mm, mounting with clamping ring front and rear <b>F.41</b> Spring tether, IP64, hubshaft 6 mm, mounting with set screw <b>F.42</b> Spring tether, IP64, hubshaft 10 mm, mounting with set screw <b>F.47</b> Spring tether, IP64, hubshaft 12 mm, mounting with ring with clamping set screw	<b>R</b> RS422 +Alarm <b>T</b> RS422 +Sense <b>K</b> HTL <b>I</b> HTL complementary	<b>B</b> PVC cable, radial <b>F</b> TPE cable, radial <b>D</b> M23 connector (Conin), 12 pole, radial, cw <b>H</b> M23 connector (Conin), 12 pole, radial, ccw

<sup>1</sup> DC 5 V only with output T, R, K

<sup>2</sup> DC 10 - 30 V only with output K, I

<sup>3</sup> Connection code "D", "H" (M23 connector) only with hubshaft

<sup>4</sup> IP67 on cover with connector only if IP67 mating connector mounted properly.

**Incremental****Hollow Shaft****ORDERING INFORMATION**  
**Selection of cable length**

Versions with cable outlet (connection A, B, E or F) are available with various lengths of cable. To order your desired cable length, please add the respective code to the end of your ordering code. Further cable lengths on request.

<b>Code</b>	<b>Cable length</b>
without code	1.5 m
-D0	3 m
-F0	5 m
-K0	10 m
-P0	15 m
-U0	20 m
-V0	25 m

**ACCESSORIES**

see chapter "Accessories", starting page 322

## Incremental

## Hollow Shaft



## NUMBER OF PULSES

- Through hollow shaft  $\varnothing$  15 bis 42 mm
- Outside diameter only 76 mm
- Easy installation by means of clamping ring front or rear
- Operating temperature up to 100 °C
- Applications: motors, printing machines, lifts



50 / 100 / 128 / 250 / 256 / 300 / 314 / 360 / 500 / 600 / 720 / 900 / 1000 / 1024 / 1250 / 1500 / 2048 / 2500 / 3072 / 4096 / 5000 / 9000 / 10000

Other number of pulses on request

**TECHNICAL DATA**  
**mechanical**

Housing diameter	76 mm
Shaft diameter	15 mm / 16 mm / 18 mm / 20 mm / 24 mm / 25 mm / 27 mm / 28 mm / 30 mm / 32 mm / 38 mm / 40 mm (Hub shaft)
Flange (Mounting of housing)	Tether
Mounting of shaft	Front clamping ring, Rear clamping ring
Protection class shaft input (EN 60529)	IP40 or IP64
Protection class housing (EN 60529)	IP50 (IP65 optional)
Minimum length of mounting shaft clamping ring front	32 mm with $\varnothing$ 15 ... 30, 35 mm with $\varnothing$ >30 ... 42
Minimum length of mounting shaft clamping ring rear	corresponding to total length of encoder
Axial endplay of mounting shaft (hubshaft)	With stator coupling A (flexible): $\pm$ 2 mm With 1x stator coupling (torsionally rigid): $\pm$ 0.5 mm With 2x stator coupling (torsionally rigid): $\pm$ 0.3 mm
Radial runout of mating shaft (hubshaft)	With stator coupling A (flexible): $\pm$ 0.15 mm With 1x stator coupling (torsionally rigid): $\pm$ 0.3 mm With 2x stator coupling (torsionally rigid): $\pm$ 0.2 mm
Max. speed	for $\varnothing$ 15 ... 25 mm at 70 °C and IP64: max. 3600 rpm for $\varnothing$ >25 ... 42 mm bei 70 °C and IP64: max. 1800 rpm for $\varnothing$ 15 ... 42 mm at 70 °C and IP40: max. 6000 rpm for $\varnothing$ 15 ... 42 mm at 100 °C always: max. 1800 rpm
Torque	3 ... 10 Ncm (depending on version)
Moment of inertia	approx. 140 ... 420 gcm <sup>2</sup> (depending on version)
Vibration resistance (DIN EN 60068-2-6)	10 g = 100 m/s <sup>2</sup> (10 ... 2000 Hz)
Shock resistance (DIN EN 60068-2-27)	100 g = 1000 m/s <sup>2</sup> (6 ms)
Operating temperature	-25 °C ... +100 °C
Storage temperature	-25 °C ... +100 °C
Material housing	Aluminum
Weight	approx. 320 ... 580 g (depending on version)
Connection	Cable, radial

**TECHNICAL DATA**  
**electrical**

General design	as per DIN EN 61010-1, protection class III, contamination level 2, overvoltage class II
----------------	--

## Incremental

## Hollow Shaft

### TECHNICAL DATA electrical (continued)

Supply voltage <sup>1</sup>	RS422 + Sense (T): DC 5 V ±10 % RS422 + Alarm (R): ± 10% DC 5 V or DC 10 - 30 V Push-pull (K), Push-pull antivalent (I): DC 10-30 V
Max. current w/o load	60 mA (DC 5 V), 60 mA (DC 10 V), 35 mA (DC 24 V)
Max. pulse frequency	RS422: 300 kHz Push-pull: 200 kHz
Standard output versions <sup>2</sup>	RS422 + Alarm (R): A, B, N, $\bar{A}$ , $\bar{B}$ , $\bar{N}$ , $\overline{Alarm}$ RS422 + Sense (T): A, B, N, $\bar{A}$ , $\bar{B}$ , $\bar{N}$ , Sense Push-pull (K): A, B, N, $\overline{Alarm}$ Push-pull complementary (I): A, B, N, $\bar{A}$ , $\bar{B}$ , $\bar{N}$ , $\overline{Alarm}$
Pulse width error	± max. 25° electrical
Number of pulses	1 ... 10 000
Alarm output	NPN-O.C., max. 5 mA
Pulse shape	Square wave
Pulse duty factor	1:1

<sup>1</sup> Pole protection with supply voltage DC 10 - 30 V

<sup>2</sup> Output description and technical data see chapter "Technical basics"

### SHAFT CONNECTION

Shaft fixing is done through a clamping ring either on the flange or cap side. As a rule, flange side clamping is better for smaller motors as the available shaft stub is correspondingly shorter.

On the other hand, cap side clamping is easier when there is sufficient shaft length available.

### MOUNTING NECESSITIES

In order to compensate for axial and radial shaft eccentricity as well as any angle offset, the encoder flange must not be rigidly mounted. Please mount the flange with a flexible stator coupling (e.g. hubshaft with tether) as torque support

There are two flexible mounting plates:

- A flexible hubshaft with tether (A) for higher levels of play and lower requirements for accuracy.
- A rigid hubshaft with tether (N) for reduced play and rigid connection with reduced swing angle. This is suitable in the case of higher accuracy and dynamics requirements.

### ELECTRICAL CONNECTIONS Cable TPE

Colour (TPE)	Output circuit			
	RS422 + Sense (T)	RS422 + Alarm (R)	push-pull (K)	push-pull complementary (I)
brown	Channel A	Channel A	Channel A	Channel A
green	Channel $\bar{A}$		Channel $\bar{A}$	Channel $\bar{A}$
grey	Channel B	Channel B	Channel B	Channel B
pink	Channel $\bar{B}$	Channel $\bar{B}$		Channel $\bar{B}$
red	Channel N	Channel N	Channel N	Channel N
black	Channel $\bar{N}$	Channel $\bar{N}$		Channel $\bar{N}$
violet (white) <sup>1</sup>	Sense GND	$\overline{Alarm}$	$\overline{Alarm}$	$\overline{Alarm}$
blue	Sense V <sub>CC</sub>	Sense V <sub>CC</sub>		Sense V <sub>CC</sub>
brown/green	DC 5 V	DC 5/10 - 30 V	DC 10 - 30 V	DC 10 - 30 V
white/green	GND	GND	GND	GND
Cable screen <sup>2</sup>	Cable screen <sup>2</sup>	Cable screen <sup>2</sup>	Cable screen <sup>2</sup>	Cable screen <sup>2</sup>

<sup>1</sup> white for version Sense (T)

<sup>2</sup> connected with encoder housing

DIMENSIONED DRAWINGS

With hubshaft with tether "rigid"

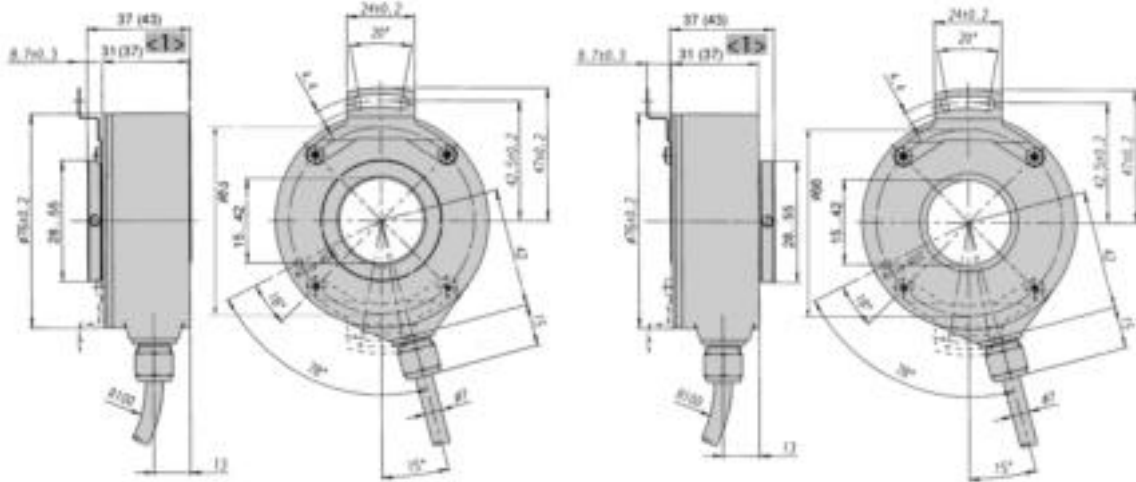

<1> Values in brackets for shaft diameter > 30, diameter of connection shaft 15<sup>98</sup> ... 42<sup>98</sup>

Cable bending radius R for flexible installation ≥ 100 mm  
Cable bending radius R for fixed installation ≥ 40 mm

Dimensions in mm

With hubshaft with tether "flexible"

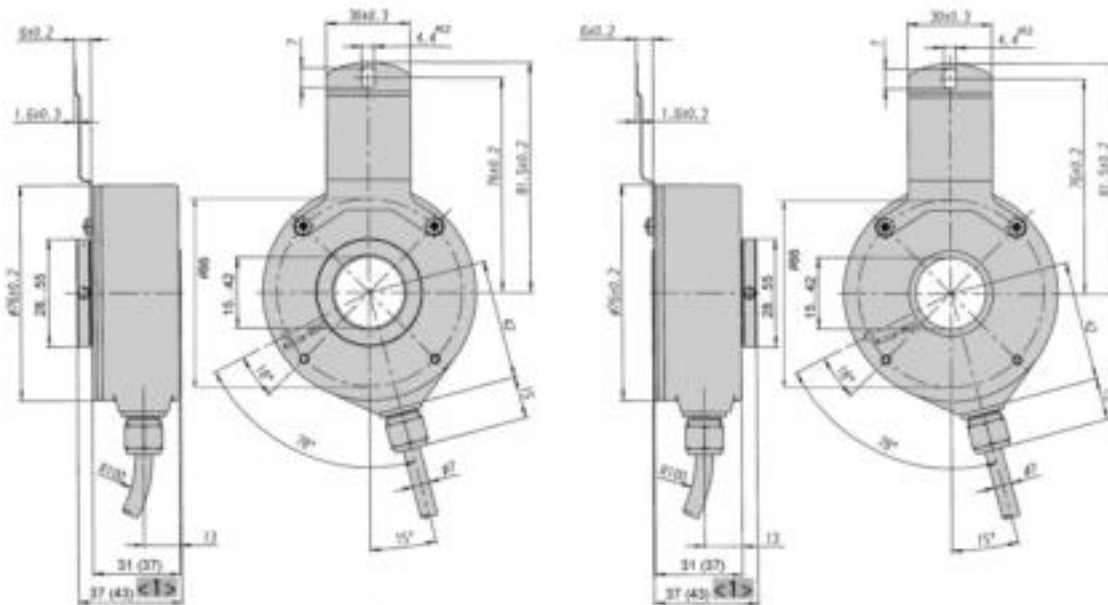

<1> Values in brackets for shaft diameter > 30, diameter of connection shaft 15<sup>98</sup> ... 42<sup>98</sup>

Cable bending radius R for flexible installation ≥ 100 mm  
Cable bending radius R for fixed installation ≥ 40 mm

Dimensions in mm



### ORDERING INFORMATION

Type	Number of pulses	Supply voltage <sup>1,2</sup>	Shaft	Protection	Spring tether	Shaft Ø <sup>3,4,5,6</sup>	Output	Connection
<input type="checkbox"/>	<input type="checkbox"/>	<input type="checkbox"/>	<input type="checkbox"/>	<input type="checkbox"/>	<input type="checkbox"/>	<input type="checkbox"/>	<input type="checkbox"/>	<input type="checkbox"/>
<b>RI76TD</b>	<b>1 ... 10000</b>	<b>A</b> DC 5 V <b>E</b> DC 10 - 30 V	<b>D</b> Clamping shaft with clamping ring front <b>H</b> Clamping shaft with clamping ring rear	<b>1</b> IP40 <b>4</b> IP64	<b>O</b> Without <b>A</b> Flexible <b>N</b> Rigid	<b>15 ... 42</b> 15 ... 42 mm <b>50 ... 99</b> 50 ... 99 Zoll <b>50</b> = 5/8" <b>51</b> = 1 5/8" <b>52</b> = 3/4"	<b>R</b> RS422 +Alarm <b>T</b> RS422 +Sense <b>K</b> Push-pull <b>I</b> Push-pull complementary	<b>F</b> TPE cable, radial

<sup>1</sup> DC 5 V: only with output "T", "R" available

<sup>2</sup> DC 10 - 30 V: only with output "K", "I", "R" available

<sup>3</sup> Available with front clamping ring and IP40: **15, 20, 24, 25, 27, 28, 30, 38, 40, 42, 50** (5/8"), **51** (1 5/8")

<sup>4</sup> Available with front clamping ring and IP64: **15, 16, 18, 20, 24, 25, 27, 28, 30, 32, 38, 40, 42, 50** (5/8"), **51** (1 5/8"), **52** (3/4")

<sup>5</sup> Available with rear clamping ring and IP40: **25, 28, 30, 32, 38, 40, 42**

<sup>6</sup> Available with rear clamping ring and IP64: **20, 25, 30, 32, 38, 40, 42**

Preferably available versions are printed in bold type.

Others: please request delivery time

### ORDERING INFORMATION

#### Selection of cable length

Versions with cable outlet (connection A, B, E or F) are available with various lengths of cable. To order your desired cable length, please add the respective code to the end of your ordering code. Further cable lengths on request.

Code	Cable length
without code	1.5 m
-D0	3 m
-F0	5 m
-K0	10 m
-P0	15 m
-U0	20 m
-V0	25 m

### ACCESSORIES

see chapter "Accessories", starting page 322

Incremental

Hollow Shaft



- Incremental
- 30 - 45 mm hollow shaft
- Rugged mechanical design
- Unbreakable disc
- Integrated diagnostic system
- Wide voltage range DC 5 - 30 V
- Isolated shaft



NUMBER OF PULSES

1024 / 2048 / 2500 / 4096 / 5000 / 10000  
 Other number of pulses on request

GENERAL INFORMATION

The central element of the RI80-E is the latest Hengstler OptoAsic technology, which offers the following key benefits:

- Highest EMC immunity
- Outstanding reliability by reduced number of components and integrated diagnostics system
- Aging compensation by integrated LED light regulation
- Integrated monitoring of pollution, disk damage, LED lifetime, temperature

A robust and generously dimensioned mechanical design ensures long maintenance free operation.

The RI80-E is ideally suited for applications like:

- Geared Elevators
- Asynchronous Motors
- Industrial Machinery

TECHNICAL DATA  
 mechanical

Housing diameter	100 mm
Shaft diameter	30 mm / 45 mm (Through hollow shaft)
Flange (Mounting of housing)	Tether
Mounting of shaft	Keyway, Set screw
Protection class shaft input (EN 60529)	IP50 or IP64
Protection class housing (EN 60529)	IP50 or IP64
Axial endplay of mounting shaft (hubshaft)	± 0.5 mm
Radial runout of mating shaft (hubshaft)	± 0.05 mm
Max. speed	IP50: max. 3600 rpm IP64: max. 1500 rpm
Operating temperature	-25 °C ... +85 °C
Storage temperature	-40 °C ... +70 °C
Material shaft	Aluminum, ceramic coating
Material housing	Aluminum / glass fiber-reinforced plastic
Weight	670 g
Connection	Sub-D connector Cable, radial

## Incremental

## Hollow Shaft

TECHNICAL DATA  
electrical

General design	as per DIN EN 61010-1, protection class III, contamination level 2, overvoltage class II
Supply voltage <sup>1</sup>	DC 5 V ±10 % or DC 5 - 30 V
Max. current w/o load	60 mA (DC 5 V), 60 mA (DC 10 V), 35 mA (DC 24 V)
Max. pulse frequency	RS422: 600 kHz Push-pull: 200 kHz
Standard output versions <sup>2</sup>	RS422 (R): A, B, N, $\bar{A}$ , $\bar{B}$ , $\bar{N}$ , $\overline{\text{Alarm}}$ , Sense Push-pull (K): A, B, N, $\overline{\text{Alarm}}$ Push-pull complementary (I): A, B, N, $\bar{A}$ , $\bar{B}$ , $\bar{N}$ , $\overline{\text{Alarm}}$
Pulse width error	± max. 25° electrical
Number of pulses	1024, 2048, 2500, 4096, 5000, 10 000, (other number of pulses on request)
Alarm output	NPN-O.C., max. 5 mA
Pulse shape	Square wave
Pulse duty factor	1:1

<sup>1</sup> Pole protection with supply voltage DC 5 - 30 V

<sup>2</sup> Output description and technical data see chapter "Technical basics"

ELECTRICAL CONNECTIONS  
Cable TPE

Color	RS422 + Alarm + Sense (R)	Push-pull (K)	Push-pull Complement. (I)
brown	Channel A	Channel A	Channel A
green	Channel $\bar{A}$		Channel $\bar{A}$
gray	Channel B	Channel B	Channel B
pink	Channel $\bar{B}$		Channel $\bar{B}$
red	Channel N	Channel N	Channel N
black	Channel $\bar{N}$		Channel $\bar{N}$
violet	$\overline{\text{Alarm}}$	$\overline{\text{Alarm}}$	$\overline{\text{Alarm}}$
white	Sense GND		Sense GND
blue	Sense $V_{cc}$		Sense $V_{cc}$
brown/green	DC 5 - 30 V	DC 5 - 30 V	DC 5 - 30 V
white/green	GND	GND	GND
screen <sup>1</sup>	screen <sup>1</sup>	screen <sup>1</sup>	screen <sup>1</sup>

<sup>1</sup> connected with encoder housing

Incremental

Hollow Shaft

**ELECTRICAL CONNECTIONS**  
Sub-D connector, 15 pole/ 9 pole

Pin	Signal 15 pole	Signal 9 pole
1	$\bar{B}$	GND
2	B	+Ub
3	$\bar{A}$	A
4	A	B
5	GND	N
6	+Ub	$\bar{A}$
7	n.c.	$\bar{B}$
8	screen	$\bar{N}$
9	$\bar{N}$	
10	N	
11	n.c.	
12	n.c.	
13	n.c.	
14	n.c.	
15	n.c.	

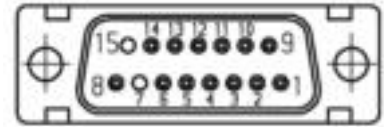

**DIMENSIONED DRAWINGS**

Set screw

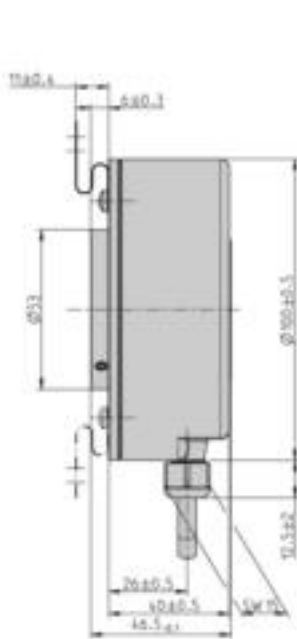

<1> M4 (depth 6)

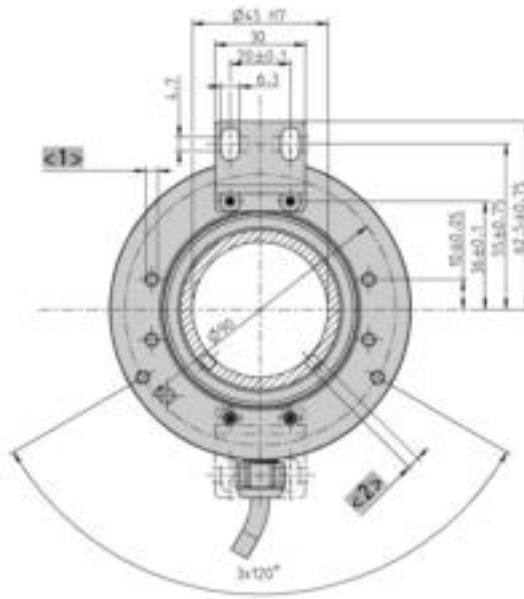

<2> M4 (2 x 90°)



Dimensions in mm

DIMENSIONED DRAWINGS (continued)

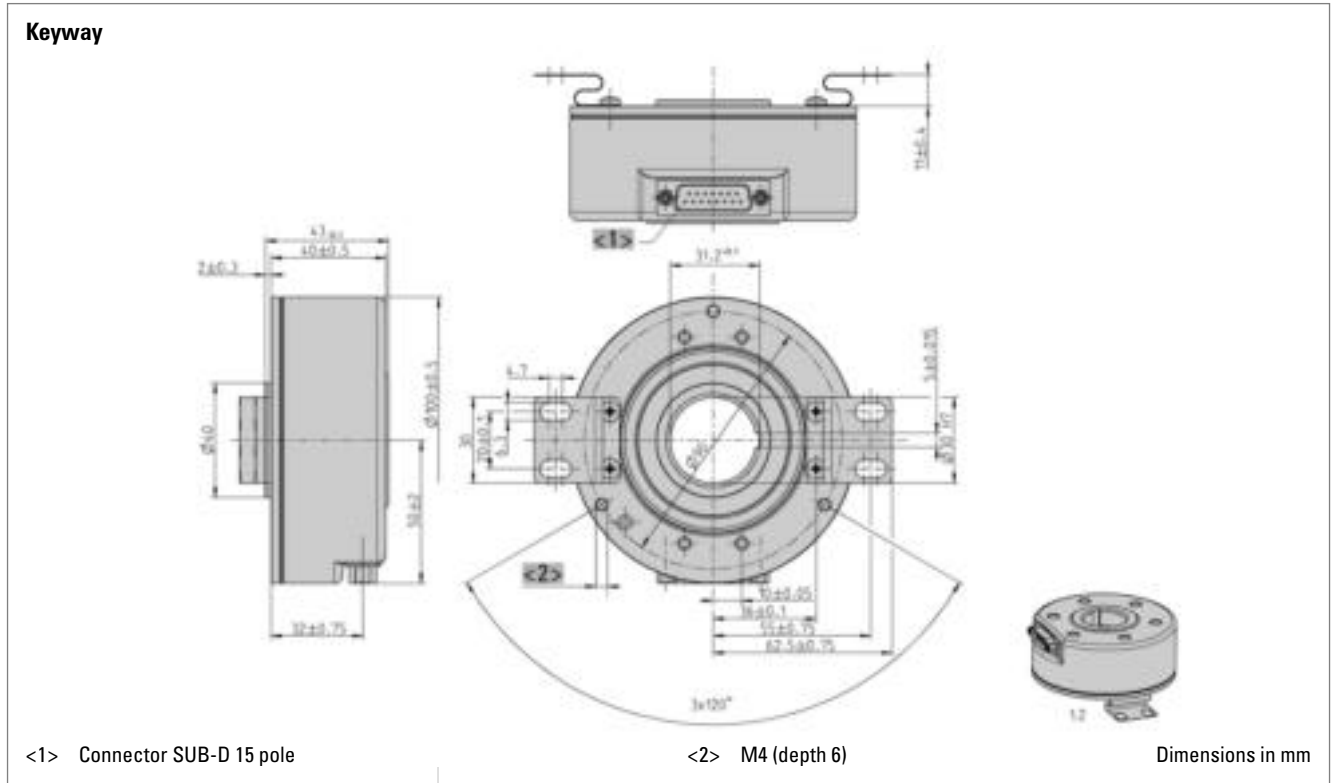

ORDERING INFORMATION

Type	Number of pulses <sup>2</sup>	Supply voltage	Spring tether	Protection	Shaft	Output <sup>1</sup>	Connection
<input type="checkbox"/>	<input type="checkbox"/>	<input type="checkbox"/>	<input type="checkbox"/>	<input type="checkbox"/>	<input type="checkbox"/>	<input type="checkbox"/>	<input type="checkbox"/>
<b>RI80-E</b>	<b>1024</b> <b>2048</b> <b>2500</b> <b>4096</b> <b>10000</b> <b>5000</b>	<b>A</b> DC 5 V <b>B</b> DC 5 - 30 V	<b>O</b> Without tether <b>A</b> Spring tether single <b>B</b> Spring tether double <b>C</b> RI76 compatible (A)	<b>0</b> IP40 <b>1</b> IP50 <b>4</b> IP64	<b>G30</b> Set screw / 30 mm <b>G38</b> Set screw / 38 mm <b>G40</b> Set screw / 40 mm <b>G45</b> Set screw / 45 mm <b>K30</b> Keyway / 30 mm 1" isolated on request	<b>R</b> RS422 +Alarm +Sense <b>K</b> HTL <b>I</b> HTL complementary	<b>F</b> TPE cable, radial <b>E-I</b> M23 connector (Conin) at 1 m TPE cable, cw <b>E-D</b> M23 connector (Conin) at 1 m TPE cable, ccw <b>3</b> Sub-D connector, 9 pole <b>4</b> Sub-D connector, 15 pole

<sup>1</sup> Output code "K" and "I": Driver type DL, see < www.ichaus.de >

<sup>2</sup> Other number of pulses on request

**Incremental****Hollow Shaft****ORDERING INFORMATION****Selection of cable length**

Versions with cable outlet (connection A, B, E or F) are available with various lengths of cable. To order your desired cable length, please add the respective code to the end of your ordering code. Further cable lengths on request.

<b>Code</b>	<b>Cable length</b>
without code	1.5 m
-D0	3 m
-F0	5 m
-K0	10 m
-P0	15 m
-U0	20 m
-V0	25 m

**ACCESSORIES**

see chapter "Accessories", starting page 322

## Standard Industrial Types Absolute



Absolute shaft encoders, also known as shaft-angle encoders, are by no means used only to detect angular positions. They are also suitable for linear movements that can be converted into rotary movements by a toothed belt, drive pinion, or wire winch.

The special feature of absolute shaft encoders is that they assign a unique, digitally encoded signal to each individual measured increment. The method of transducing prevents erroneous readings, whether by a power failure, or by a transient malfunction. After the encoder is switched on again, or power is restored, the position can be read out. It is not necessary to move to a reference position, as it is for shaft encoders of the incremental type.

### Examples of application for absolute encoders

- overhead support robots
- ventilation flaps
- spinning machines
- conveyor belts
- cam controllers
- injection moulding machines
- packaging machinery
- extruders
- folding machines
- printing machines
- high lift storage systems
- stamping machines

## Absolute

## BiSS / SSI



- Overall length: 36 mm
- For equipment engineering and industry
- Up to 17 Bit Resolution Singleturn + 12 Bit Multiturn
- Solid shaft 6 mm (Hollow shaft version: AD 36)
- +100°C operating temperature
- 10,000 rpm (continuous)
- Optical encoder with a true geared multiturn
- BiSS or SSI interface
- Option Sinewave 1 Vpp
- Bandwidth 500 kHz



## APPLICATIONS

The AC 36 is an absolute optical encoder with a true geared multiturn, optical sensing technology and 36 mm diameter. Equipped with a solid-shaft the AC 36 is mechanical compatible with all common inkremental encoders. The compact design allows to replace the adequate incremental encoders directly. As a result the technical facilities of absolute encoders can be used for the first time in equipment engineering and also in medical engineering. The mechanical design consists of two ball bearings supported mechanical shaft assembly. The AC 36 complements the **ACURO® -industry** series with small frame sizes and the same performance as 58 mm versions.

**BiSS-Interface**

Unique within his class the AC 36 provides fully digital position data up to 17 Bit (singleturn) and 12 Bit (multi-turn) over the bidirectional synchronous interface with a variable clock rate up to 10 MHz. This corresponds a singleturn resolution of more than 130 000 mesured steps. Backward compatibility is realized through the SSI interface together with 2048 sine-cosine periods per revolution.

**Integrated diagnostic system**

The AC 36 is based on latest OptoAsic technology with an advanced diagnostic concept. A continous plausibility check controls the internal signal processing for each increment. A code check guarantees that the encoder signal represents bit by bit the mesured rotation. Also the operating temperature of the encoder can be measured, read out and monitored over warn and alarm bits with 8 bit resolution (1°C). Monitoring and controlling of the operating temperature ensures a maximum lifetime of the LED. Eventual failures are indicated early over warn bits.

TECHNICAL DATA  
mechanical

Housing diameter	37.5 mm
Shaft diameter	6 mm (Solid shaft)
Flange (Mounting of housing)	Pilot flange
Protection class shaft input (EN 60529)	IP64
Protection class housing (EN 60529)	IP64
Max. speed	max. 10 000 rpm (continuous), max. 12 000 rpm (short term)
Torque	0.01 Nm
Moment of inertia	ca. $2.5 \times 10^{-6}$ kgm <sup>2</sup>
Vibration resistance (DIN EN 60068-2-6)	100 m/s <sup>2</sup> (10 ... 2000 Hz)



## Absolute

## BiSS / SSI

TECHNICAL DATA  
mechanical (continued)

Shock resistance (DIN EN 60068-2-27)	1000 m/s <sup>2</sup> (6 ms)
Operating temperature	-25 °C ... +100 °C
Storage temperature	-15 °C ... +85 °C
Weight	approx. 80 g (ST) / 130 g (MT)
Connection	Cable, axial or radial

TECHNICAL DATA  
electrical

Supply voltage	-5%/ 10% DC 5 V DC 7-30 V
Max. current w/o load	50 mA (ST), 100 mA (MT)
Resolution singleturn	12 -17 Bit
Resolution multiturn	12 Bit
Output code	Gray, Binary
Drives	Clock and Data / RS422
Incremental signals optional	Sinus-Cosinus 1 Vpp
Number of pulses	2048
3dB limiting frequency	500 kHz
Alarm output	Alarm bit (SSI Option), warning and alarm bit (BiSS)

ELECTRICAL CONNECTIONS  
Cable

Signal	Colour cable
5 / 7-30 V (U <sub>B</sub> )	white
0 V (U <sub>N</sub> )	brown
Clock	yellow
$\overline{\text{Clock}}$	green
Data	pink
$\overline{\text{Data}}$	grey
A	white/green <sup>1</sup>
$\overline{A}$	brown/green <sup>1</sup>
B	red/blue <sup>1</sup>
$\overline{B}$	grey/pink <sup>1</sup>
5 V Sensor	violet <sup>1</sup>
0 V Sensor	black <sup>1</sup>

<sup>1</sup> only with "SC"

### DIMENSIONED DRAWINGS

#### Connection axial

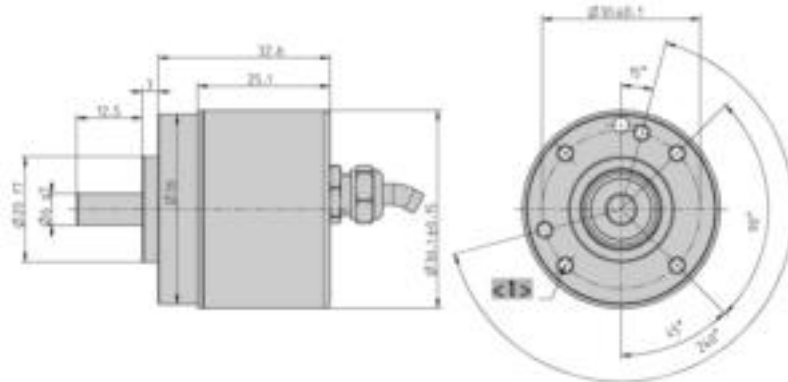

<1> M3 (depth 6)

Dimensions in mm

#### Connection radial

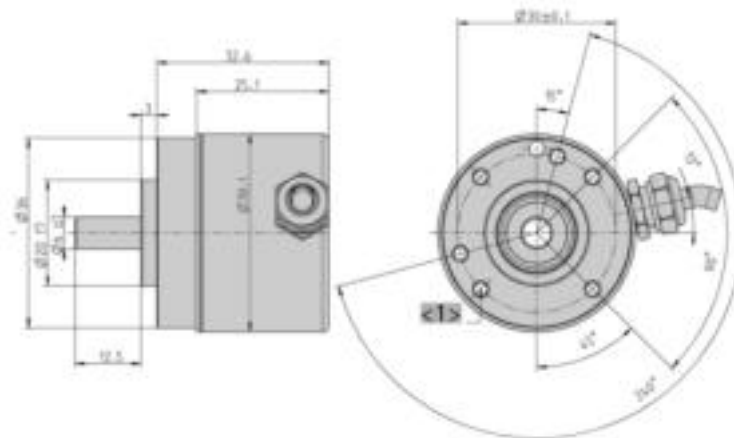

<1> M3 (depth 6)

Dimensions in mm

### ORDERING INFORMATION

Type	Resolution	Supply voltage	Flange, Protection, Shaft	Interface	Connection
<input type="checkbox"/>	<input type="text"/>	<input type="checkbox"/>	<input type="text"/>	<input type="text"/>	<input type="text"/>
<b>AC36</b>	<b>0012</b> 12 Bit ST <b>0013</b> 13 Bit ST <b>0014</b> 14 Bit ST <b>0017</b> 17 Bit ST <b>1213</b> 12 Bit MT + 13 Bit ST <b>1217</b> 12 Bit MT + 17 Bit ST (BiSS)	<b>A</b> DC 5 V <b>E</b> DC 7 - 30 V	<b>R.41</b> Pilot, IP64, 6 mm	<b>BI</b> BiSS <b>SB</b> SSI binary <b>SG</b> SSI Gray <b>SC</b> SSI Gray (+SinCos 1Vpp)	<b>A</b> Cable, axial <b>B</b> Cable, radial

**Absolute****BiSS / SSI****ORDERING INFORMATION**  
Selection of cable length

Versions with cable outlet (connection A, B, E or F) are available with various lengths of cable. To order your desired cable length, please add the respective code to the end of your ordering code. Further cable lengths on request.

Code	Cable length
without code	1.5 m
-D0	3 m
-F0	5 m
-K0	10 m
-P0	15 m
-U0	20 m
-V0	25 m

**ACCESSORIES**

see chapter "Accessories", starting page 322

# Absolute Shaft Encoders ACURO industry

## Overview Functions and Versions AC 58

	SSI	BiSS	Parallel ST	Parallel MT	SSI para.	Profibus	DeviceNet	Interbus	CAN	CANopen	SUCOnet
<b>Electrical</b>											
Supply DC 5 V	•	•	(Option)	(Option)							
Supply DC 10-30 V	•	•	•	•	•	•	•	•	•	•	•
Preset key with LED (not IP67)	•	•	only LED	•	•						
<b>Diagnostics</b>											
- LED indication	•	•		•	•	•	•	•	•	•	
- Warning		•				•					
- Alarm bit	(Option)	•				•	•	•	•	•	
- Alarm output	(Option)	(Option)	•	•							
- Temperature measurement	(Option)	•									
Connection for "tico"						•	•		•	•	
Parameterization (PC, with Acuro Soft)	•	•									
Parameterization (Bus)						•	•	•		•	•
<b>Inputs</b>											
- Latch			•	•							
- Direction	•	•	•	•	•						
- 2 lines for present input					•						
- Tristate			•	•							
<b>Special Functions</b>											
- Speed						•			•	•	
- Acceleration						•			•	•	
- On time						•				•	
- Round axis										•	
- Limit values					•					•	
Optional 1 Vpp	•	•									
<b>Connections</b>											
Bus cover, 3 cable screw						•		•	•	•	
Bus cover, 2 cable screw+M12 for "tico"						•	•		•	•	
Bus cover, 2 cable screw							•				
Bus cover, 2 Conin 9-pole								•	•	•	
Bus cover, 2 Conin 12-pole						•					
Bus cover, 3 M12 4-pole						•					
Bus cover, 1 M12 5-pole							•				
Cable axial / radial	•	•	•	•	•			•	•	•	•
Cable ax /rad 0.1 m+37-pole Sub-D				•							
Conin 12-pole ax/rad CW/CCW	•	•			•	•			•	•	
Conin 17-pole ax/rad CW/CCW			•								
M12 8-pole ax/rad	•	•									
<b>Mechanical</b>											
Synchro fl., shaft 6x10 mm, IP64 or IP67	•	•	•	•	•	•	•	•	•	•	•
Clamping fl., shaft 10x19.5 mm, IP64 or IP67	•	•	•	•	•	•	•	•	•	•	•
Clamping fl., shaft 9.52x19.5 mm, IP64 or IP67	•	•	•	•	•	•	•	•	•	•	•
Hubshaft with tether 10 mm, IP64	•	•	•	•	•	•	•	•	•	•	•
Hubshaft with tether 12 mm, IP64	•	•	•	•	•	•	•	•	•	•	•
Hubshaft with tether 12,7 mm, IP64	•	•	•	•	•	•	•	•	•	•	•
Square flange, 63.5 mm, shaft 9.52x19.5 mm, IP64 or IP67	•	•	•	•	•	•	•	•	•	•	•
Square flange, 63.5 mm, shaft 10 x 19.5 mm, IP64 or IP67	•	•	•	•	•	•	•	•	•	•	•

## Absolute

## BiSS / SSI



Clamping flange

- Compact design: 50 mm length for single or multiturn
- Aids for start up and operation: diagnostic LED, preset key with optical response, status information
- Use of sine/ cosine signals for fast control task possible
- Control input: Direction
- Resolution up to 29 Bit

**TECHNICAL DATA**  
**mechanical**

Housing diameter	58 mm
Shaft diameter	6 mm / 10 mm (Solid shaft) 10 mm / 12 mm (Hub shaft)
Flange (Mounting of housing)	Synchro flange, Clamping flange, Tether, Square flange
Protection class shaft input (EN 60529)	IP64 or IP67
Protection class housing (EN 60529)	IP64 or IP67
Shaft load axial / radial	40 N / 60 N
Axial endplay of mounting shaft (hubshaft)	± 1.5 mm
Radial runout of mating shaft (hubshaft)	± 0.2 mm
Max. speed	max. 10 000 rpm (continuous), max. 12 000 rpm (short term)
Torque	0.01 Ncm
Moment of inertia	ca. 3.8 x 10 <sup>-6</sup> kgm <sup>2</sup>
Vibration resistance (DIN EN 60068-2-6)	100 m/s <sup>2</sup> (10 ... 2000 Hz)
Shock resistance (DIN EN 60068-2-27)	1000 m/s <sup>2</sup> (6 ms)
Operating temperature	-40 °C ... +100 °C
Storage temperature <sup>1</sup>	-25 °C ... +85 °C
Weight	approx. 260 g (ST) / 310 g (MT)
Connection	Cable, axial or radial M23 connector (Conin), 12 pole, axial or radial M12-connector, 8 pole, axial or radial

<sup>1</sup> due to packaging

**TECHNICAL DATA**  
**electrical**

Supply voltage	± 10% DC 5 V or DC 10 - 30 V
Max. current w/o load	50 mA (ST), 100 mA (MT)
Resolution singleturn	10 - 17 Bit Gray Excess: 360, 720 increments
Resolution multiturn	12 Bit
Output code	Binary, Gray
Drives	Clock and Data / RS422
Linearity	± ½ LSB (± 1 LSB for resolution > 13 Bit)

## Absolute

## BiSS / SSI

### TECHNICAL DATA electrical (continued)

Incremental signals optional	Sinus-Cosinus 1 Vpp
Number of pulses	2048
3dB limiting frequency	500 kHz
Absolute accuracy	±35"
Repeatability	±7"
Parametrization	Code type, Direction, Warning, Alarm
Control inputs	$\overline{\text{Direction}}$
Reset key	Disable via parameterization
Alarm output	Alarm bit (SSI Option), warning and alarm bit (BiSS)
Status LED	Green = ok, red = alarm

### RECOMMENDED DATA TRANSFER RATE bei SSI

The max. data transfer rate depends on the cable length. For Clock /  $\overline{\text{Clock}}$  and Data /  $\overline{\text{Data}}$  please use twisted pairs. Use shielded cable.

Cable length	Frequency
< 50 m	< 400 kHz
< 100 m	< 300 kHz
< 200 m	< 200 kHz
< 400 m	< 100 kHz

### DATA FORMAT Singleturn

Resolution	Data Bits											
	T1 ... T9	T10	T11	T12	T13	T14	T15	T16	T17	T18	T19	
9 Bit <sup>1</sup>	S8 ... S0	0	0	0	0	0	W <sup>2</sup>					
10 Bit <sup>1</sup>	S9 ... S1	S0	0	0	0	0	W <sup>2</sup>					
11 Bit <sup>1</sup>	S10 ... S2	S1	S0	0	0	0	W <sup>2</sup>					
12 Bit <sup>1</sup>	S11 ... S3	S2	S1	S0	0	0	W <sup>2</sup>					
13 Bit <sup>1</sup>	S12 ... S4	S3	S2	S1	S0	0	W <sup>2</sup>					
14 Bit <sup>1</sup>	S13 ... S5	S4	S3	S2	S1	S0	0	W <sup>2</sup>				
15 Bit <sup>1</sup>	S14 ... S6	S5	S4	S3	S2	S1	S0	0	W <sup>2</sup>			
16 Bit <sup>1</sup>	S15 ... S7	S6	S5	S4	S3	S2	S1	S0	0	W <sup>2</sup>		
17 Bit <sup>1</sup>	S16 ... S8	S7	S6	S5	S4	S3	S2	S1	S0	0	W <sup>2</sup>	

Examples for data format 9 Bit and 13 Bit with the optional bits alarm und parity

Resolution	Data Bits											
	T1 ... T9	T10	T11	T12	T13	T14	T15	T16	T17	T18	T19	
9 Bit + P <sup>3</sup>	S8 ... S0	0	0	0	P	0	W <sup>2</sup>					
9 Bit + A <sup>4</sup>	S8 ... S0	0	0	0	A	0	W <sup>2</sup>					
9 Bit + P <sup>3</sup> + A <sup>4</sup>	S8 ... S0	0	0	0	A	P	0	W <sup>2</sup>				
9 Bit + P <sup>3</sup>	S12 ... S4	S3	S2	S1	S0	P	0	W <sup>2</sup>				
9 Bit + A <sup>4</sup>	S12 ... S4	S3	S2	S1	S0	A	0	W <sup>2</sup>				
9 Bit + P <sup>3</sup> + A <sup>4</sup>	S12 ... S4	S3	S2	S1	S0	A	P	0	W <sup>2</sup>			

Absolute

BiSS / SSI

DATA FORMAT Multiturn

Resolution	Data bits									
	T1 ... T12	T13 ... T21	T22	T23	T24	T25				
24 Bit <sup>1</sup>	M11 ... M0	S11 ... S2	S1	S0	0	W <sup>2</sup>				
25 Bit <sup>1</sup>	M11 ... M0	S12 ... S3	S2	S1	S0	0	W <sup>2</sup>			
26 Bit <sup>1</sup>	M11 ... M0	S13 ... S4	S3	S2	S1	S0	0	W <sup>2</sup>		
Example for data format 24 Bit with the optional bits alarm und parity										
24 Bit + P <sup>3</sup>	M11 ... M0	S11 ... S2	S1	S0	P	0	W <sup>2</sup>			
24 Bit + A <sup>4</sup>	M11 ... M0	S11 ... S2	S1	S0	A	0	W <sup>2</sup>			
24 Bit + P <sup>3</sup> + A <sup>4</sup>	M11 ... M0	S11 ... S2	S1	S0	A	P	0	W <sup>2</sup>		

S0 ... S16 Data bits for resolution per revolution

M0 ... M11 Data bits for number of revolutions (only for multiturn)

<sup>1</sup> Options (Parity bit, alarm and parity bit, zero bit) on request

<sup>2</sup>W: from this data bit on the data iteration for multiplex starts

<sup>3</sup>Parity bit: Even Parity (The parity bit expands the data bits to an even number of 1-bits).  
(Option)

<sup>4</sup>Alarm bit: is set to "1" when over temperature, under temperature, disc breakage and defect LED

SYNCHRONOUS-SERIAL TRANSFER (SSI)

Synchronous readout of the encoder data is according to the clock rate given by the SSI-counterpart.

The number of clock rates is determined by the type of encoder (singleturn resp. multiturn) and the configuration of the special Bits as defined.

For multiple transactions (the stored value is readout several times successively) a fixed clock rate per transaction must be kept (for singleturn 13 resp. 14 clocks, for multiturn 25 resp. 26 clocks).

- In the rest position, when the last clock brush has passed by more than 30µs, the data output is logically at "1".
- With the first descending clock edge the encoder data and the special bits are

loaded in the shift register of the encoder interface.

- With each ascending clock edge the data bits are serially readout, beginning with the MSB.
- At the end of the data transfer the data output is set to logically "0" for approx. 20µs. If within these 20µs a further clock brush reaches the encoder interface, the already transferred data is readout once again. This multiple transfer of the same data makes it possible to recognize transfer errors.
- After the 20µs the data output goes to its rest position, logically "1". Subsequently new encoder data can be readout.

## Absolute

## BiSS / SSI

## ELECTRICAL CONNECTIONS

M23 connector (Conin), 12 pole / cable  
Interface BI, SB, SG

Cable	M23 (Conin)	Signal
brown <sup>3</sup>	1	0 V (supply voltage)
pink	2	Data
yellow	3	Clock
	4	N.C.
blue	5	$\overline{\text{Direction}}$ <sup>1</sup>
red	6	N.C.
violet	7	N.C.
white <sup>3</sup>	8	DC 5/ 10 - 30 V
	9	N.C.
grey	10	$\overline{\text{Data}}$
green	11	$\overline{\text{Clock}}$
black	12	0 V-signal output <sup>2</sup>

<sup>1</sup>  $\overline{\text{Direction}}$ : +U<sub>B</sub> or unconnected = ascending code values with rotation cw  
0 V = descending code values with rotation cw

<sup>2</sup> Connected with 0 V in the encoder.  
Use this output to lay Direction on logical "0" if required.

<sup>3</sup> use only thin wires ( $\varnothing = 0.14$  mm)

## ELECTRICAL CONNECTIONS

M23 connector (Conin), 12 pole / cable  
Interface SC, BC

Cable	M23 (Conin)	Signal
brown <sup>2</sup>	1	0 V (supply voltage)
pink	2	Data
yellow	3	Clock
white/green	4	A+
blue	5	$\overline{\text{Direction}}$ <sup>1</sup>
red/blue	6	B+
brown/green	7	A-
white <sup>2</sup>	8	DC 5/10 - 30 V
grey/pink	9	B-
grey	10	$\overline{\text{Data}}$
green	11	$\overline{\text{Clock}}$
black	12	Sense

<sup>1</sup>  $\overline{\text{Direction}}$ : +U<sub>B</sub> or unconnected = ascending code values with rotation cw  
0 V = descending code values with rotation cw

<sup>2</sup> use only thin wires ( $\varnothing = 0.14$  mm)



Absolute

BiSS / SSI

**ELECTRICAL CONNECTIONS**  
**M12 connector, 8 pole**

Colour	Pin	Signal
white	1	DC 10 - 30 V
brown	2	0 V
	3	N.C.
green	4	Clock
pink	5	Data
yellow	6	Clock
blue	7	Direction <sup>1</sup>
grey	8	Data



View on connector

<sup>1</sup> Direction: + U<sub>B</sub> or unconnected = ascending code values with rotation cw  
 0 V = descending code values with rotation cw

**CONNECTION**



M12, View on connector

**DIMENSIONED DRAWINGS**

see chapter "Dimensioned drawings AC 58", starting page 185

### ORDERING INFORMATION

Type	Resolution <sup>1,2</sup>	Supply voltage <sup>3</sup>	Flange, Protection, Shaft <sup>4,8</sup>	Interface <sup>5,6</sup>	Connection <sup>7</sup>
<input type="checkbox"/>	<input type="text"/>	<input type="checkbox"/>	<input type="checkbox"/>	<input type="checkbox"/>	<input type="checkbox"/>
<b>AC58</b>	<b>0010</b> 10 Bit ST <b>0012</b> 12 Bit ST <b>0013</b> 13 Bit ST <b>0014</b> 14 Bit ST <b>0017</b> 17 Bit ST <b>0360</b> 360 increments ST <b>0720</b> 720 increments ST <b>1212</b> 12 Bit MT + 12 Bit ST <b>1213</b> 12 Bit MT + 13 Bit ST <b>1214</b> 12 Bit MT + 14 Bit ST (BiSS) <b>1217</b> 12 Bit MT + 17 Bit ST (BiSS) higher resolution on request	<b>A</b> DC 5 V <b>E</b> DC 10 - 30 V	<b>S.41</b> <b>Synchro, IP64, 6 mm</b> <b>S.71</b> <b>Synchro, IP67, 6 mm</b> <b>K.42</b> <b>Clamping, IP64, 10 mm</b> <b>K.46</b> Clamping, IP64, 9.52 mm <b>K.72</b> <b>Clamping, IP67, 10 mm</b> <b>K.76</b> Clamping, IP67, 9.52 mm <b>F.46</b> Spring tether, IP64, hubshaft 9.52 mm, mounting with clamping ring front <b>F.42</b> <b>Spring tether, IP64, hubshaft 10 mm, mounting with clamping ring front</b> <b>F.47</b> <b>Spring tether, IP64, hubshaft 12 mm, mounting with clamping ring front</b> <b>Q.46</b> Square, IP64, 9.52 mm <b>Q.42</b> Square, IP64, 10 mm <b>Q.76</b> Square, IP67, 9.52 mm <b>Q.72</b> Square, IP67, 10 mm	<b>BI</b> BiSS <b>BC</b> BiSS (+SinCos 1Vpp) <b>SB</b> SSI binary <b>SG</b> SSI Gray <b>SC</b> SSI Gray (+SinCos 1Vpp)	<b>A</b> Cable, axial <b>B</b> Cable, radial <b>C</b> M23 connector (Conin), 12 pole, axial, cw <b>D</b> M23 connector (Conin), 12 pole, radial, cw <b>G</b> M23 connector (Conin), 12 pole, axial, ccw <b>H</b> M23 connector (Conin), 12 pole, radial, ccw <b>7</b> M12 connector, 8 pole, axial <b>8</b> M12 connector, 8 pole, radial

<sup>1</sup> Resolution 360 increments ST with Offset 76 (value range 76...435)

<sup>2</sup> Resolution 720 increments ST with Offset 152 (value range 152...871)

<sup>3</sup> Max. cable length for DC 5 V: 10 m

<sup>4</sup> Protection class IP67 not available in combination with preset key and LED display

<sup>5</sup> Interface BiSS (+SinCos 1Vpp): not with connection "7" and "8" (M12)

<sup>6</sup> Interface SSI Gray (+SinCos 1Vpp): not with connection "7" and "8" (M12)

<sup>7</sup> Connection code "7" and "8" (M12) with square flange only for IP64 and 10x19,5 mm shaft

<sup>8</sup> IP67 on cover with connector only if IP67 mating connector mounted properly.

**Preferably available versions are printed in bold type.**

### ORDERING INFORMATION

#### Selection of cable length

Versions with cable outlet (connection A, B, E or F) are available with various lengths of cable. To order your desired cable length, please add the respective code to the end of your ordering code. Further cable lengths on request.

Code	Cable length
without code	1.5 m
-D0	3 m
-F0	5 m
-K0	10 m
-P0	15 m
-U0	20 m
-V0	25 m

### ACCESSORIES

see chapter "Accessories", starting page 322

## Absolute

## Parallel



Synchro flange

- Compact design
- Aids for start up and operation: diagnostic LED, preset key with optical response (only with MT), status information
- Output Tristate short circuit-proof
- Gray or Binary code
- Encoder monitoring



### TECHNICAL DATA mechanical

Housing diameter	58 mm
Shaft diameter	6 mm / 10 mm (Solid shaft) 10 mm / 12 mm (Hub shaft)
Flange (Mounting of housing)	Synchro flange, Clamping flange, Tether, Square flange
Protection class shaft input (EN 60529)	IP64 or IP67
Protection class housing (EN 60529)	IP64 or IP67
Shaft load axial / radial	40 N / 60 N
Axial endplay of mounting shaft (hubshaft)	± 1.5 mm
Radial runout of mating shaft (hubshaft)	± 0.2 mm
Max. speed	max. 10 000 rpm (continuous), max. 12 000 rpm (short term)
Torque	0.01 Ncm
Moment of inertia	ca. $3.8 \times 10^{-6}$ kgm <sup>2</sup>
Vibration resistance (DIN EN 60068-2-6)	100 m/s <sup>2</sup> (10 ... 2000 Hz)
Shock resistance (DIN EN 60068-2-27)	1000 m/s <sup>2</sup> (6 ms)
Operating temperature	-40 °C ... +100 °C
Storage temperature	-40 °C ... +85 °C
Weight	approx. 350 g (ST) / 400 g (MT)
Connection <sup>2</sup>	Cable, axial or radial M23 connector (Conin), 17 pole, axial or radial Sub-D connector, 37 pole

### TECHNICAL DATA electrical

Supply voltage	DC 10-30 V On request: DC 5 V
Max. current w/o load	200 mA (ST), 300 mA (MT)
Resolution singleturn	10 - 14 Bit Gray Excess: 360, 720 increments
Resolution multiturn	12 Bit
Output code	Binary, Gray, Gray Excess
Linearity	± ½ LSB
Output current	30 mA per Bit, short-circuit-proof
Control inputs	<u>L</u> atch, <u>D</u> irection, <u>T</u> ristate with ST, Tristate with MT

## Absolute

## Parallel

### TECHNICAL DATA electrical (continued)

Alarm output	NPN-O.C., max. 5 mA
Status LED	Green = ok, red = alarm

### Data output level

Supply voltage $U_B$	DC 5 V - 5 % +10 % <sup>1</sup>	DC 10 - 30 V
Output level High	$\geq 3.5$ V (30 mA) $\geq 3.9$ V (10 mA)	$\geq U_B - 2.2$ V (30 mA) $\geq U_B - 1.8$ V (10 mA)
Output level Low	$\leq 1.6$ V (30 mA) $\leq 1.2$ V (10 mA)	$\leq 1.6$ V (30 mA) $\leq 1.2$ V (10 mA)
Rise time (1.5 m Cable)	$\leq 0.1$ $\mu$ s	$\leq 0.2$ $\mu$ s
Drop time (1.5 m Cable)	$\leq 0.05$ $\mu$ s	$\leq 0.1$ $\mu$ s

<sup>1</sup> on request

### Control inputs

Input	Level logical (physical)	Function
$\overline{\text{Direction}}$	1 (+ $U_B$ or open) 0 (0 V)	ascending code values when turning clockwise (cw) descending code values when turning clockwise (cw)
$\overline{\text{Latch}}$	1 (+ $U_B$ or open) 0 (0 V)	encoder data continuously changing at output encoder data stored and constant at output
$\overline{\text{Tristate}}$ (with singleturn)	1 (+ $U_B$ or open) 0 (0 V)	outputs active outputs at high impedance (Tristate mode)
Tristate (with multiturn)	1 (+ $U_B$ ) 0 (0 V or open)	outputs at high impedance (Tristate mode) outputs active

Typical actuating delay time 10  $\mu$ s with push-pull selection; when selected via O.C., an external pull-down resistor (1 K $\Omega$ ) is required

## Absolute

## Parallel

## ELECTRICAL CONNECTIONS

Singleturn, cable

Colour (PVC)	9 Bit / 360 incr.	10 Bit / 720 incr.	12 Bit	13 Bit	14 Bit
grey/pink	N.C.	N.C.	N.C.	N.C.	S0 (LSB)
brown/yellow	N.C.	N.C.	N.C.	S0 (LSB)	S1
brown/grey	N.C.	N.C.	S0 (LSB)	S1	S2
red/blue	N.C.	N.C.	S1	S2	S3
violet	N.C.	S0 (LSB)	S2	S3	S4
white/brown	S0 (LSB)	S1	S3	S4	S5
white/green	S1	S2	S4	S5	S6
white/yellow	S2	S3	S5	S6	S7
white/grey	S3	S4	S6	S7	S8
white/pink	S4	S5	S7	S8	S9
white/blue	S5	S6	S8	S9	S10
white/red	S6	S7	S9	S10	S11
white/black	S7	S8	S10	S11	S12
brown/green	S8 (MSB)	S9 (MSB)	S11 (MSB)	S12 (MSB)	S13 (MSB)
yellow	Tristate S0...S8	Tristate S0...S9	Tristate S0...S11	Tristate S0...S12	Tristate S0...S13
pink	Latch	Latch	Latch	Latch	Latch
green	Direction	Direction	Direction	Direction	Direction
black	0 V	0 V	0 V	0 V	0 V
red	DC 5 V/ 10-30 V	DC 5 V/ 10-30 V	DC 5 V/ 10-30 V	DC 5 V/ 10-30 V	DC 5 V/ 10-30 V
brown	Alarm	Alarm	Alarm	Alarm	Alarm

## ELECTRICAL CONNECTIONS

Singleturn, M23 connector (Conin), 17 pole

Pin	9 Bit / 360 incr.	10 Bit / 720 incr.	12 Bit	13 Bit	14 Bit
1	S0 (LSB)	S0 (LSB)	S0 (LSB)	S12 (MSB)	S13 (MSB)
2	S1	S1	S1	S11	S12
3	S2	S2	S2	S10	S11
4	S3	S3	S3	S9	S10
5	S4	S4	S4	S8	S9
6	S5	S5	S5	S7	S8
7	S6	S6	S6	S6	S7
8	S7	S7	S7	S5	S6
9	S8 (MSB)	S8	S8	S4	S5
10	N.C.	S9 (MSB)	S9	S3	S4
11	N.C.	N.C.	S10	S2	S3
12	Tristate S0...S8	Tristate S0...S9	S11 (MSB)	S1	S2
13	Latch	Latch	Latch	S0 (LSB)	S1
14	Direction	Direction	Direction	Direction	S0 (LSB)
15	0 V	0 V	0 V	0 V	0 V
16	DC 5 V/ 10-30 V	DC 5 V/ 10-30 V	DC 5 V/ 10-30 V	DC 5 V/ 10-30 V	DC 5 V/ 10-30 V
17	Alarm	Alarm	Alarm	Latch/Alarm	Latch/Alarm

## Absolute

## Parallel

### ELECTRICAL CONNECTIONS

Multiturn, cable

Cable (TPE)	10 cm cable with Sub-D connector, 37 pole		Cable (TPE)	10 cm cable with Sub-D connector, 37 pole	
Colour	Pin	Connection	Colour	Pin	Connection
brown	2	S0	white/blue	14	M4 <sup>1</sup>
green	21	S1	brown/blue	33	M5 <sup>1</sup>
yellow	3	S2	white/red	15	M6 <sup>1</sup>
grey	22	S3	brown/red	34	M7 <sup>1</sup>
pink	4	S4	white/black	16	M8 <sup>2</sup>
violet	23	S5	brown/black	35	M9 <sup>2</sup>
grey/pink	5	S6	grey/green	17	M10 <sup>2</sup>
red/blue	24	S7	yellow/grey	36	M11 <sup>2</sup>
white/green	6	S8	pink/green	18	Alarm
brown/green	25	S9	yellow/pink	10	Direction
white/yellow	7	S10	green/blue	30	Latch
yellow/brown	26	S11	yellow/blue	12	Tristate
white/grey	8	M0	red (0.5mm <sup>2</sup> )	13	DC 10-30 V
grey/brown	27	M1	white (0.5mm <sup>2</sup> )	31	DC 10-30 V
white/pink	9	M2	blue (0.5mm <sup>2</sup> )	1	0 V
pink/brown	28	M3	black (0.5mm <sup>2</sup> )	20	0 V

<sup>1</sup> N. C. with resolution 16 Bit (4 Bit MT)

<sup>2</sup> N. C. with resolution 16 Bit or 20 Bit (4 or 8 Bit MT)

### DIMENSIONED DRAWINGS

see chapter "Dimensioned drawings AC 58", starting page 185

## ORDERING INFORMATION

Type	Resolution <sup>1,2</sup>	Supply voltage	Flange, Protection, Shaft <sup>3,7</sup>	Interface	Connection <sup>4,5,6</sup>
<input type="checkbox"/>	<input type="text"/>	<input type="checkbox"/>	<input type="text"/>	<input type="checkbox"/>	<input type="text"/>
<b>AC58</b>	<b>0010</b> 10 Bit ST <b>0012</b> 12 Bit ST <b>0013</b> 13 Bit ST <b>0014</b> 14 Bit ST <b>0360</b> 360 increments ST <b>0720</b> 720 increments ST <b>0412</b> 4 Bit MT + 12 Bit ST <b>0812</b> 8 Bit MT + 12 Bit ST <b>1212</b> 12 Bit MT + 12 Bit ST	<b>E</b> DC 10 - 30 V	<b>S.41</b> <b>Synchro, IP64, 6 mm</b> <b>S.71</b> <b>Synchro, IP67, 6 mm</b> <b>K.42</b> <b>Clamping, IP64, 10 mm</b> <b>K.46</b> Clamping, IP64, 9.52 mm <b>K.72</b> <b>Clamping, IP67, 10 mm</b> <b>K.76</b> Clamping, IP67, 9.52 mm <b>F.46</b> Spring tether, IP64, hubs-haft 9.52 mm, mounting with clamping ring front <b>F.42</b> <b>Spring tether, IP64, hubs-haft 10 mm, mounting with clamping ring front</b> <b>F.47</b> <b>Spring tether, IP64, hubs-haft 12 mm, mounting with clamping ring front</b> <b>Q.46</b> Square, IP64, 9.52 mm <b>Q.42</b> Square, IP64, 10 mm <b>Q.76</b> Square, IP67, 9.52 mm <b>Q.72</b> Square, IP67, 10 mm	<b>PB</b> Parallel binary <b>PG</b> Parallel Gray	<b>A</b> Cable, axial <b>B</b> Cable, radial <b>U</b> M23 connector (Conin), 17 pole, axial, ccw <b>V</b> M23 connector (Conin), 17 pole, radial, ccw <b>W</b> M23 connector (Conin), 17 pole, axial, cw <b>Y</b> M23 connector (Conin), 17 pole, radial, cw <b>A-A1-F</b> 0,1 m cable with Sub-D connector, 37 pole, axial <b>B-B1-F</b> 0,1 m cable with Sub-D connector, 37 pole, radial

<sup>1</sup> Resolution 360 increments ST with Offset 76 (value range 76...435)

<sup>2</sup> Resolution 720 increments ST with Offset 152 (value range 152...871)

<sup>3</sup> Protection class IP67 not available in combination with preset key and LED display

<sup>4</sup> Connection code "A", "B" (cable): ST and MT

<sup>5</sup> Connection code "U", "V", "W", "Y" (M23 connector): only ST

<sup>6</sup> Connection code "A-A1-F" and "B-B1-F" (Sub-D connector): only MT

<sup>7</sup> IP67 on cover with connector only if IP67 mating connector mounted properly.

Preferably available versions are printed in bold type.

## ORDERING INFORMATION

## Selection of cable length

Versions with cable outlet (connection A, B, E or F) are available with various lengths of cable. To order your desired cable length, please add the respective code to the end of your ordering code. Further cable lengths on request.

Code	Cable length
without code	1.5 m
-D0	3 m
-F0	5 m
-K0	10 m
-P0	15 m
-U0	20 m
-V0	25 m

## ACCESSORIES

see chapter "Accessories", starting page 322

## Absolute

## Profibus

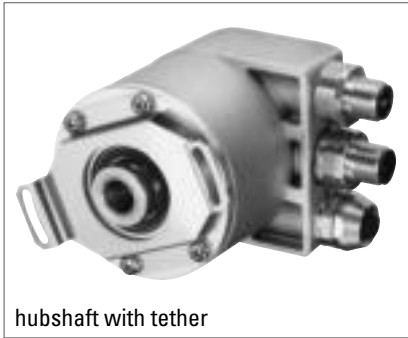

hubshaft with tether

- Diagnostic LED
- Cable or M12 connector
- Output of speed, acceleration
- Programmable: Resolution, Preset, Direction, Operation time
- Option: Display "tico"
- Address via interface parameterizable (optional)



### TECHNICAL DATA mechanical

Housing diameter	58 mm
Shaft diameter	6 mm / 10 mm (Solid shaft) 10 mm / 12 mm (Hub shaft)
Flange (Mounting of housing)	Synchro flange, Clamping flange, Tether, Square flange
Protection class shaft input (EN 60529)	IP64 or IP67
Protection class housing (EN 60529)	IP67
Shaft load axial / radial	40 N / 60 N
Axial endplay of mounting shaft (hubshaft)	± 1.5 mm
Radial runout of mating shaft (hubshaft)	± 0.2 mm
Max. speed	max. 10 000 rpm (continuous), max. 12 000 rpm (short term)
Torque	0.5 Ncm
Moment of inertia	ca. $3.8 \times 10^{-6}$ kgm <sup>2</sup>
Vibration resistance (DIN EN 60068-2-6)	100 m/s <sup>2</sup> (10 ... 500 Hz)
Shock resistance (DIN EN 60068-2-27)	1000 m/s <sup>2</sup> (6 ms)
Operating temperature	-40 °C ... +85 °C
Storage temperature	-40 °C ... +85 °C
Material shaft	Stainless Steel
Material housing	Aluminum
Weight	approx. 350 g (ST) / 400 g (MT)
Connection	Bus cover with 3 sealed cable exits Bus cover with 2x M23 connectors (Conin), 12 pole Bus cover with 3x M12 connector Bus cover with 2 sealed cable exits + 1 x M12 connector for "tico" display, 4 pole

### TECHNICAL DATA electrical

General design	as per DIN EN 61010-1, protection class III, contamination level 2, overvoltage class II
Supply voltage	DC 10-30 V
Max. current w/o load	220 mA (ST), 250 mA (MT)
EMC	EN 61326: Class A



## Absolute

## Profibus

### TECHNICAL DATA electrical (continued)

Resolution singleturn	10 - 14 Bit
Resolution multiturn	12 Bit
Output code	Binary
Drives	RS 485
Linearity	± ½ LSB (± 1 LSB for resolution 13, 14, 25, 26 Bit)
Profile/ protocol	Profibus DP with encoder profile class C2 (parameterizable)
Programmable	Resolution, Preset, Direction
Integrated special functions	Speed, Acceleration, Operating time
Baud rate	is automatically set within a range of 9.6 Kbaud through 12 MBaud
Device address	adjustable with DIP switches, via fieldbus (optional)
Bus termination resistor	set via DIP switches

**STARTUP** (The encoder can be easily and quickly installed and programmed with the GSD file.)

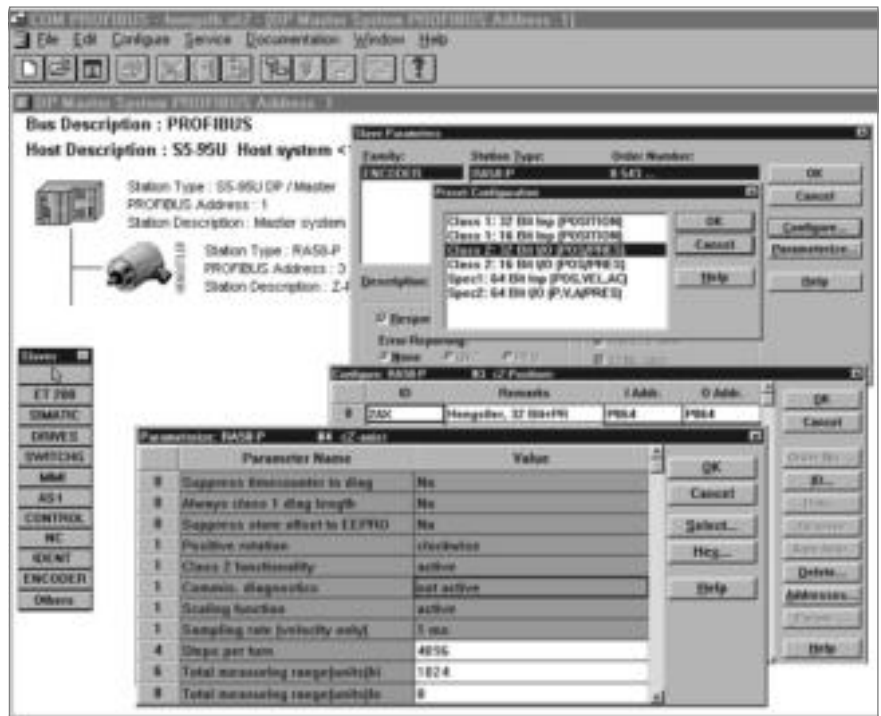

## Absolute

## Profibus

### ELECTRICAL CONNECTIONS

Bus cover with 2x M23 connectors  
(Conin), 12 pole

Pin	IN (pins)	OUT (socket)	Description
1		GND <sup>1</sup>	Data Ground (M5V) <sup>1</sup>
2	A	A	Receive/Transmit Data-Negative (A)
3			
4	B	B	Receive/Transmit Data-Positive (B)
5			
6		VCC <sup>1</sup>	+5 V signal output (P5V) <sup>1</sup>
7	DC 10 - 30 V	DC 10 - 30 V	Supply voltage +U <sub>B</sub> (P24)
8	0 V	0 V	Supply voltage Ground (M24)
9			
10			
11			
12			
screen	screen	screen	screen connected with encoder housing

<sup>1</sup> can be used as power supply for an external bus termination resistor

### ELECTRICAL CONNECTIONS

Bus cover with 3x M12

Pin	Connector 1	Connector 2	Socket
1		UB in	+5 V signal output (P5V) <sup>1</sup>
2	A in		A out
3		0 V in	Data Ground (M5V) <sup>1</sup>
4	B in		B out
5	screen	screen	screen

<sup>1</sup> can be used as power supply for an external bus termination resistor

### ELECTRICAL CONNECTIONS

Bus cover with 3 sealed cable exits

Connecting Terminal	Signal
1	UB in (DC 10 - 30V)
2	0 V in
3	UB out
4	0 V out
5	B in
6	A in
7	B out
8	A out

### DIMENSIONED DRAWINGS

see chapter "Dimensioned drawings AC 58", starting page 185

ORDERING INFORMATION

Type	Resolution	Supply voltage	Flange, Protection, Shaft	Interface	Connection
<input type="checkbox"/>	<input type="text"/>	<input type="checkbox"/>	<input type="text"/>	<input type="checkbox"/>	<input type="text"/>
<b>AC58</b>	<b>0010</b> 10 Bit ST <b>0012</b> 12 Bit ST <b>0013</b> 13 Bit ST <b>0014</b> 14 Bit ST <b>1212</b> 12 Bit MT + 12 Bit ST <b>1213</b> 12 Bit MT + 13 Bit ST <b>1214</b> 12 Bit MT + 14 Bit ST	<b>E</b> DC 10 - 30 V	<b>S.41</b> <b>Synchro, IP64, 6 mm</b> <b>S.71</b> <b>Synchro, IP67, 6 mm</b> <b>K.42</b> <b>Clamping, IP64, 10 mm</b> <b>K.46</b> Clamping, IP64, 9.52 mm <b>K.72</b> <b>Clamping, IP67, 10 mm</b> <b>K.76</b> Clamping, IP67, 9.52 mm <b>F.46</b> Spring tether, IP64, hubs-haft 9.52 mm, mounting with clamping ring front <b>F.42</b> <b>Spring tether, IP64, hubs-haft 10 mm, mounting with clamping ring front</b> <b>F.47</b> <b>Spring tether, IP64, hubs-haft 12 mm, mounting with clamping ring front</b> <b>Q.46</b> Square, IP64, 9.52 mm <b>Q.42</b> Square, IP64, 10 mm <b>Q.76</b> Square, IP67, 9.52 mm <b>Q.72</b> Square, IP67, 10 mm	<b>DP</b> Profibus	<b>I</b> Bus cover with 2x M23 connector (Conin), 12 pole, radial, cw <b>R</b> Bus cover with 3x M12 <b>T</b> Bus cover with 2 sealed cable exits + 1 x M12 connector for "tico" display, 4 pole <b>Z</b> Bus cover with 3 sealed cable exits

Preferably available versions are printed in bold type.

ACCESSORIES

see chapter "Accessories", starting page 322

## Absolute

## CANopen



Clamping flange

- Diagnostic LED
- Programmable: Resolution, Preset, Offset, Direction
- Output of speed, acceleration
- Operation timer
- Option: Display "tico"
- Address and baud rate via interface parameterizable (optional)



CANopen



### TECHNICAL DATA mechanical

Housing diameter	58 mm
Shaft diameter	6 mm / 10 mm (Solid shaft) 10 mm / 12 mm (Hub shaft)
Flange (Mounting of housing)	Synchro flange, Clamping flange, Tether, Square flange
Protection class shaft input (EN 60529)	IP64 or IP67
Protection class housing (EN 60529)	Connection bus cover: IP67 Connection cable or M23 (conin): IP64 (IP67 optional)
Shaft load axial / radial	40 N / 60 N
Axial endplay of mounting shaft (hubshaft)	± 1.5 mm
Radial runout of mating shaft (hubshaft)	± 0.2 mm
Max. speed	max. 10 000 rpm (continuous), max. 12 000 rpm (short term)
Torque	0.5 Ncm
Moment of inertia	ca. $3.8 \times 10^{-6}$ kgm <sup>2</sup>
Vibration resistance (DIN EN 60068-2-6)	100 m/s <sup>2</sup> (10 ... 500 Hz)
Shock resistance (DIN EN 60068-2-27)	1000 m/s <sup>2</sup> (6 ms)
Operating temperature	-40 °C ... +85 °C
Storage temperature	-40 °C ... +85 °C
Material shaft	Stainless Steel
Material housing	Aluminum
Weight	approx. 350 g (ST) / 400 g (MT)
Connection	Cable, axial or radial M23 connector (Conin), 12 pole, axial or radial Bus cover with 3 sealed cable exits Bus cover with 2x M23 connectors (Conin), 9 pole Bus cover with 2 sealed cable exits + 1 x M12 connector for "tico" display, 4 pole

### TECHNICAL DATA electrical

General design	as per DIN EN 61010-1, protection class III, contamination level 2, overvoltage class II
Supply voltage	DC 10-30 V
Max. current w/o load	220 mA (ST), 250 mA (MT)
EMC	EN 61326: Class A

## Absolute

## CANopen

### TECHNICAL DATA electrical (continued)

Resolution singleturn	10 - 16 Bit
Resolution multiturn	12 Bit
Output code	Binary
Linearity	± ½ LSB (± 1 LSB for resolution 13, 14, 25, 26 Bit)
Profile/ protocol	CANopen according to DS 301 with profile DSP 406, programmable encoder according class C2
Programmable	Resolution, Preset, Offset, Direction
Integrated special functions	Speed, Acceleration, Limit values, Operating time
Baud rate	set via DIP switches within a range of 10 through 1000 Kbit/s
Bus termination resistor	set via DIP switches
Updating of values	every millisecond (adjustable), on request
Basic identifier	set via DIP switches

### ELECTRICAL CONNECTIONS Bus cover with 2x M23 connectors (Conin), 9 pole

M23-PIN (Conin)	Pin insert (IN)	Socket insert (OUT)
1	CAN in +	CAN out +
2	CAN in -	CAN out-
3	CAN GND in	CAN GND out
4	N.C.	N.C.
5	N.C.	N.C.
6	N.C.	N.C.
7	UB in	UB out
8	0 V in	0 V out
9	N.C.	N.C.
screen	screen <sup>1</sup>	screen <sup>1</sup>

<sup>1</sup> screen connected with encoder housing

### ELECTRICAL CONNECTIONS M23 connector (Conin), 12 pole / cable

M23-Pin (Conin)	TPE cable	Cable pairs	Signal
7	yellow	Pair 1	CAN in+
2	green		CAN in -
4	pink	Pair 2	CAN out +
5	grey		CAN out -
3	blue		CAN GND in
11	brown		CAN GND out
12	white	Pair 3	UB in
10	brown		0 V in
screen	screen		screen

## Absolute

## CANopen

**ELECTRICAL CONNECTIONS**  
**Bus cover with 3 sealed cable exits**

### Connecting block KL 1 (10 pole)

No.	Signal name
1	UB in (DC 10-30V)
2	0 V in
3	CAN in - (dominant L)
4	CAN in + (dominant H)
5	CAN GND in
6	CAN GND out
7	CAN out + (dominant H)
8	CAN out - (dominant L)
9	0 V out
10	UB out (DC 10-30V)

**DIMENSIONED DRAWINGS**

see chapter "Dimensioned drawings AC 58", starting page 185

**ORDERING INFORMATION**

Type	Resolution	Supply voltage	Flange, Protection, Shaft <sup>1</sup>	Interface	Connection
<input type="checkbox"/>	<input type="text"/>	<input type="checkbox"/>	<input type="checkbox"/>	<input type="checkbox"/>	<input type="checkbox"/>
<b>AC58</b>	<b>0010</b> 10 Bit ST <b>0012</b> 12 Bit ST <b>0013</b> 13 Bit ST <b>0014</b> 14 Bit ST <b>0016</b> 16 Bit ST <b>1212</b> 12 Bit MT + 12 Bit ST <b>1213</b> 12 Bit MT + 13 Bit ST <b>1214</b> 12 Bit MT + 14 Bit ST	E DC 10 - 30 V	<b>S.41</b> <b>Synchro, IP64, 6 mm</b> <b>S.71</b> <b>Synchro, IP67, 6 mm</b> <b>K.42</b> <b>Clamping, IP64, 10 mm</b> <b>K.46</b> Clamping, IP64, 9.52 mm <b>K.72</b> <b>Clamping, IP67, 10 mm</b> <b>K.76</b> Clamping, IP67, 9.52 mm <b>F.46</b> Spring tether, IP64, hubs-haft 9.52 mm, mounting with clamping ring front <b>F.42</b> <b>Spring tether, IP64, hubs-haft 10 mm, mounting with clamping ring front</b> <b>F.47</b> <b>Spring tether, IP64, hubs-haft 12 mm, mounting with clamping ring front</b> <b>Q.46</b> Square, IP64, 9.52 mm <b>Q.42</b> Square, IP64, 10 mm <b>Q.76</b> Square, IP67, 9.52 mm <b>Q.72</b> Square, IP67, 10 mm	<b>OL</b> CANopen <b>OC</b> CANopen - on request -	<b>A</b> Cable, axial <b>B</b> Cable, radial <b>C</b> <b>M23 connector (Conin), 12 pole, axial, cw</b> <b>D</b> <b>M23 connector (Conin), 12 pole, radial, cw</b> <b>G</b> M23 connector (Conin), 12 pole, axial, ccw <b>H</b> M23 connector (Conin), 12 pole, radial, ccw <b>I</b> Bus cover with 2x M23 connector (Conin), 9 pole, radial, cw <b>T</b> <b>Bus cover with 2 sealed cable exits + 1 x M12 connector for "tico" display, 4 pole</b> <b>Z</b> <b>Bus cover with 2 sealed cable exits</b>

<sup>1</sup> Protection class IP67 in combination with connection "A" - "H": Version without DIP switches and LED. Setting over fieldbus

**Preferably available versions are printed in bold type.**

**Absolute****CANopen****ORDERING INFORMATION****Selection of cable length**

Versions with cable outlet (connection A, B, E or F) are available with various lengths of cable. To order your desired cable length, please add the respective code to the end of your ordering code. Further cable lengths on request.

<b>Code</b>	<b>Cable length</b>
without code	1.5 m
-D0	3 m
-F0	5 m
-K0	10 m
-P0	15 m
-U0	20 m
-V0	25 m

**ACCESSORIES**

see chapter "Accessories", starting page 322

## Absolute

## CANlayer2



Clamping flange

### TECHNICAL DATA mechanical

- Diagnostic LED
- Poll and auto mode
- Programmable: Direction, limit values
- Option: Display "tico"



Housing diameter	58 mm
Shaft diameter	6 mm / 10 mm (Solid shaft) 10 mm / 12 mm (Hub shaft)
Flange (Mounting of housing)	Synchro flange, Clamping flange, Tether, Square flange
Protection class shaft input (EN 60529)	IP64 or IP67
Protection class housing (EN 60529)	IP67 or IP64 (IP67 optional)
Shaft load axial / radial	40 N / 60 N
Axial endplay of mounting shaft (hubshaft)	± 1.5 mm
Radial runout of mating shaft (hubshaft)	± 0.2 mm
Max. speed	max. 10 000 rpm (continuous), max. 12 000 rpm (short term)
Torque	0.5 Ncm
Moment of inertia	ca. $3.8 \times 10^{-6}$ kgm <sup>2</sup>
Vibration resistance (DIN EN 60068-2-6)	100 m/s <sup>2</sup> (10 ... 500 Hz)
Shock resistance (DIN EN 60068-2-27)	1000 m/s <sup>2</sup> (6 ms)
Operating temperature	-40 °C ... +85 °C
Storage temperature	-40 °C ... +85 °C
Material shaft	Stainless Steel
Material housing	Aluminum
Weight	approx. 350 g (ST) / 400 g (MT)
Connection	Cable, axial or radial M23 connector (Conin), 12 pole, axial or radial Bus cover with 3 sealed cable exits Bus cover with 2x M23 connectors (Conin), 9 pole Bus cover with 2 sealed cable exits + 1 x M12 connector for "tico" display, 4 pole

### TECHNICAL DATA electrical

General design	as per DIN EN 61010-1, protection class III, contamination level 2, overvoltage class II
Supply voltage	DC 10-30 V
Max. current w/o load	220 mA (ST), 250 mA (MT)
EMC	EN 61326: Class A
Resolution singleturn	10 - 14 Bit



## Absolute

## CANlayer2

### TECHNICAL DATA electrical (continued)

Resolution multitrans	12 Bit
Output code	Binary
Linearity	$\pm \frac{1}{2}$ LSB ( $\pm 1$ LSB for resolution 13, 14, 25, 26 Bit)
Profile/ protocol	CAN 2.0 A
Programmable	Direction, Limit values
Baud rate	set via DIP switches within a range of 10 through 1000 Kbit/s
Bus termination resistor	set via DIP switches
Updating of values	every millisecond
Basic identifier	set via DIP switches

### ELECTRICAL CONNECTIONS Bus cover with 2x M23 connectors (Conin), 9 pole

M23-PIN (Conin)	Pin insert (IN)	Socket insert (OUT)
1	CAN in +	CAN out +
2	CAN in -	CAN out-
3	CAN GND in	CAN GND out
4	N.C.	N.C.
5	N.C.	N.C.
6	N.C.	N.C.
7	UB in	UB out
8	0 V in	0 V out
9	N.C.	N.C.
screen	screen <sup>1</sup>	screen <sup>1</sup>

<sup>1</sup> screen connected with encoder housing

### ELECTRICAL CONNECTIONS M23 connector (Conin), 12 pole / cable

M23-Pin (Conin)	TPE cable	Cable pairs	Signal
7	yellow	Pair 1	CAN in+
2	green		CAN in -
4	pink	Pair 2	CAN out +
5	grey		CAN out -
3	blue		CAN GND in
11	brown		CAN GND out
12	white	Pair 3	UB in
10	brown		0 V in
screen	screen		screen

Absolute

CANlayer2

**ELECTRICAL CONNECTIONS**  
 Bus cover with 3 sealed cable exits

Connecting block KL 1 (10 pole)	
No.	Signal name
1	UB in (DC 10-30V)
2	0 V in
3	CAN in - (dominant L)
4	CAN in + (dominant H)
5	CAN GND in
6	CAN GND out
7	CAN out + (dominant H)
8	CAN out - (dominant L)
9	0 V out
10	UB out (DC 10-30V)

**DIMENSIONED DRAWINGS**

see chapter "Dimensioned drawings AC 58", starting page 185

**ORDERING INFORMATION**

Type	Resolution	Supply voltage	Flange, Protection, Shaft <sup>1</sup>	Interface	Connection
<input type="checkbox"/>	<input type="text"/>	<input type="checkbox"/>	<input type="checkbox"/>	<input type="checkbox"/>	<input type="checkbox"/>
<b>AC58</b>	<b>0010</b> 10 Bit ST <b>0012</b> 12 Bit ST <b>0013</b> 13 Bit ST <b>0014</b> 14 Bit ST <b>1212</b> 12 Bit MT + 12 Bit ST <b>1213</b> 12 Bit MT + 13 Bit ST <b>1214</b> 12 Bit MT + 14 Bit ST	E DC 10 - 30 V	<b>S.41</b> Synchro, IP64, 6 mm <b>S.71</b> Synchro, IP67, 6 mm <b>K.42</b> Clamping, IP64, 10 mm <b>K.46</b> Clamping, IP64, 9.52 mm <b>K.72</b> Clamping, IP67, 10 mm <b>K.76</b> Clamping, IP67, 9.52 mm <b>F.46</b> Spring tether, IP64, hubs-haft 9.52 mm, mounting with clamping ring front <b>F.42</b> Spring tether, IP64, hubs-haft 10 mm, mounting with clamping ring front <b>F.47</b> Spring tether, IP64, hubs-haft 12 mm, mounting with clamping ring front <b>Q.46</b> Square, IP64, 9.52 mm <b>Q.42</b> Square, IP64, 10 mm <b>Q.76</b> Square, IP67, 9.52 mm <b>Q.72</b> Square, IP67, 10 mm	CL CANLayer2	<b>A</b> Cable, axial <b>B</b> Cable, radial <b>C</b> M23 connector (Conin), 12 pole, axial, cw <b>D</b> M23 connector (Conin), 12 pole, radial, cw <b>G</b> M23 connector (Conin), 12 pole, axial, ccw <b>H</b> M23 connector (Conin), 12 pole, radial, ccw <b>I</b> Bus cover with 2x M23 connector (Conin), 9 pole, radial, cw <b>T</b> Bus cover with 2 sealed cable exits + 1 x M12 connector for "tico" display, 4 pole <b>Z</b> Bus cover with 2 sealed cable exits

<sup>1</sup> Protection class IP67 not available in combination with cable and M23 connector (Conin) for connection code "A" - "H"

Preferably available versions are printed in bold type.

**Absolute****CANlayer2****ORDERING INFORMATION**  
Selection of cable length

Versions with cable outlet (connection A, B, E or F) are available with various lengths of cable. To order your desired cable length, please add the respective code to the end of your ordering code. Further cable lengths on request.

<b>Code</b>	<b>Cable length</b>
without code	1.5 m
-D0	3 m
-F0	5 m
-K0	10 m
-P0	15 m
-U0	20 m
-V0	25 m

**ACCESSORIES**

see chapter "Accessories", starting page 322

## Absolute

## DeviceNet



Synchro flange

- Programmable: Resolution, Preset, Direction
- Allan-Bradley compatible
- Scalable
- Preset function
- Diagnostic LED
- Option: Display "tico"



### TECHNICAL DATA mechanical

Housing diameter	58 mm
Shaft diameter	6 mm / 10 mm (Solid shaft) 10 mm / 12 mm (Hub shaft)
Flange (Mounting of housing)	Synchro flange, Clamping flange, Tether, Square flange
Protection class shaft input (EN 60529)	IP64 or IP67
Protection class housing (EN 60529)	IP67
Shaft load axial / radial	40 N / 60 N
Axial endplay of mounting shaft (hubshaft)	± 1.5 mm
Radial runout of mating shaft (hubshaft)	± 0.2 mm
Max. speed	max. 10 000 rpm (continuous), max. 12 000 rpm (short term)
Torque	0.5 Ncm
Moment of inertia	ca. $3.8 \times 10^{-6}$ kgm <sup>2</sup>
Vibration resistance (DIN EN 60068-2-6)	100 m/s <sup>2</sup> (10 ... 500 Hz)
Shock resistance (DIN EN 60068-2-27)	1000 m/s <sup>2</sup> (6 ms)
Operating temperature	-40 °C ... +85 °C
Storage temperature	-40 °C ... +85 °C
Material shaft	Stainless Steel
Material housing	Aluminum
Weight	approx. 350 g (ST) / 400 g (MT)
Connection	Bus cover with 2 sealed cable exits Bus cover with 2 sealed cable exits + 1 x M12 connector for "tico" display, 4 pole Bus cover with 1x M12 connectors (Conin), 5 pole

### TECHNICAL DATA electrical

General design	as per DIN EN 61010-1, protection class III, contamination level 2, overvoltage class II
Supply voltage	DC 10-30 V
Max. current w/o load	220 mA (ST), 250 mA (MT)
EMC	Noise emission according to EN 50081-2 Immunity to interference according to EN 50082-2

## Absolute

## DeviceNet

### TECHNICAL DATA electrical (continued)

EMC	EN 61326: Class A
Resolution singleturn	10 - 14 Bit
Resolution multiturn	12 Bit
Output code	Binary
Interface	CAN High-Speed according to ISO/DIS 11898 CAN specification 2.0 A (11-Bit-Identifier)
Linearity	± ½ LSB (± 1 LSB for resolution 13, 14, 25, 26 Bit)
Profile/ protocol	DeviceNet according to Rev. 2.0, programmable encoder
Programmable	Resolution, Preset, Direction
Baud rate	set via DIP switches to 125, 250, 500 KBAud
Bus termination resistor	set via DIP switches
Updating of values	every 5 Milliseconds
MAC-ID	set via DIP switches

### RECOMMENDED DATA TRANSFER Lead type A

Shaft resistance	135...165 Ω (3...20MHz)
Operating capacity	< 30pF/m
Loop impedance	< 110 Ω/km
Strand diameter	> 0.64 mm
Strand cross section	> 0.34 mm <sup>2</sup>

### Transfer speeds

Segment length	kbit/s
500 m	125
250 m	250
100 m	500

### STARTUP (the encoder can be easily and quickly installed and programmed with the EDS file)

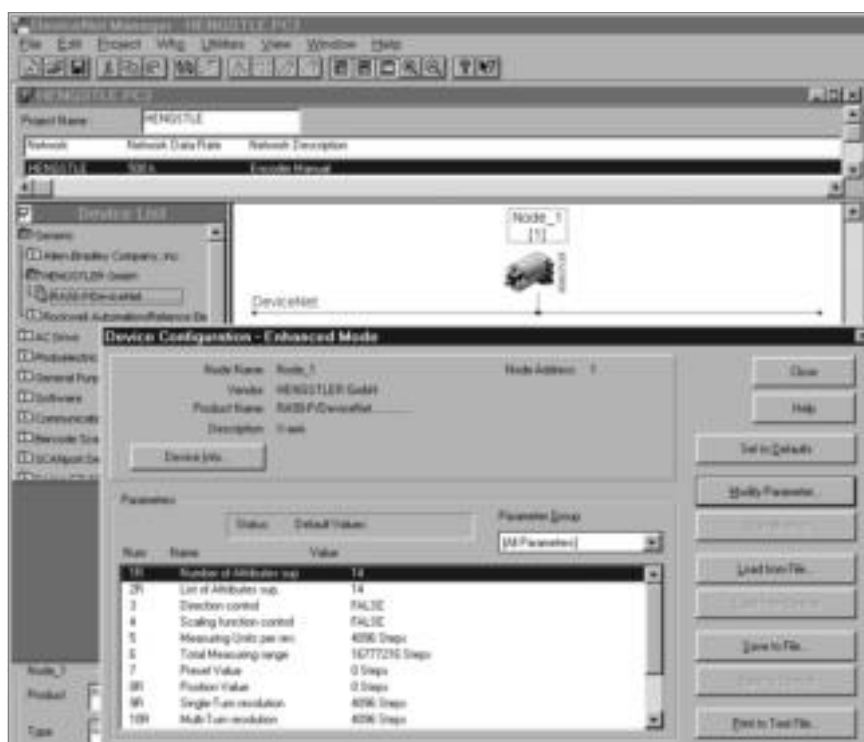

## Absolute

## DeviceNet

**ELECTRICAL CONNECTIONS**  
 Bus cover with 2 sealed cable exits

Terminals	
No.	Signal name
1	UB in (DC 10 - 30V)
2	0 V in
3	CAN-L
4	CAN-H
5	DRAIN
6	DRAIN
7	DRAIN
8	CAN-L
9	0 V out
10	UB out (DC 10 - 30V)

**ELECTRICAL CONNECTIONS**  
 Bus cover with 1x M12, 5 pole

Pin	Connector	Colour
1	UB in (DC 10 - 30V)	white
2	0 V in	blue
3	CAN-L	green/yellow
4	CAN-H	black
5	DRAIN	brown

**DIMENSIONED DRAWINGS**

see chapter "Dimensioned drawings AC 58", starting page 185

ORDERING INFORMATION

Type	Resolution	Supply voltage	Flange, Protection, Shaft	Interface	Connection
<input type="checkbox"/>	<input type="checkbox"/>	<input type="checkbox"/>	<input type="checkbox"/>	<input type="checkbox"/>	<input type="checkbox"/>
<b>AC58</b>	<b>0010</b> 10 Bit ST <b>0012</b> 12 Bit ST <b>0013</b> 13 Bit ST <b>0014</b> 14 Bit ST <b>1212</b> 12 Bit MT + 12 Bit ST <b>1213</b> 12 Bit MT + 13 Bit ST <b>1214</b> 12 Bit MT + 14 Bit ST	<b>E</b> DC 10 - 30 V	<b>S.41</b> Synchro, IP64, 6 mm <b>S.71</b> Synchro, IP67, 6 mm <b>K.42</b> Clamping, IP64, 10 mm <b>K.46</b> Clamping, IP64, 9.52 mm <b>K.72</b> Clamping, IP67, 10 mm <b>K.76</b> Clamping, IP67, 9.52 mm <b>F.46</b> Spring tether, IP64, hubs-haft 9.52 mm, mounting with clamping ring front <b>F.42</b> Spring tether, IP64, hubs-haft 10 mm, mounting with clamping ring front <b>F.47</b> Spring tether, IP64, hubs-haft 12 mm, mounting with clamping ring front <b>Q.46</b> Square, IP64, 9.52 mm <b>Q.42</b> Square, IP64, 10 mm <b>Q.76</b> Square, IP67, 9.52 mm <b>Q.72</b> Square, IP67, 10 mm	<b>VD</b> DeviceNet	<b>S</b> Bushaube mit 1x M12-Stecker, 5-polig, radial <b>T</b> Bus cover with 2 sealed cable exits + 1 x M12 connector for "tico" display, 4 pole <b>Z</b> Bus cover with 2 sealed cable exits

Preferably available versions are printed in bold type.

ACCESSORIES

see chapter "Accessories", starting page 322

## Absolute

## Interbus



hubshaft with tether

- Resolution programmable (K3)
- Resolution up to 24 Bit
- Preset (K3)
- Direction (K3)
- Diagnostic LED



### TECHNICAL DATA mechanical

Housing diameter	58 mm
Shaft diameter	6 mm / 10 mm (Solid shaft) 10 mm / 12 mm (Hub shaft)
Flange (Mounting of housing)	Synchro flange, Clamping flange, Tether, Square flange
Protection class shaft input (EN 60529)	IP64 or IP67
Protection class housing (EN 60529)	Connection bus cover: IP67 Connection cable or M23 (conin): IP64 (IP67 optional)
Shaft load axial / radial	40 N / 60 N
Max. speed	max. 10 000 rpm (continuous), max. 12 000 rpm (short term)
Torque	0.5 Ncm
Moment of inertia	ca. $3.8 \times 10^{-6}$ kgm <sup>2</sup>
Vibration resistance (DIN EN 60068-2-6)	100 m/s <sup>2</sup> (10 ... 500 Hz)
Shock resistance (DIN EN 60068-2-27)	1000 m/s <sup>2</sup> (6 ms)
Operating temperature	-40 °C ... +70 °C
Storage temperature	-40 °C ... +85 °C
Material shaft	Stainless Steel
Material housing	Aluminum
Weight	approx. 350 g (ST) / 400 g (MT)
Connection	Bus cover with 3 sealed cable exits Bus cover with 2x M23 connectors (Conin), 9 pole Cable 1.5 m with M23 connector (Conin), 12 pole, axial or radial

### TECHNICAL DATA electrical

General design	as per DIN EN 61010-1, protection class III, contamination level 2, overvoltage class II
Supply voltage	DC 10-30 V
Max. current w/o load	220 mA (ST, recommended external fuse: T 0.25 A), 250 mA (MT, recommended external fuse: T 0.25 A)
EMC	Noise emission according to EN 50081-2 Immunity to interference according to EN 50082-2
Resolution singleturn	10 - 12 Bit
Resolution multiturn	12 Bit
Output code	32 Bit binary
Linearity	$\pm \frac{1}{2}$ LSB



## Absolute

## Interbus

### TECHNICAL DATA electrical (continued)

Profile/ protocol	ENCOM-Profil K3 = ID-Code 37, K2 = ID-Code 36
Programmable	Resolution, Preset, Offset, Direction
Output current <sup>1</sup>	max. 4.5 A for bus cover with 2x M23 (recommended external fuse: T 4.5 A) max. 2 A for all other connections (recommended external fuse: T 2 A)
Baud rate	500 KBaud
Updating of values	every 600 µs

<sup>1</sup> Current with looped through voltage supply

### DATA FORMAT Interbus K2/K3

	Differential signals (RS485) ENCOM profile K3, K2, 32 Bit, binary process data				
Data format	µpi-address	0	1	2	3
(as per Phoenix)	Byte-No.	3	2	1	0
ID-Code K2	36H (= 54 decimal)				
ID-Code K3	37H (= 55 decimal)				

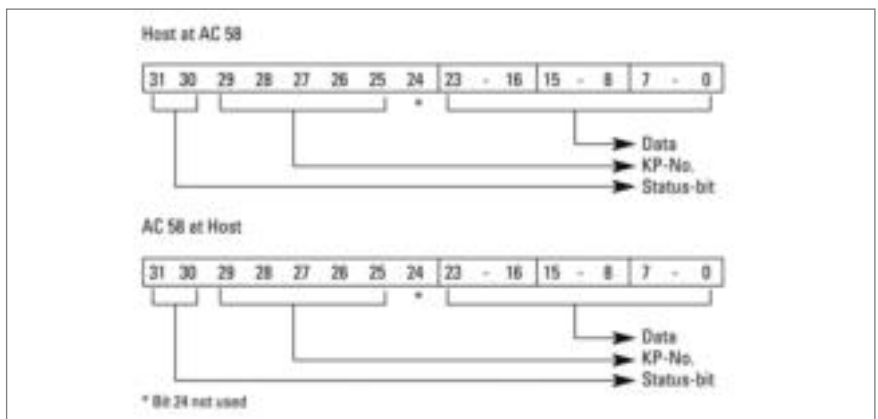

### PROGRAMMABLE FUNKTIONS for Interbus K3

Function (Programming directly via the bus through transfer of configuration parameters)	Preset values (manufacturer's standard settings)	Customer-specific parameters
Code sequence for clockwise (cw) rotation	ascending	
Offset (KP-No. 05)	0	
Preset value (KP-No. 04)	0	
Scaling faktor (KP-No. 08)	1 <sup>1</sup>	

<sup>1</sup> maximum resolution

## Absolute

## Interbus

### ELECTRICAL CONNECTIONS

Cable with M23 connector (Conin), 12 pole  
(Standard according to ENCOM for remote installation bus)

Plug pin	Signal
1	D02
2	$\overline{D02}$
3	DI 2
4	$\overline{DI 2}$
5	D01
6	$\overline{D01}$
7	DI 1
8	$\overline{DI1}$
9	$\overline{RBST}$
10	GND- signal output <sup>1</sup>
11	0 V (supply voltage)
12	DC 10 - 30 V

<sup>1</sup> Due to electrical isolation not identical with 0 V (supply voltage) identisch; used by T-manifold to set the RBST input logical on "0"

### ELECTRICAL CONNECTIONS

Bus cover with 2x M23 connector (Conin), 9 pole  
(Standard according to ENCOM for remote installation bus)

Pin	IN (9 pole pins)	OUT (9 pole socket)
1	D01	D02
2	$\overline{D01}$	$\overline{D02}$
3	DI 1	DI 2
4	$\overline{DI1}$	$\overline{DI2}$
5	GND- signal output <sup>1</sup>	GND- signal output <sup>1</sup>
6	PE <sup>2</sup>	PE <sup>2</sup>
7	DC10 - 30 V (SELV)	DC10 - 30 V (SELV)
8	0 V (supply voltage)	0 V (supply voltage)
9	N.C.	$\overline{RBST}$

<sup>1</sup> Due to electrical isolation not identical with 0 V (supply voltage) identisch; used by T-manifold to set the RBST input logical on "0"

<sup>2</sup> Functional earthing; connected with the encoder housing

### ELECTRICAL CONNECTIONS

Bus cover with 3 sealed cable exits

Connection clamp (12 pole)	
1	UB +
2	GND
3	DI1+
4	DI1-
5	D01+
6	D01-
7	D02+
8	D02-
9	DI2+
10	DI2-
11	RBST
12	GND

## Absolute

## Interbus

### DIMENSIONED DRAWINGS

see chapter "Dimensioned drawings AC 58", starting page 185

### ORDERING INFORMATION

Type	Resolution	Supply voltage	Flange, Protection, Shaft <sup>1</sup>	Interface	Connection
<input type="checkbox"/>	<input type="text"/>	<input type="checkbox"/>	<input type="text"/>	<input type="checkbox"/>	<input type="text"/>
<b>AC58</b>	<b>0010</b> 10 Bit ST <b>0012</b> 12 Bit ST <b>1212</b> 12 Bit MT + 12 Bit ST	<b>E</b> DC 10 - 30 V	<b>S.41</b> Synchro, IP64, 6 mm <b>S.71</b> Synchro, IP67, 6 mm <b>K.42</b> Clamping, IP64, 10 mm <b>K.46</b> Clamping, IP64, 9.52 mm <b>K.72</b> Clamping, IP67, 10 mm <b>K.76</b> Clamping, IP67, 9.52 mm <b>F.46</b> Spring tether, IP64, hubs-haft 9.52 mm, mounting with clamping ring front <b>F.42</b> Spring tether, IP64, hubs-haft 10 mm, mounting with clamping ring front <b>F.47</b> Spring tether, IP64, hubs-haft 12 mm, mounting with clamping ring front <b>Q.46</b> Square, IP64, 9.52 mm <b>Q.42</b> Square, IP64, 10 mm <b>Q.76</b> Square, IP67, 9.52 mm <b>Q.72</b> Square, IP67, 10 mm	<b>I2</b> Interbus K2 <b>K3</b> Interbus K3	<b>I</b> Bus cover with 2x M23 connector (Conin), 9 pole, radial, cw <b>Z</b> Bus cover with 3 sealed cable exits <b>A-B5-C</b> 1.5 m cable with M23 connector (Conin), 12 pole, axial <b>B-B5-C</b> 1.5 m cable with M23 connector (Conin), 12 pole, radial

<sup>1</sup> Protection class IP67 not available in combination with LED display for connection with cable (connection code A-B5-C and B-B5-C)

Preferably available versions are printed in bold type.

### ACCESSORIES

see chapter "Accessories", starting page 322

## Absolute

## SUCOnet



Clamping flange

### TECHNICAL DATA mechanical

- Compact design
- SUCOnet or Hengstler-G1-Protocol
- Parameterizable: preset, direction, scaling factor, resolution
- PC communication via RS 485 with Hengstler-G1-Protocol



Housing diameter	58 mm
Shaft diameter	6 mm / 10 mm (Solid shaft) 10 mm / 12 mm (Hubshaft)
Flange (Mounting of housing)	Synchro flange, Clamping flange, Tether, Square flange
Protection class shaft input (EN 60529)	IP64 or IP67
Protection class housing (EN 60529)	IP64
Shaft load axial / radial	40 N / 60 N
Max. speed	max. 6000 rpm (continuous), max. 12000 rpm (short term)
Torque	0.5 Ncm
Vibration resistance (DIN EN 60068-2-6)	100 m/s <sup>2</sup>
Shock resistance (DIN EN 60068-2-27)	1000 m/s <sup>2</sup>
Operating temperature	-10 °C ... +60 °C
Storage temperature	-25 °C ... +85 °C
Material shaft	Stainless Steel
Material housing	Aluminum
Weight	approx. 260 g (ST) / 310 g (MT)
Connection	Cable, axial or radial

### TECHNICAL DATA electrical

Supply voltage	DC 10-30 V
Max. current w/o load	200 mA
EMC	EN 61326: class A
Resolution singleturn	10 - 13 Bit
Resolution multiturn	12 Bit
Output code	Binary
Drives	RS485
Linearity	± ½ LSB (± 1 LSB for resolution 13 and 25 Bit)
Profile/ protocol	SUCOnet-K1 or Hengstler-G1
Programmable	Resolution, Direction
Address switch	set via DIP switches
Bus termination resistor	set via DIP switches

## Absolute

## SUCOnet

### DIMENSIONED DRAWINGS

see chapter "Dimensioned drawings AC 58", starting page 185

### ORDERING INFORMATION

Type	Resolution	Supply voltage	Flange, Protection, Shaft	Interface	Connection
<input type="checkbox"/>	<input type="text"/>	<input type="checkbox"/>	<input type="checkbox"/>	<input type="checkbox"/>	<input type="checkbox"/>
<b>AC58</b>	<b>0010</b> 10 Bit ST <b>0012</b> 12 Bit ST <b>0013</b> 13 Bit ST <b>1210</b> 12 Bit MT + 10 Bit ST <b>1212</b> 12 Bit MT + 12 Bit ST <b>1213</b> 12 Bit MT + 13 Bit ST	<b>E</b> DC 10 - 30 V	<b>S.41</b> <b>Synchro, IP64, 6 mm</b> <b>K.42</b> <b>Clamping, IP64, 10 mm</b> <b>K.46</b> Clamping, IP64, 9.52 mm <b>F.46</b> Spring tether, IP64, hubs-haft 9.52 mm, mounting with clamping ring front <b>F.42</b> <b>Spring tether, IP64, hubs-haft 10 mm, mounting with clamping ring front</b> <b>F.47</b> <b>Spring tether, IP64, hubs-haft 12 mm, mounting with clamping ring front</b> <b>Q.46</b> Square, IP64, 9.52 mm <b>Q.42</b> Square, IP64, 10 mm	<b>RS</b> Hengstler-G1-Protocol <b>US</b> SUCOnet	<b>A</b> Cable, axial <b>B</b> Cable, radial

Preferably available versions are printed in bold type.

### ORDERING INFORMATION

#### Selection of cable length

Versions with cable outlet (connection A, B, E or F) are available with various lengths of cable. To order your desired cable length, please add the respective code to the end of your ordering code. Further cable lengths on request.

Code	Cable length
without code	1.5 m
-D0	3 m
-F0	5 m
-K0	10 m
-P0	15 m
-U0	20 m
-V0	25 m

### ACCESSORIES

see chapter "Accessories", starting page 322

**Absolute**

**SSI programmable**



hubshaft with tether

- Compact design: 59 mm mounting depth for single or multiturn
- Aids for start up and operation: diagnostic LED, preset key with optical response
- Parameterization: Resolution, code type, direction, output format, warning, alarm
- Parameters can be stored in a non-volatile memory
- Integrated RS232 interface



**TECHNICAL DATA**  
mechanical

Housing diameter	58 mm
Shaft diameter	6 mm / 10 mm (Solid shaft) 10 mm / 12 mm (Hub shaft)
Flange (Mounting of housing)	Synchro flange, Clamping flange, Tether, Square flange
Protection class shaft input (EN 60529)	IP64 or IP67
Protection class housing (EN 60529)	IP64 (IP67 optional)
Shaft load axial / radial	40 N / 60 N
Max. speed	max. 10 000 rpm (continuous), max. 12 000 rpm (short term)
Torque	0.5 Ncm
Moment of inertia	ca. $3.8 \times 10^{-6}$ kgm <sup>2</sup>
Vibration resistance (DIN EN 60068-2-6)	100 m/s <sup>2</sup> (10 ... 500 Hz)
Shock resistance (DIN EN 60068-2-27)	1000 m/s <sup>2</sup> (6 ms)
Operating temperature	-40 °C ... +100 °C
Storage temperature	-40 °C ... +85 °C
Material shaft	Stainless Steel
Material housing	Aluminum
Weight	approx. 260 g (ST) / 310 g (MT)
Connection	Cable, axial or radial M23 connector (Conin), 12 pole, axial or radial

**TECHNICAL DATA**  
electrical

Supply voltage	DC 10-30 V
Max. current w/o load	250 mA (ST / MT)
Resolution singleturn	10 - 17 Bit
Resolution multiturn	12 Bit
Output code	Binary, Gray
Drives	Clock and Data / RS422
Parametrization	Resolution, Code type, Direction, Output format, Warning, Alarm
Control inputs	Direction, Preset 1, Preset 2
Alarm output	Alarm bit
Status LED	Green = ok, red = alarm

**Absolute**

**SSI programmable**

**RECOMMENDED DATA TRANSFER RATE bei SSI**

The max. data transfer rate depends on the cable length. For Clock /  $\overline{\text{Clock}}$  and Data /  $\overline{\text{Data}}$  please use twisted pairs. Use shielded cable.

Cable length	Frequency
< 50 m	< 400 kHz
< 100 m	< 300 kHz
< 200 m	< 200 kHz
< 400 m	< 100 kHz

**SYNCHRONOUS-SERIAL TRANSFER (SSI)**

A clock brush is applied at the SSI interface, causing the encoder data to be serially clocked out. With each new clock brush (min. interval 30 ms) new data is readout. The following main parameters are programmable:

- Preset: Software-Preset and via input/pushbutton settable presets (can be inactivated)
- Offset: Relative shifting of actual encoder value.
- Scaling: The actual value of the encoder is multiplied with the factor < 1 (direct entry, increments per measuring distance or per revolution).
- Direction of rotation: Can be changed via software or input (can be inactivated)

- Output formats SSI: Tree format or standard format (MSB oriented)
- Output code: The choices are Gray or binary code, integer or two's complement representation. Selection of significant bit between 16 and 24 Bit.

In addition, programming of max. 7 status bits is possible:

- up to 4 warning positions
- overspeed
- encoder standstill
- parity
- encoder error
- direction of rotation

**PROGRAMMING with SSI**

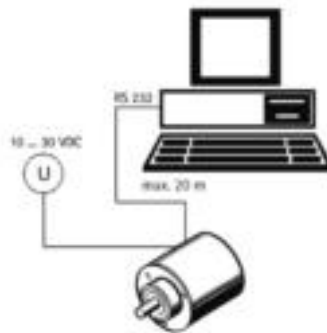

To program the absolute encoder you require a PC, the software WinSSI and the adapter cable.

The encoder is connected to the power supply and the serial interface of your PC with the adapter cable. Using the menu-assisted programme you can then configure the encoder according to the parameters you require.

OUTPUT FORMAT SSI, MSB oriented, Multiturn

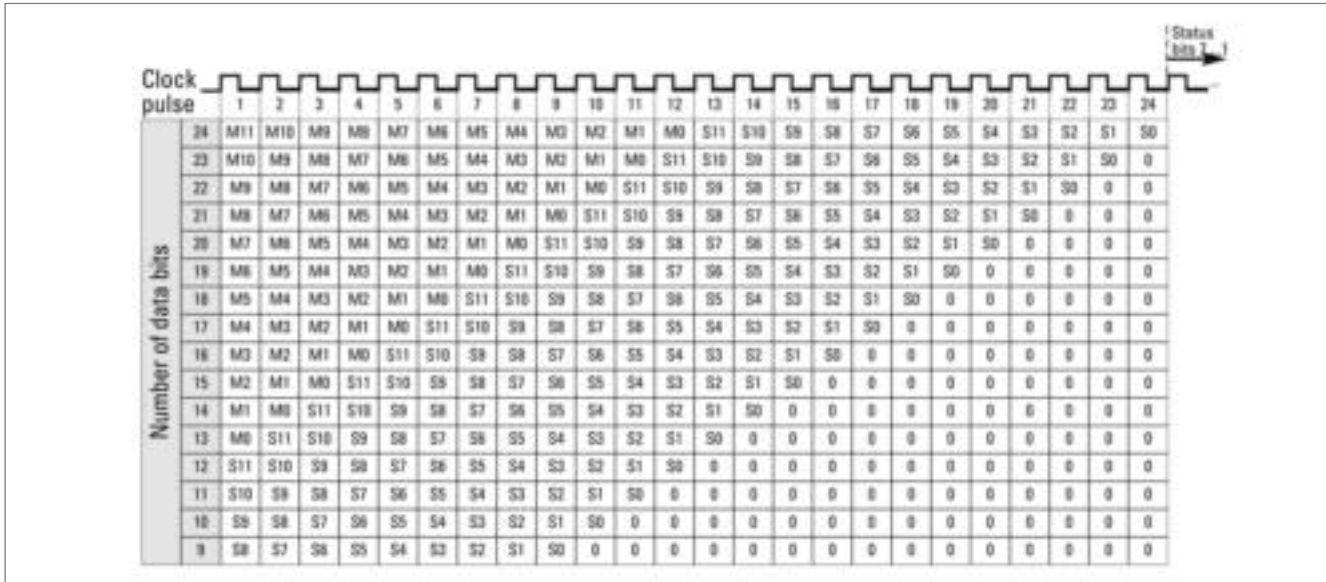

OUTPUT FORMATS SSI, MSB oriented, Multiturn (not scaleable)

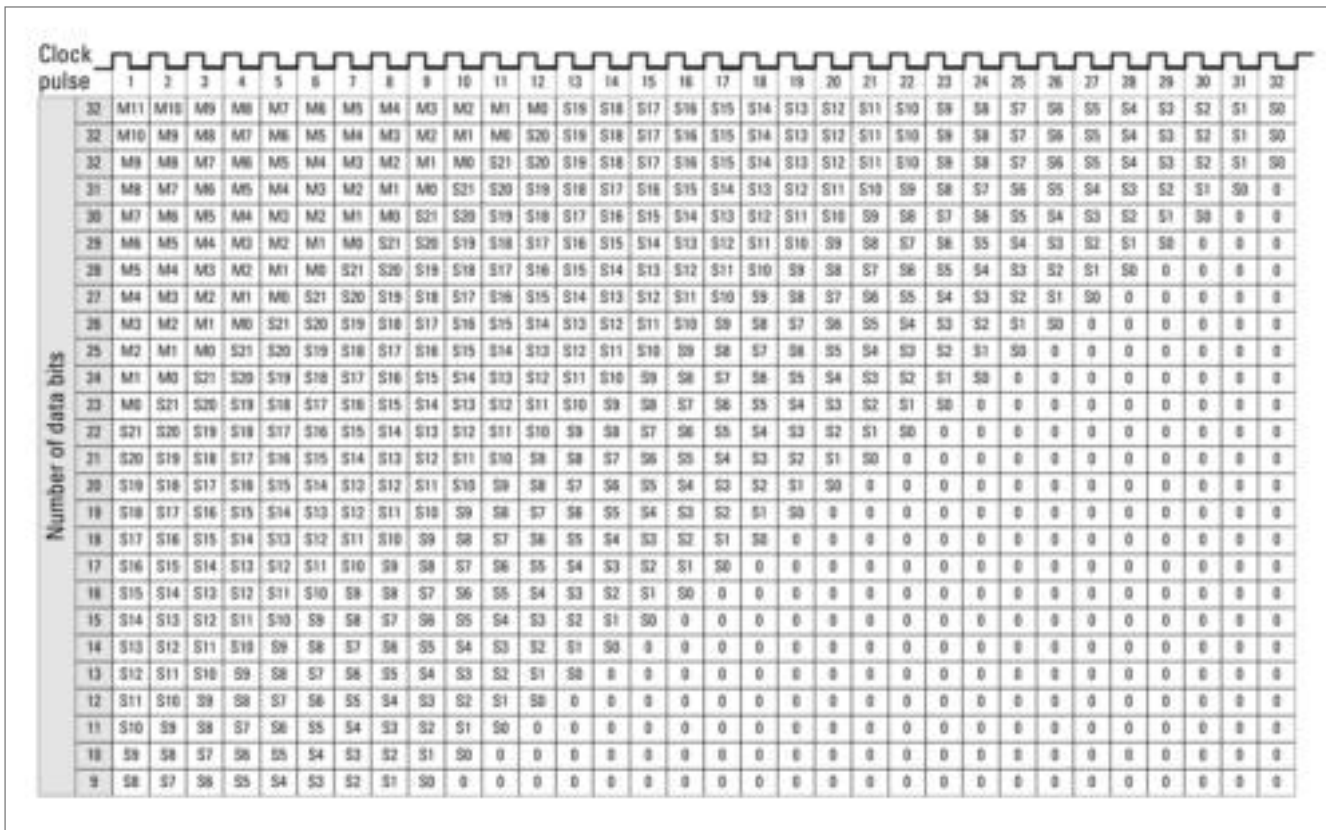



### OUTPUT FORMAT SSI, tree format

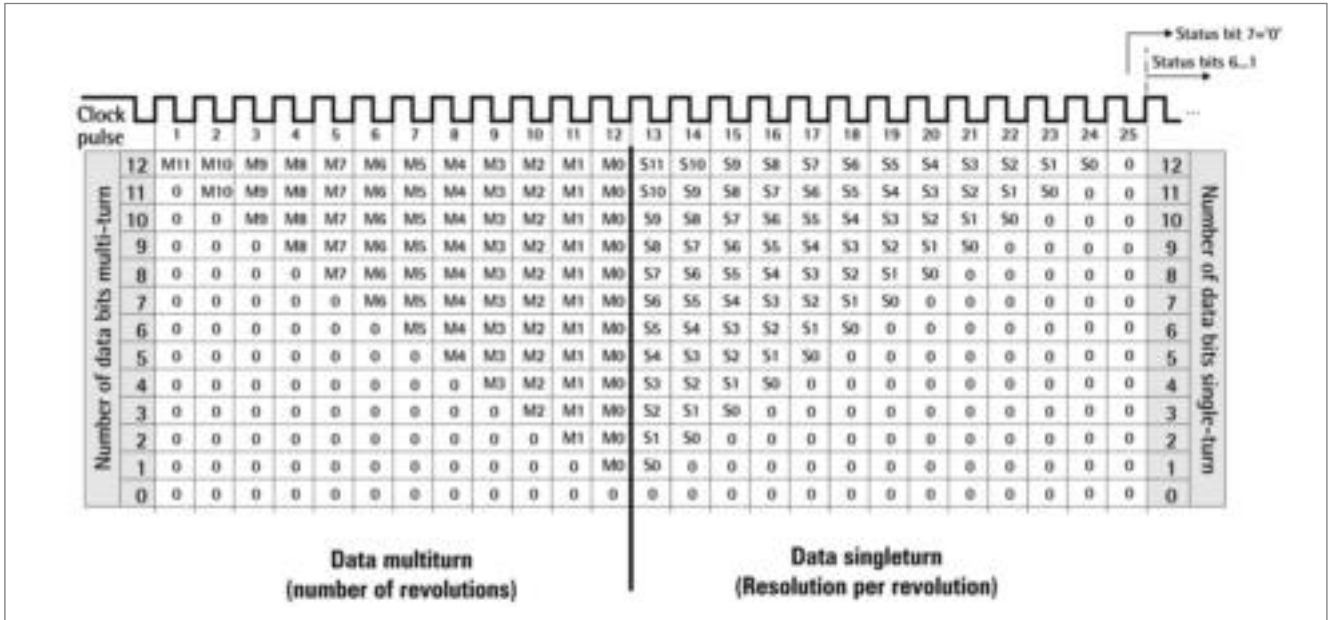

### ELECTRICAL CONNECTIONS

M23 connector (Conin), 12 pole / cable

Cable Colour	M23 (Conin) Pin	Signal
green	1	$\overline{\text{Clock}}$
yellow	2	Clock
pink	3	Data
grey	4	$\overline{\text{Data}}$
brown	5	RS 232 TxD
white	6	RS 232 RxD
black	7	0 V-signal output
blue	8	$\overline{\text{Direction}}$
red	9	Preset 1
violet	10	Preset 2
white <sup>1</sup>	11	DC 10 - 30 V
brown <sup>1</sup>	12	0 V (supply voltage)

<sup>1</sup> bigger cross section 0.5 mm <sup>2</sup>

### DIMENSIONED DRAWINGS

see chapter "Dimensioned drawings AC 58", starting page 185

ORDERING INFORMATION

Type	Resolution	Supply voltage	Flange, Protection, Shaft <sup>1,2</sup>	Interface	Connection
<input type="checkbox"/>	<input type="checkbox"/>	<input type="checkbox"/>	<input type="checkbox"/>	<input type="checkbox"/>	<input type="checkbox"/>
<b>AC58</b>	<b>0010</b> 10 Bit ST <b>0012</b> 12 Bit ST <b>0013</b> 13 Bit ST <b>0014</b> 14 Bit ST <b>0017</b> 17 Bit ST <b>1212</b> 12 Bit MT + 12 Bit ST <b>1213</b> 12 Bit MT + 13 Bit ST <b>1214</b> 12 Bit MT + 14 Bit ST <b>1217</b> 12 Bit MT + 17 Bit ST higher resolution on request	<b>E</b> DC 10 - 30 V	<b>S.41</b> <b>Synchro, IP64, 6 mm</b> <b>S.71</b> <b>Synchro, IP67, 6 mm</b> <b>K.42</b> <b>Clamping, IP64, 10 mm</b> <b>K.46</b> Clamping, IP64, 9.52 mm <b>K.72</b> <b>Clamping, IP67, 10 mm</b> <b>K.76</b> Clamping, IP67, 9.52 mm <b>F.46</b> Spring tether, IP64, hubs-haft 9.52 mm, mounting with clamping ring front <b>F.42</b> <b>Spring tether, IP64, hubs-haft 10 mm, mounting with clamping ring front</b> <b>F.47</b> <b>Spring tether, IP64, hubs-haft 12 mm, mounting with clamping ring front</b> <b>Q.46</b> Square, IP64, 9.52 mm <b>Q.42</b> Square, IP64, 10 mm <b>Q.76</b> Square, IP67, 9.52 mm <b>Q.72</b> Square, IP67, 10 mm	<b>SP</b> SSI programmable	<b>G</b> M23 connector (Conin), 12 pole, axial, ccw <b>H</b> M23 connector (Conin), 12 pole, radial, ccw

<sup>1</sup> Protection class IP67 not available in combination with preset key and LED display

<sup>2</sup> IP67 on cover with connector only if IP67 mating connector mounted properly.

Preferably available versions are printed in bold type.

ACCESSORIES

see chapter "Accessories", starting page 322

DIMENSIONED DRAWINGS

Synchro flange "S"

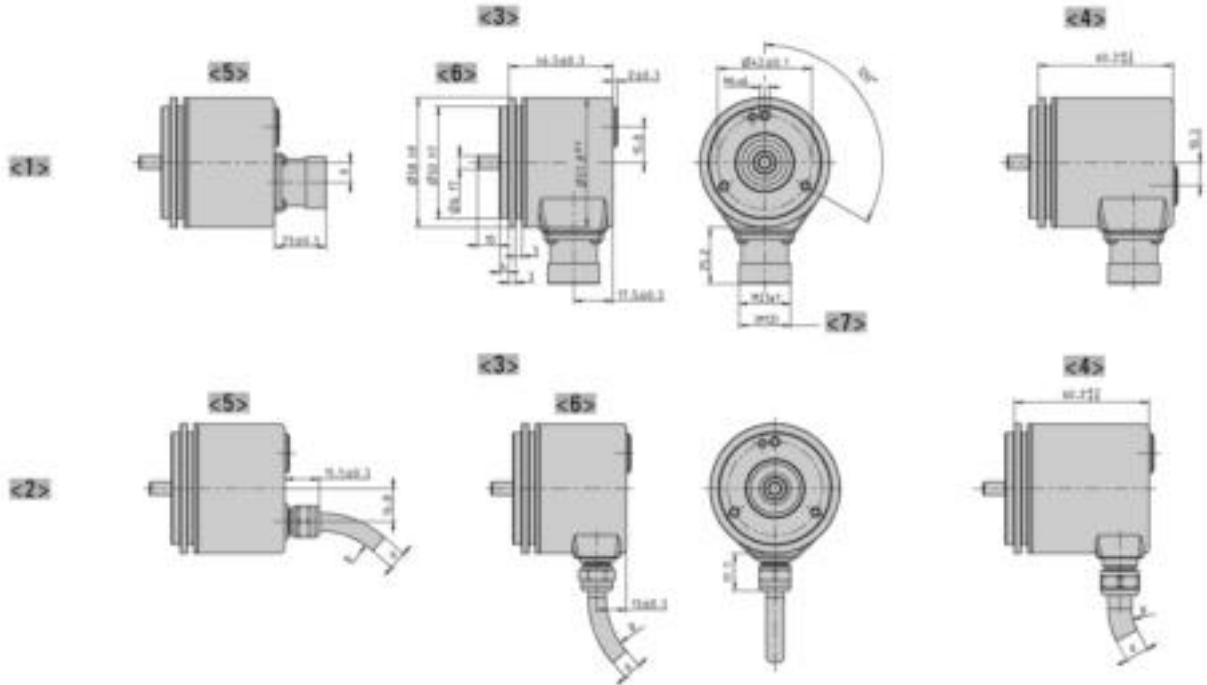

- <1> Connection M23 (Conin)
- <2> Connection cable
- <3> Interface: BiSS, SSI, ST-Parallel
- <4> Interface: MT-Parallel (only with cable), Fieldbus, SSI-P
- <5> axial
- <6> radial
- <7> Value in brackets alternative at SSI

Cable bending radius R for flexible installation  $\geq 15 \times$  cable diameter  
 Cable bending radius R for fixed installation  $\geq 7.5 \times$  cable diameter  
 Cable  $\varnothing$  d BiSS/SSI/SSI-P:  $7,1^{+1,2}$   
 Cable  $\varnothing$  d ST-P:  $7,8^{+0,9}$   
 Cable  $\varnothing$  d MT-P:  $9,3^{+1,3}$   
 Cable  $\varnothing$  d Fieldbus:  $7,1^{+1,2}$

Dimensions in mm

DIMENSIONED DRAWINGS (continued)

Clamping flange "K"

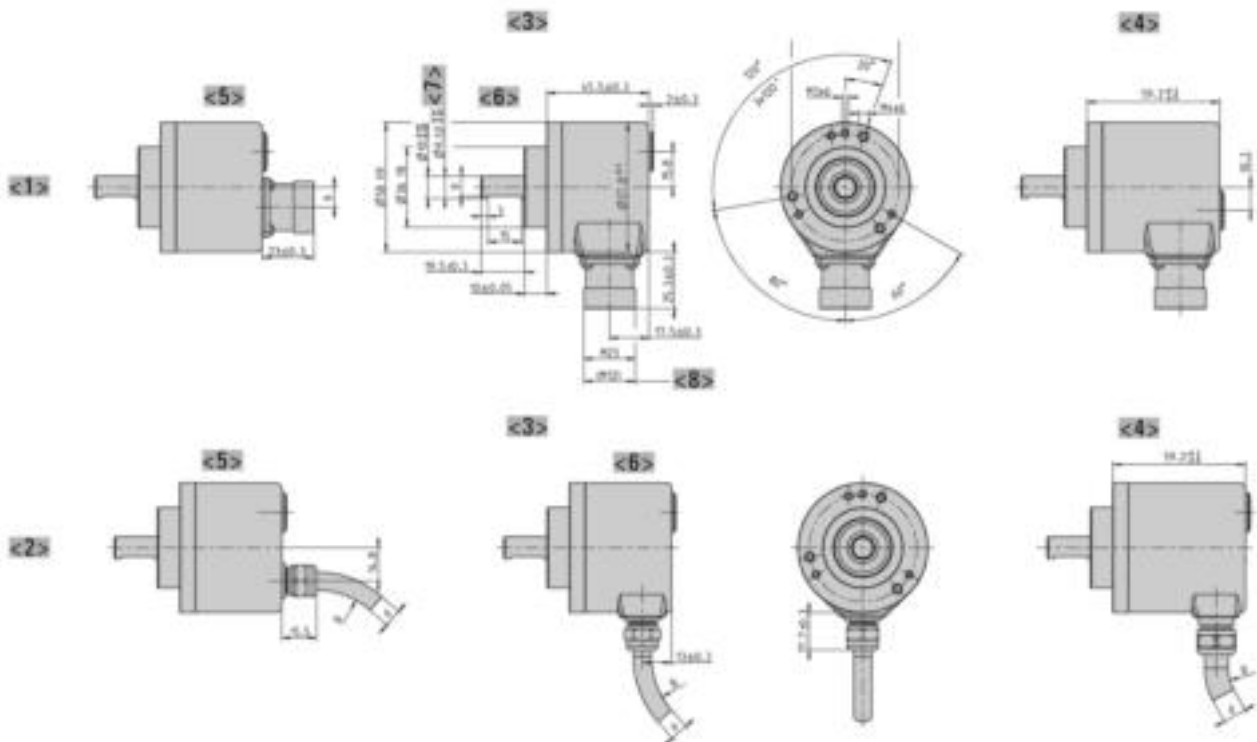

- <1> Connection M23 (Conin)
- <2> Connection cable
- <3> Interface: BiSS, SSI, ST-Parallel
- <4> Interface: MT-Parallel (only with cable), Fieldbus, SSI-P
- <5> axial
- <6> radial
- <7> alternative

- <8> Value in brackets alternative at SSI
- Cable bending radius R for flexible installation  $\geq 15 \times$  cable diameter
- Cable bending radius R for fixed installation  $\geq 7.5 \times$  cable diameter
- Cable  $\varnothing$  d BiSS/SSI/SSI-P:  $7,1^{+1,2}$
- Cable  $\varnothing$  d ST-P:  $7,8^{+0,9}$
- Cable  $\varnothing$  d MT-P:  $9,3^{+1,3}$
- Cable  $\varnothing$  d Fieldbus:  $7,1^{+1,2}$

Dimensions in mm

DIMENSIONED DRAWINGS (continued)

Hollow shaft "F"

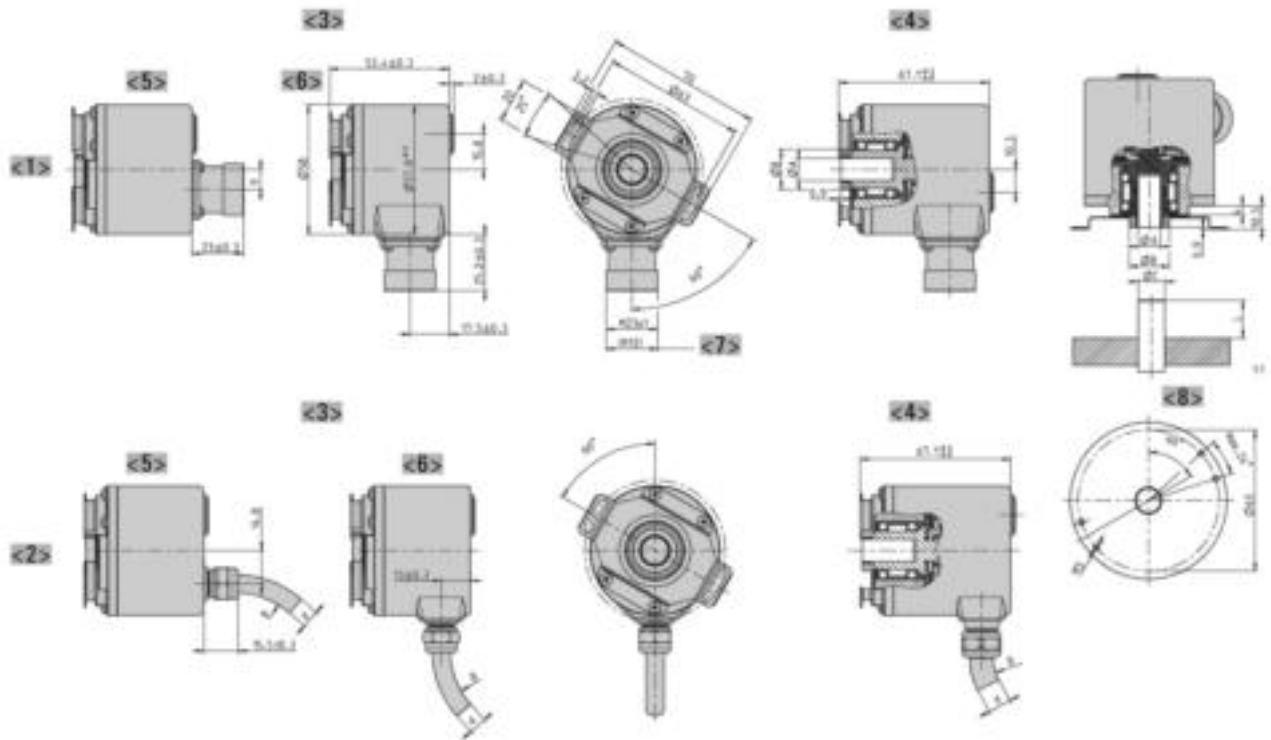

	Dim.				Unit
Hollow shaft Ø A	10 <sup>+0.012</sup>	12 <sup>+0.012</sup>	9,52 <sup>+0.012</sup>	12,7 <sup>+0.012</sup>	mm
Connecting shaft Ø C	10 <sub>g7</sub>	12 <sub>g7</sub>	9,52 <sub>g7</sub>	12,7 <sub>g7</sub>	mm
Clamping ring Ø B	18	20	18	22	mm
L <sub>min</sub>	15	18	15	18	mm
L <sub>max</sub>	20	20	20	20	mm
Shaft code	"2"	"7"	"6"	"E"	
L = Inside length of connection shaft					

- <1> Connection M23 (Conin)
  - <2> Connection cable
  - <3> Interface: BiSS, SSI, ST-Parallel
  - <4> Interface: MT-Parallel (only with cable), Fieldbus, SSI-P
  - <5> axial
  - <6> radial
  - <7> Value in brackets alternative at SSI
  - <8> Customer side
- Cable bending radius R for flexible installation ≥ 15 x cable diameter  
 Cable bending radius R for fixed installation ≥ 7.5 x cable diameter  
 Cable Ø d BiSS/SSI/SSI-P: 7,1<sup>+1,2</sup>  
 Cable Ø d ST-P: 7,8<sup>+0,9</sup>  
 Cable Ø d MT-P: 9,3<sup>+1,3</sup>  
 Cable Ø d Fieldbus: 7,1<sup>+1,2</sup>

Dimensions in mm

DIMENSIONED DRAWINGS (continued)

Square flange "Q"

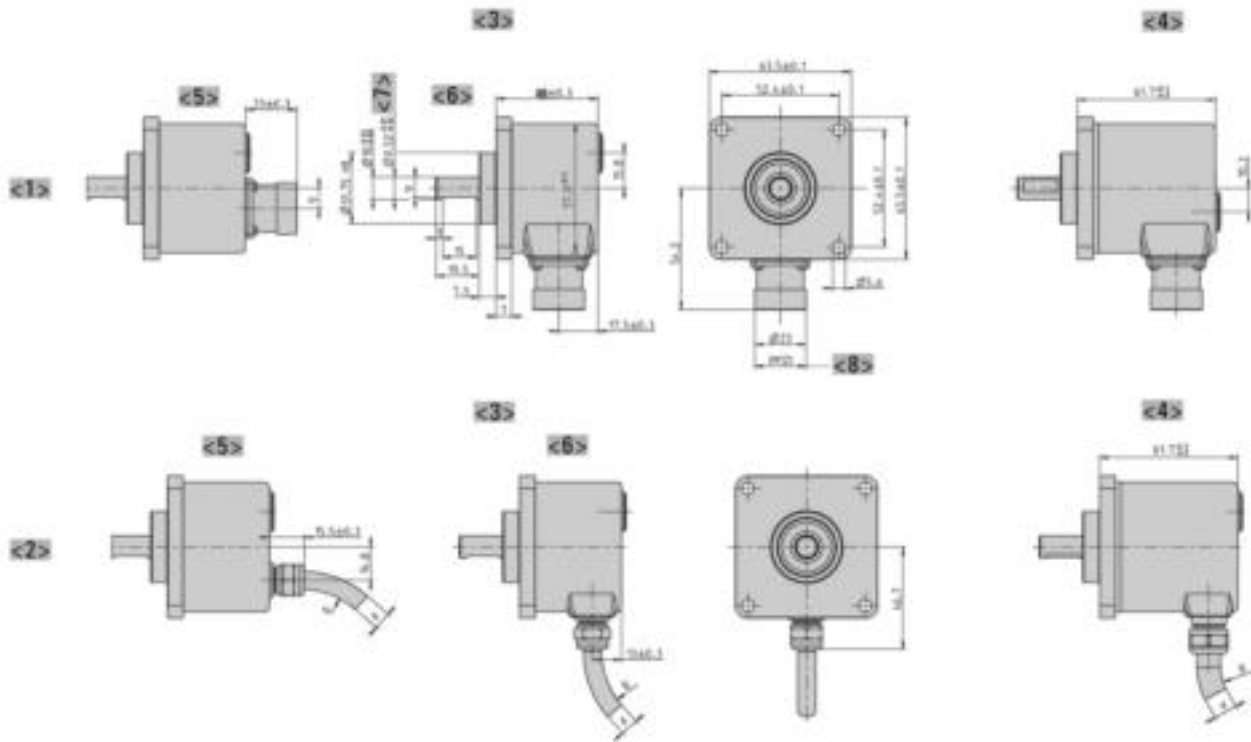

- <1> Connection M23 (Conin)
- <2> Connection cable
- <3> Interface: BiSS, SSI, ST-Parallel
- <4> Interface: MT-Parallel (only with cable), Fieldbus, SSI-P
- <5> axial
- <6> radial
- <7> alternative

- <8> Value in brackets alternative at SSI
- Cable bending radius R for flexible installation  $\geq 15 \times$  cable diameter
- Cable bending radius R for fixed installation  $\geq 7.5 \times$  cable diameter
- Cable  $\varnothing$  d BiSS/SSI/SSI-P:  $7,1^{+1,2}$
- Cable  $\varnothing$  d ST-P:  $7,8^{+0,9}$
- Cable  $\varnothing$  d MT-P:  $9,3^{+1,3}$
- Cable  $\varnothing$  d Fieldbus:  $7,1^{+1,2}$

Dimensions in mm

DIMENSIONED DRAWINGS (continued)

Bus covers

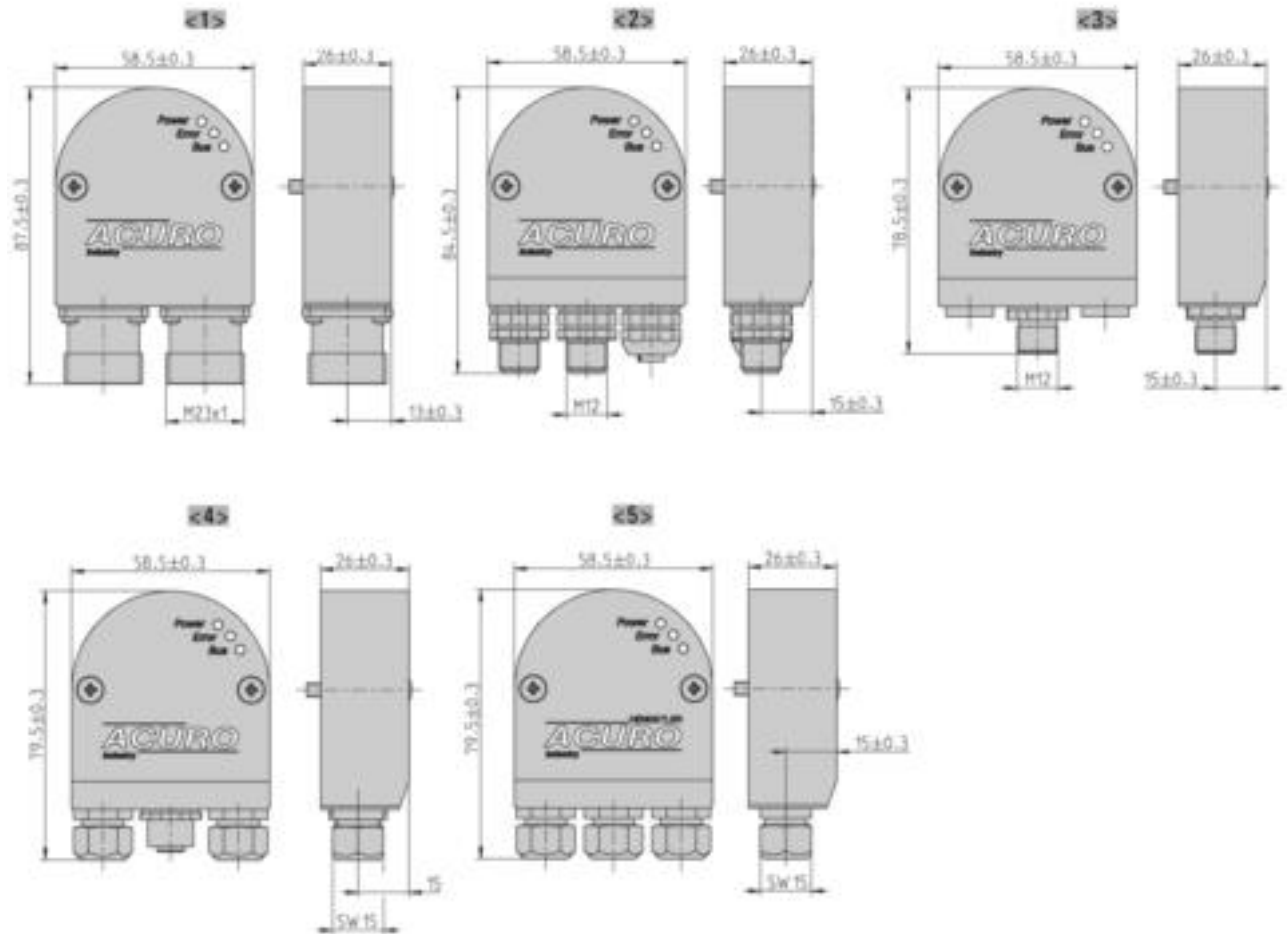

- <1> Connection "I"
- <2> Connection "R"
- <3> Connection "S"

- <4> Connection "T"
- <5> Connection "Z"

Dimensions in mm

DIMENSIONED DRAWINGS (continued)

Synchro flange "S"

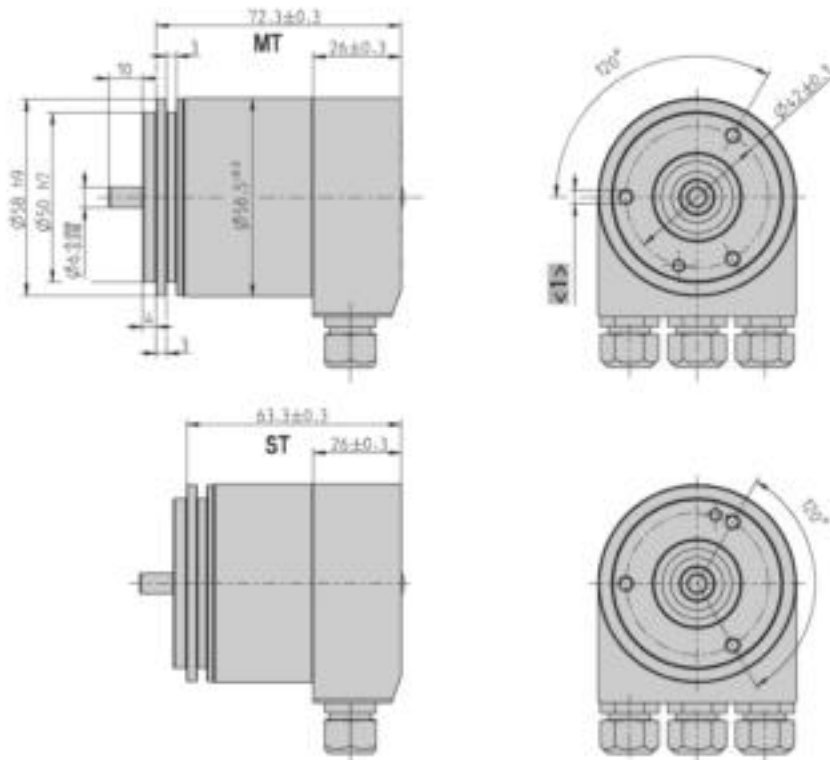

<1> 3xM4 (6 deep)

Dimensions in mm



DIMENSIONED DRAWINGS (continued)

Clamping flange "K"

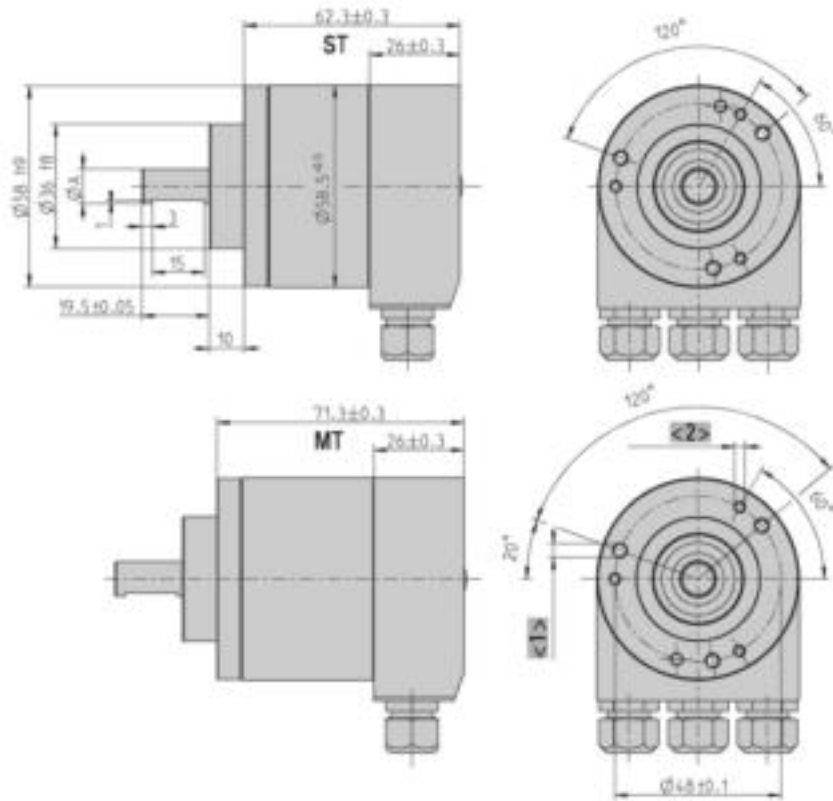

	Dim.		Unit
Shaft Ø A	10 <sup>-0.01/-0.02</sup>	9.52 <sup>-0.01/-0.02</sup>	mm
Shaft code	"2"	"6"	

- <1> 3xM4 (6 deep)
- <2> 3xM3 (6 deep)

Dimensions in mm

DIMENSIONED DRAWINGS (continued)

Hollow shaft "F"

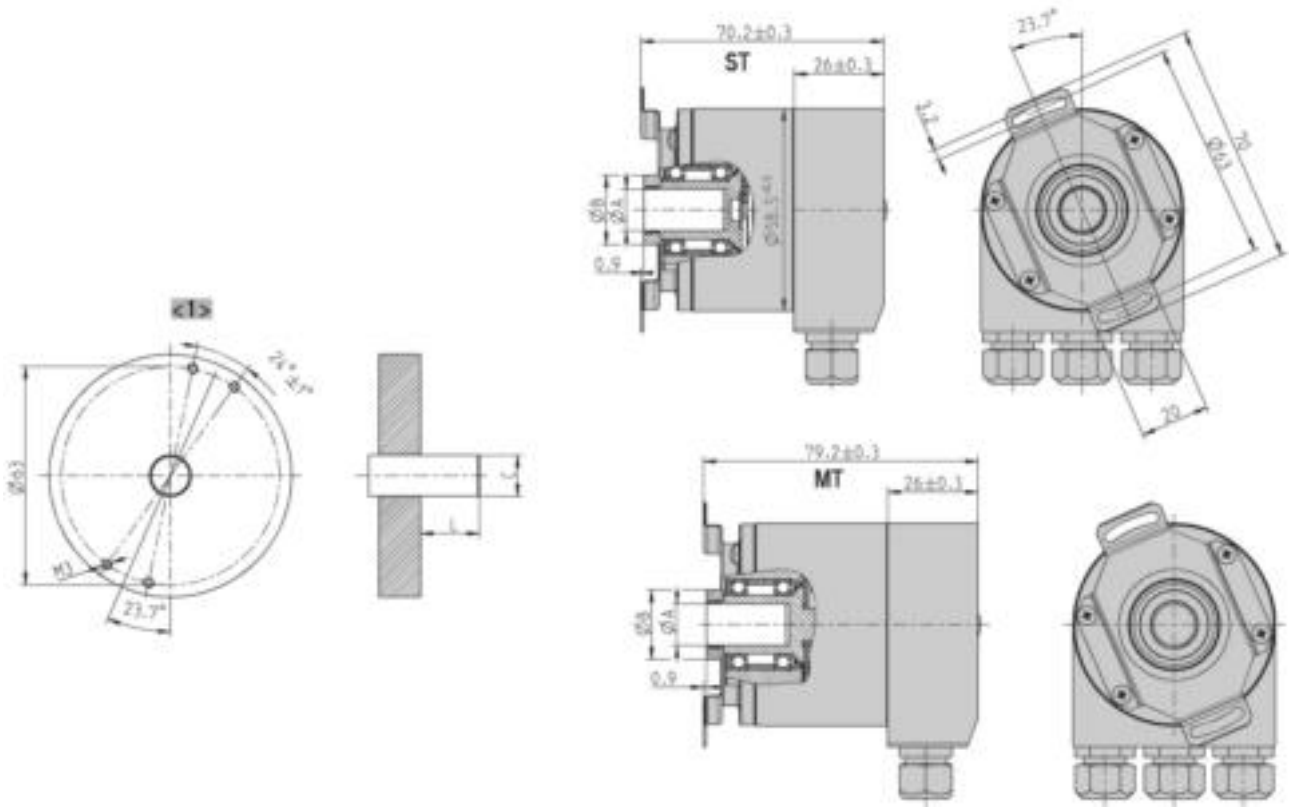

	Dim.				Unit
Hollow shaft Ø A	10 <sup>+0.012</sup>	12 <sup>+0.012</sup>	9,52 <sup>+0.012</sup>	12,7 <sup>+0.012</sup>	mm
Connecting shaft Ø C	10 <sub>g7</sub>	12 <sub>g7</sub>	9,52 <sub>g7</sub>	12,7 <sub>g7</sub>	mm
Clamping ring Ø B	18	20	18	22	mm
L <sub>min</sub>	15	18	15	18	mm
L <sub>max</sub>	20	20	20	20	mm
Shaft code	"2"	"7"	"6"	"E"	
L = Inside length of connection shaft					

<1> Customer side

Dimensions in mm

DIMENSIONED DRAWINGS (continued)

Square flange "Q"

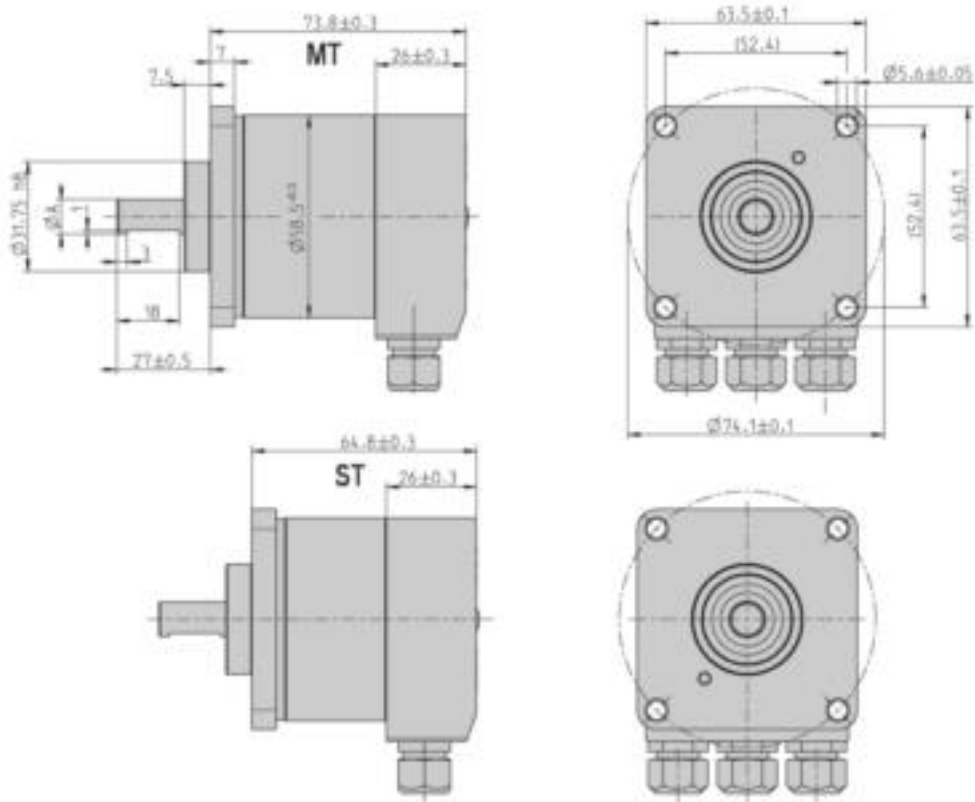

	Dim.		Unit
Shaft Ø A	10 <sup>-0.01/-0.02</sup>	9.52 <sup>-0.01/-0.02</sup>	mm
Shaft code	"2"	"6"	

Dimensions in mm

## Absolute

## BiSS / SSI



- Same electrical performance as ACURO industry
- Robust bearings for long life
- Hollow shaft up to 50 mm
- Absolute singleturn
- Revolution 11-17 Bit
- BiSS or SSI interface
- Optional: Sine-Cosine 4096 increments
- DC 5 or 10 - 30 V
- Integrated diagnostic system



### GENERAL INFORMATION

### HENGSTLER OPTOASIC Technology

The central Element of the ACURO AC110 is the latest Hengstler OptoASIC technology, which offers the following key benefits.

- Outstanding reliability by reduced number of components and integrated diagnostics systems
- Aging compensation by integrated LED light regulation
- Integrated monitoring of pollution, disk damage, LED lifetime and temperature

The ACURO AC110 is ideally suited for applications like:

- Gearless drive
- Gearless elevators
- Industrial Machinery

### TECHNICAL DATA mechanical

Housing diameter	110 mm
Shaft diameter	50 mm (Hub shaft)
Mounting of shaft	Keyway, Rear clamping ring
Protection class shaft input (EN 60529)	IP50 or IP64
Protection class housing (EN 60529)	IP40 or IP64
Axial endplay of mounting shaft (hubshaft)	± 0.5 mm
Radial runout of mating shaft (hubshaft)	± 0.05 mm
Max. speed	IP40: max. 3600 rpm IP50: max. 2000 rpm IP64: max. 1500 rpm
Torque	15 Ncm
Vibration resistance (DIN EN 60068-2-6)	100 m/s <sup>2</sup> (10 ... 500 Hz)
Shock resistance (DIN EN 60068-2-27)	1000 m/s <sup>2</sup> (6 ms)
Operating temperature	-20 °C ... +70 °C
Storage temperature	-50 °C ... +80 °C
Material shaft	Stainless Steel / Aluminum, ceramic coated
Material housing	Aluminum
Weight	approx. 1000 g

## Absolute

## BiSS / SSI

**TECHNICAL DATA**  
**mechanical (continued)**

Connection	Cable, radial Cable 1.5 m with M23 connector (Conin), 12 pole, axial or radial
------------	---

**TECHNICAL DATA**  
**electrical**

Supply voltage	-5%/ 10% DC 5 V DC 10-30 V
Max. current w/o load	120 mA (ST)
Resolution singleturn	10 - 17 Bit
Output code	Binary, Gray
Drives	Clock and Data / RS422
Incremental signals optional	Sinus-Cosinus 1 Vpp
Number of pulses	4096
3dB limiting frequency	500 kHz
Alarm output	Alarm bit (SSI Option), warning and alarm bit (BiSS)

**RECOMMENDED DATA TRANSFER RATE**  
**bei SSI**

The max. data transfer rate depends on the cable length. For Clock /  $\overline{\text{Clock}}$  and Data /  $\overline{\text{Data}}$  please use twisted pairs. Use shielded cable.

Cable length	Frequency
< 50 m	< 400 kHz
< 100 m	< 300 kHz
< 200 m	< 200 kHz
< 400 m	< 100 kHz

**ELECTRICAL CONNECTIONS**  
**Cable / Cable with M23 connector (Conin),**  
**12 pole**

Colour cable	Cable connector	Signal
brown <sup>4</sup>	1	0 V (supply voltage)
pink	2	Data
yellow	3	Clock
	4	N.C.
blue	5	$\overline{\text{Direction}}$ <sup>1</sup>
	6	N.C.
	7	N.C.
white <sup>4</sup>	8	DC 5 V <sup>3</sup> / DC 10 - 30 V
	9	N.C.
grey	10	$\overline{\text{Data}}$
green	11	$\overline{\text{Clock}}$
black	12	0 V-signal output <sup>2</sup>
Screen		Shielded with housing

<sup>1</sup> Direction: + UB or unconnected = ascending code values with rotation cw

0 V = descending code values with rotation cw

<sup>2</sup> Connected with 0 V in the encoder. Use this output to lay Direction on logical "0" if required.

<sup>3</sup> Notice: when supply voltage = DC 5V  $\Rightarrow$  max. cable length 10 m

<sup>4</sup> Use only thin wires 0.14 mm <sup>2</sup>

DIMENSIONED DRAWINGS

Keyway

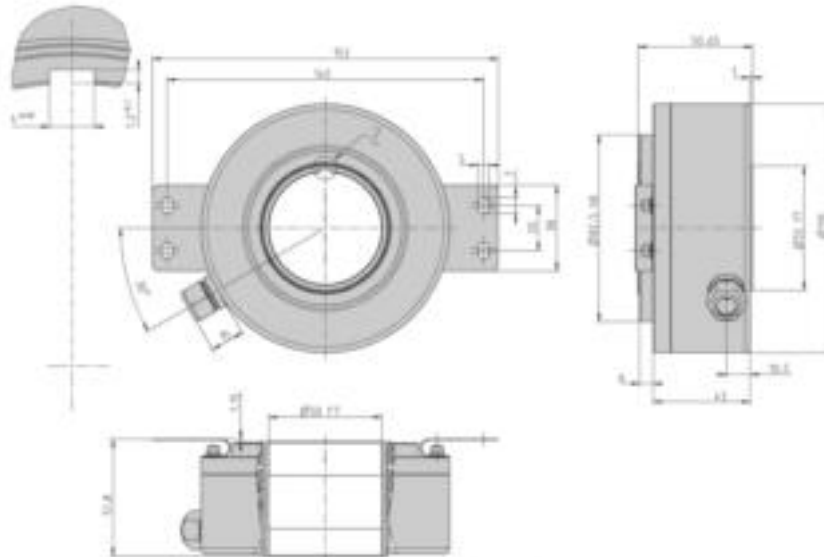

Dimensions in mm

Clamping ring

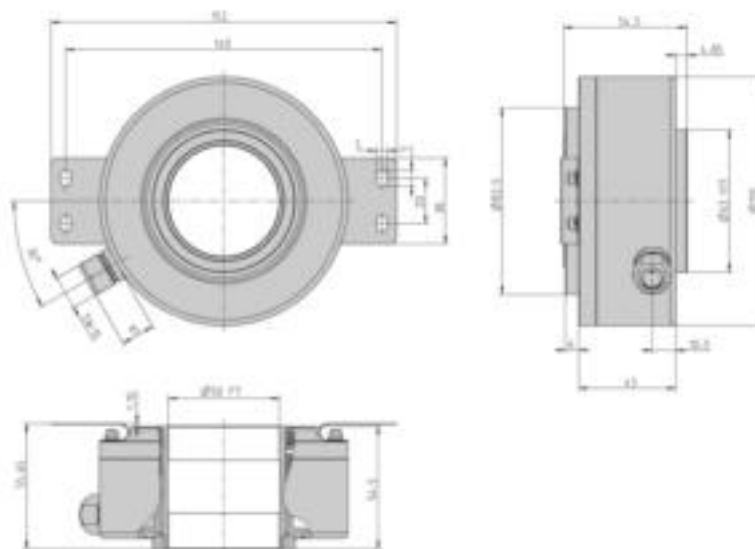

Dimensions in mm

### ORDERING INFORMATION

Type	Resolution <sup>1</sup>	Supply voltage <sup>2</sup>	Shaft	Protection	Spring tether	Interface	Connection
<input type="checkbox"/>	<input type="checkbox"/>	<input type="checkbox"/>	<input type="checkbox"/>	<input type="checkbox"/>	<input type="checkbox"/>	<input type="checkbox"/>	<input type="checkbox"/>
<b>AC110</b>	<b>0010</b> 10 Bit ST <b>0012</b> 12 Bit ST <b>0013</b> 13 Bit ST <b>0014</b> 14 Bit ST <b>0017</b> 17 Bit ST	<b>A</b> DC 5 V <b>E</b> DC 10 - 30 V	<b>K50</b> Keyway (4x1,2) / 50 mm <b>H50</b> Clamping ring / 50 mm	<b>0</b> IP40 <b>1</b> IP50 <b>4</b> IP64	<b>0</b> Without tether <b>B</b> With tether	<b>BI</b> BiSS <b>SB</b> SSI binary <b>SG</b> SSI Gray	<b>B</b> Cable, radial <b>B-D</b> 1.5 m cable with M23 connector (Conin), 12 pole

<sup>1</sup> When resolution > 14 Bit: max. clock frequency 178 kHz

<sup>2</sup> Max. cable length for DC 5 V: 10 m

### ORDERING INFORMATION

#### Selection of cable length

Versions with cable outlet (connection A, B, E or F) are available with various lengths of cable. To order your desired cable length, please add the respective code to the end of your ordering code. Further cable lengths on request.

Code	Cable length
without code	1.5 m
-D0	3 m
-F0	5 m
-K0	10 m
-P0	15 m
-U0	20 m
-V0	25 m

### ACCESSORIES

see chapter "Accessories", starting page 322

## Stainless Industrial Types

The absolute encoder line ACURO® and incremental encoder line "RI" are available as stainless steel encoders under AC59 or AC61 for absolute encoders and RI59 for incremental encoder.

The absolute stainless steel encoders are available in the versions AC59 and AC61:

- AC59: drawn stainless steel housing, together with cable outlet, no access to control elements
- AC61: machined housing, possible with cable or bus cover, access to control elements (DIP switch, reset switch)

Available interfaces: SSI, BiSS, SSI-P, Parallel, Profibus, CAN layer2, CANopen, DeviceNet, Interbus

The incremental stainless steel encoder is available in the version RI59:

- RI59: drawn stainless steel housing with cable outlet

### Examples of applications for stainless steel encoders:

- oil field applications
- packaging machines
- food & beverage
- ship equipment
- other offshore applications



## Incremental



- Stainless steel encoder with high protection class
- High corrosion resistance
- Use in the area of food production
- Applications: packing machines, bottling machines, washing plants, mixers, cranes, hoists, marine outfitters



### NUMBER OF PULSES

1 / 2 / 3 / 4 / 5 / 10 / 15 / 20 / 25 / 30 / 35 / 40 / 45 / 50 / 60 / 64 / 70 / 72 / 80 / **100** / 125 / 128 / 144 / 150 / 180 / 200 / 230 / **250** / 256 / 300 / 314 / 350 / 360 / 375 / 400 / 460 / 480 / **500** / 512 / 600 / 625 / 635 / 720 / 900 / **1000** / **1024** / 1200 / **1250** / 1500 / 1600 / 1800 / 2000 / 2048 / **2500** / 3000 / 3480 / **3600** / 3750 / 3968 / 4000 / **4096** / 4800 / **5000** / 5400 / 6000 / 7200 / 7680 / 8000 / 8192 / 9000 / 10000

Other number of pulses on request

Preferably available versions are printed in bold type.

### TECHNICAL DATA mechanical

Housing diameter	58 mm
Shaft diameter	9.52 mm / 10 mm (Solid shaft)
Flange (Mounting of housing)	Square flange 63.5 mm
Protection class shaft input (EN 60529)	IP67
Protection class housing (EN 60529)	IP67
Shaft load axial / radial	40 N / 60 N
Max. speed	max. 10 000 rpm
Torque	≤ 1 Ncm
Moment of inertia	approx. 20 gcm <sup>2</sup>
Vibration resistance (DIN EN 60068-2-6)	100 m/s <sup>2</sup> (10 ... 2000 Hz)
Shock resistance (DIN EN 60068-2-27)	1000 m/s <sup>2</sup> (6 ms)
Operating temperature	-10 °C ... +70 °C
Storage temperature	-25 °C ... +85 °C
Material housing	Stainless Steel
Weight	approx. 620 g
Connection	Cable, axial or radial

### TECHNICAL DATA electrical

General design	as per DIN VDE 0160, protection class III, contamination level 2, overvoltage class II
Supply voltage <sup>1</sup>	RS422 + Sense (T): DC 5 V ±10 % RS422 + Alarm (R): ± 10% DC 5 V or DC 10 - 30 V Push-pull (K), Push-pull antivalent (I): DC 10-30 V
Max. current w/o load	40 mA (DC 5 V), 60 mA (DC 10 V), 30 mA (DC 24 V)
Max. pulse frequency	RS422: 300 kHz Push-pull: 200 kHz
Standard output versions <sup>2</sup>	RS422 + Alarm (R): A, B, N, $\bar{A}$ , $\bar{B}$ , $\bar{N}$ , $\overline{Alarm}$ RS422 + Sense (T): A, B, N, $\bar{A}$ , $\bar{B}$ , $\bar{N}$ , Sense Push-pull (K): A, B, N, $\overline{Alarm}$ Push-pull complementary (I): A, B, N, $\bar{A}$ , $\bar{B}$ , $\bar{N}$ , $\overline{Alarm}$

## Incremental

### TECHNICAL DATA electrical (continued)

Pulse width error	± max. 25° electrical
Number of pulses	1 ... 10 000
Alarm output	NPN-O.C., max. 5 mA
Pulse shape	Square wave
Pulse duty factor	1:1

<sup>1</sup> Pole protection with supply voltage DC 10 - 30 V

<sup>2</sup> Output description and technical data see chapter "Technical basics"

### ELECTRICAL CONNECTIONS Cable PVC

Connecting cable Colour	Lead Ø	Output RS422 T and R	push-pull K and I
red	0.5 mm <sup>2</sup>	DC 5/10 - 30 V	DC 10 - 30 V
red/yellow	0.14 mm <sup>2</sup>	Sense V <sub>CC</sub>	Sense V <sub>CC</sub>
white	0.14 mm <sup>2</sup>	Channel A	Channel A
white/brown	0.14 mm <sup>2</sup>	Channel $\bar{A}$	Channel $\bar{A}$ <sup>1</sup>
green	0.14 mm <sup>2</sup>	Channel B	Channel B
green/brown	0.14 mm <sup>2</sup>	Channel $\bar{B}$	Channel $\bar{B}$ <sup>1</sup>
yellow	0.14 mm <sup>2</sup>	Channel N	Channel N
yellow/brown	0.14 mm <sup>2</sup>	Channel $\bar{N}$	Channel $\bar{N}$ <sup>1</sup>
black	0.5 mm <sup>2</sup>	GND	GND
black/yellow	0.14 mm <sup>2</sup>	$\bar{A}$ larm/Sense GND <sup>2</sup>	$\bar{A}$ larm
screen <sup>3</sup>		screen <sup>3</sup>	screen <sup>3</sup>

<sup>1</sup> only push-pull complementary (I)

<sup>2</sup> depending on ordering code

<sup>3</sup> connected with encoder housing

### DIMENSIONED DRAWINGS

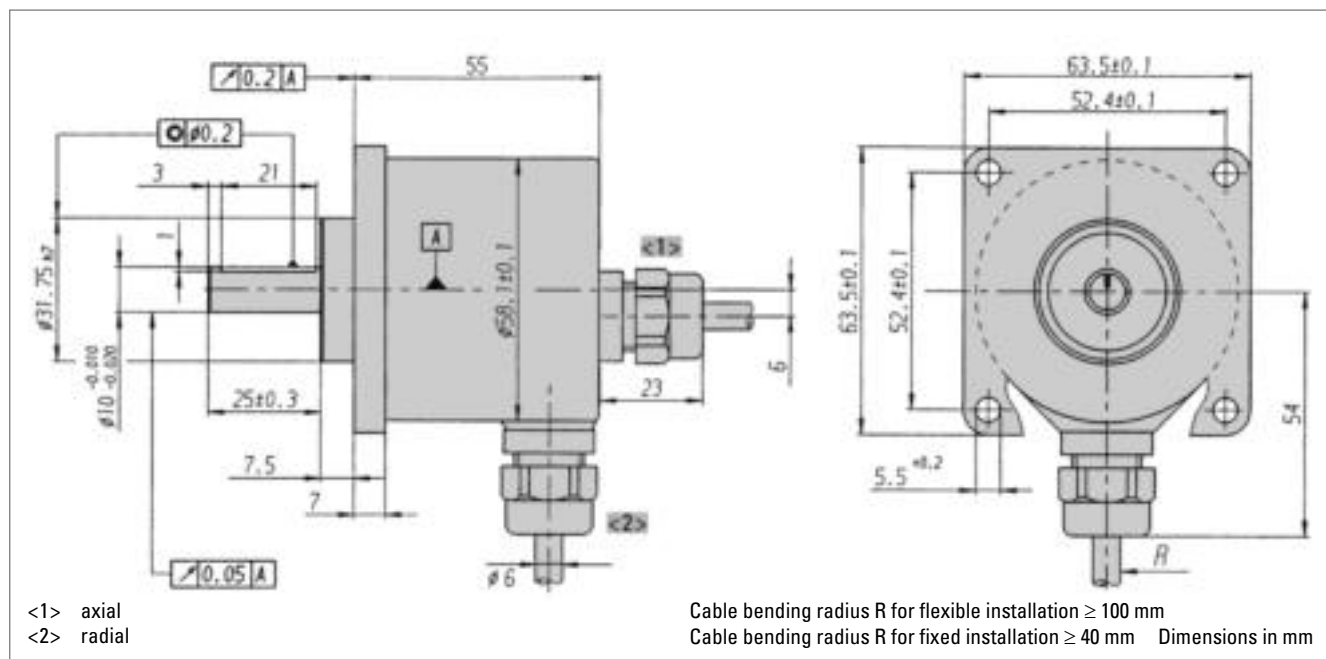

## Incremental

### ORDERING INFORMATION

Type	Number of pulses	Supply voltage	Flange, Protection, Shaft	Output <sup>1</sup>	Connection
<input type="checkbox"/>	<input type="checkbox"/>	<input type="checkbox"/>	<input type="checkbox"/>	<input type="checkbox"/>	<input type="checkbox"/>
<b>RI59-0</b>	<b>1 ... 10000</b>	<b>A</b> DC 5 V <b>E</b> DC 10 - 30 V	<b>Q.76</b> Square, IP67, 9.52 mm <b>Q.72</b> Square, IP67, 10 mm <b>Q.7B</b> Square 63.5x63.5, IP67, 9.52 x 25 mm <b>Q.7A</b> Square 63.5x63.5, IP67, 10 x 25 mm	<b>R</b> RS422 +Alarm <b>T</b> RS422 +Sense <b>K</b> Push-pull <b>I</b> Push-pull complementary	<b>A</b> PVC cable, axial <b>B</b> PVC cable, radial

<sup>1</sup> Output code "K" and "I": short-circuit-proof

### ORDERING INFORMATION

#### Selection of cable length

Versions with cable outlet (connection A, B, E or F) are available with various lengths of cable. To order your desired cable length, please add the respective code to the end of your ordering code. Further cable lengths on request.

Code	Cable length
without code	1.5 m
-D0	3 m
-F0	5 m
-K0	10 m
-P0	15 m
-U0	20 m
-V0	25 m

### ACCESSORIES

see chapter "Accessories", starting page 322

## Absolute

## BiSS / SSI



Version AC 59 with cable outlet

- Compact design
- Protection class IP67
- High corrosion resistance
- Robust design
- Resolution up to 29 Bit (17 Bit ST, 12 Bit MT)
- Versions with cable
- Applications: packaging machine for food and beverage, ship equipment (e.g. cranes, winches, cable laying ships), offshore applications



### GENERAL INFORMATION

The absolute stainless steel encoders are available in the Versions AC 59 and AC 61

- AC 59: drawn stainless steel housing, only together with cable outlet, no access to control elements
- AC 61: machined housing, possible with cable or bus cover, access to control elements (DIP switch, Reset switch)

### TECHNICAL DATA mechanical

Housing diameter	58 mm
Shaft diameter	9.52 mm / 10 mm (Solid shaft)
Flange (Mounting of housing)	Square flange 63.5 mm
Protection class shaft input (EN 60529)	IP67
Protection class housing (EN 60529)	IP67
Shaft load axial / radial	40 N / 60 N
Max. speed	max. 6000 rpm (continuous), max. 10 000 rpm (short term)
Torque	≤ 1 Ncm
Moment of inertia	approx. 20 gcm <sup>2</sup>
Vibration resistance (DIN EN 60068-2-6)	100 m/s <sup>2</sup> (10 ... 500 Hz)
Shock resistance (DIN EN 60068-2-27)	1000 m/s <sup>2</sup> (6 ms)
Operating temperature	-40 °C ... +100 °C
Storage temperature	-40 °C ... +85 °C
Material shaft	Stainless Steel
Material housing	Stainless Steel
Weight	approx. 700 g with 1.5 m cable
Connection	Cable, axial or radial

### TECHNICAL DATA electrical

Supply voltage	± 10% DC 5 V or DC 10 - 30 V
Max. current w/o load	50 mA (ST), 100 mA (MT)
Resolution singleturn	10 - 17 Bit Gray Excess: 360, 720 increments
Resolution multiturn	12 Bit
Output code	Binary, Gray
Drives	Clock and Data / RS422

## Absolute

## BiSS / SSI

### TECHNICAL DATA electrical (continued)

Linearity	± ½ LSB (± 1 LSB for resolution > 13 Bit)
Incremental signals optional	Sinus-Cosinus 1 Vpp
Number of pulses	2048
3dB limiting frequency	500 kHz
Absolute accuracy	±35"
Repeatability	±7"
Parametrization	Code type, Direction, Warning, Alarm
Control inputs	Direction
Reset key	Disable via parameterization
Alarm output	Alarm bit (SSI Option), warning and alarm bit (BiSS)
Status LED	Green = ok, red = alarm

### RECOMMENDED DATA TRANSFER RATE bei SSI

The max. data transfer rate depends on the cable length. For Clock /  $\overline{\text{Clock}}$  and Data /  $\overline{\text{Data}}$  please use twisted pairs. Use shielded cable.

Cable length	Frequency
< 50 m	< 400 kHz
< 100 m	< 300 kHz
< 200 m	< 200 kHz
< 400 m	< 100 kHz

### DATA FORMAT Singleturn

Resolution	Data Bits											
		T1 ... T9	T10	T11	T12	T13	T14	T15	T16	T17	T18	T19
9 Bit <sup>1</sup>	S8 ... S0	0	0	0	0	0	W <sup>2</sup>					
10 Bit <sup>1</sup>	S9 ... S1	S0	0	0	0	0	W <sup>2</sup>					
11 Bit <sup>1</sup>	S10 ... S2	S1	S0	0	0	0	W <sup>2</sup>					
12 Bit <sup>1</sup>	S11 ... S3	S2	S1	S0	0	0	W <sup>2</sup>					
13 Bit <sup>1</sup>	S12 ... S4	S3	S2	S1	S0	0	W <sup>2</sup>					
14 Bit <sup>1</sup>	S13 ... S5	S4	S3	S2	S1	S0	0	W <sup>2</sup>				
15 Bit <sup>1</sup>	S14 ... S6	S5	S4	S3	S2	S1	S0	0	W <sup>2</sup>			
16 Bit <sup>1</sup>	S15 ... S7	S6	S5	S4	S3	S2	S1	S0	0	W <sup>2</sup>		
17 Bit <sup>1</sup>	S16 ... S8	S7	S6	S5	S4	S3	S2	S1	S0	0	W <sup>2</sup>	

Examples for data format 9 Bit and 13 Bit with the optional bits alarm und parity

Resolution	Data Bits											
		T1 ... T9	T10	T11	T12	T13	T14	T15	T16	T17	T18	T19
9 Bit + P <sup>3</sup>	S8 ... S0	0	0	0	P	0	W <sup>2</sup>					
9 Bit + A <sup>4</sup>	S8 ... S0	0	0	0	A	0	W <sup>2</sup>					
9 Bit + P <sup>3</sup> + A <sup>4</sup>	S8 ... S0	0	0	0	A	P	0	W <sup>2</sup>				
9 Bit + P <sup>3</sup>	S12 ... S4	S3	S2	S1	S0	P	0	W <sup>2</sup>				
9 Bit + A <sup>4</sup>	S12 ... S4	S3	S2	S1	S0	A	0	W <sup>2</sup>				
9 Bit + P <sup>3</sup> + A <sup>4</sup>	S12 ... S4	S3	S2	S1	S0	A	P	0	W <sup>2</sup>			

## Absolute

## BiSS / SSI

### DATA FORMAT Multiturn

Resolution	Data bits									
	T1 ... T12	T13 ... T21	T22	T23	T24	T25				
24 Bit <sup>1</sup>	M11 ... M0	S11 ... S2	S1	S0	0	W <sup>2</sup>				
25 Bit <sup>1</sup>	M11 ... M0	S12 ... S3	S2	S1	S0	0	W <sup>2</sup>			
26 Bit <sup>1</sup>	M11 ... M0	S13 ... S4	S3	S2	S1	S0	0	W <sup>2</sup>		

Example for data format 24 Bit with the optional bits alarm und parity

24 Bit + P <sup>3</sup>	M11 ... M0	S11 ... S2	S1	S0	P	0	W <sup>2</sup>		
24 Bit + A <sup>4</sup>	M11 ... M0	S11 ... S2	S1	S0	A	0	W <sup>2</sup>		
24 Bit + P <sup>3</sup> + A <sup>4</sup>	M11 ... M0	S11 ... S2	S1	S0	A	P	0	W <sup>2</sup>	

S0 ... S16 Data bits for resolution per revolution

M0 ... M11 Data bits for number of revolutions (only for multiturn)

<sup>1</sup> Options (Parity bit, alarm and parity bit, zero bit) on request

<sup>2</sup>W: from this data bit on the data iteration for multiplex starts

<sup>3</sup> Parity bit: Even Parity (The parity bit expands the data bits to an even number of 1-bits).  
(Option)

<sup>4</sup> Alarm bit: is set to "1" when over temperature, under temperature, disc breakage and defect LED

### SYNCHRONOUS-SERIAL TRANSFER (SSI)

Synchronous readout of the encoder data is according to the clock rate given by the SSI-counterpart.

The number of clock rates is determined by the type of encoder (singleturn resp. multiturn) and the configuration of the special Bits as defined.

For multiple transactions (the stored value is readout several times successively) a fixed clock rate per transaction must be kept (for singleturn 13 resp. 14 clocks, for multiturn 25 resp. 26 clocks).

- In the rest position, when the last clock brush has passed by more than 30µs, the data output is logically at "1".
- With the first descending clock edge the encoder data and the special bits are

loaded in the shift register of the encoder interface.

- With each ascending clock edge the data bits are serially readout, beginning with the MSB.
- At the end of the data transfer the data output is set to logically "0" for approx. 20µs. If within these 20µs a further clock brush reaches the encoder interface, the already transferred data is readout once again. This multiple transfer of the same data makes it possible to recognize transfer errors.
- After the 20µs the data output goes to its rest position, logically "1". Subsequently new encoder data can be readout.

## Absolute

## BiSS / SSI

### ELECTRICAL CONNECTIONS

12 pole / cable  
Interface SC, BC

Cable	Signal
brown <sup>2</sup>	0 V (supply voltage)
pink	Data
yellow	Clock
white/green	A+
blue	$\overline{\text{Direction}}$ <sup>1</sup>
red/blue	B+
brown/green	A-
white <sup>2</sup>	DC 5/10 - 30 V
grey/pink	B-
grey	$\overline{\text{Data}}$
green	$\overline{\text{Clock}}$
black	Sense

<sup>1</sup>  $\overline{\text{Direction}}$  : +UB or unconnected = ascending code values with rotation cw  
0 V = descending code values with rotation cw

<sup>2</sup> use only the thin wires ( $\varnothing = 0,14$  mm)

### DIMENSIONED DRAWINGS

see chapter "Dimensioned drawings AC 59 / AC 61", starting page 232

### ORDERING INFORMATION

Type	Resolution <sup>1,2</sup>	Supply voltage	Flange, Protection, Shaft	Interface	Connection
<input type="checkbox"/>	<input type="text"/>	<input type="checkbox"/>	<input type="checkbox"/>	<input type="checkbox"/>	<input type="checkbox"/>
<b>AC59</b>	<b>0010</b> 10 Bit ST <b>0012</b> 12 Bit ST <b>0013</b> 13 Bit ST <b>0014</b> 14 Bit ST <b>0017</b> 17 Bit ST <b>0360</b> 360 increments ST <b>0720</b> 720 increments ST <b>1212</b> 12 Bit MT + 12 Bit ST <b>1213</b> 12 Bit MT + 13 Bit ST <b>1214</b> 12 Bit MT + 14 Bit ST (BiSS) <b>1217</b> 12 Bit MT + 17 Bit ST (BiSS)	<b>A</b> DC 5 V <b>E</b> DC 10 - 30 V	<b>0.76</b> Square, IP67, 9.52 mm <b>0.72</b> Square, IP67, 10 mm	<b>BI</b> BiSS <b>BC</b> BiSS (+SinCos 1Vpp) <b>SB</b> SSI binary <b>SG</b> SSI Gray <b>SC</b> SSI Gray (+SinCos 1Vpp)	<b>A</b> Cable, axial <b>B</b> Cable, radial

<sup>1</sup> Resolution 360 increments ST with Offset 76 (value range 76...435)

<sup>2</sup> Resolution 720 increments ST with Offset 152 (value range 152...871)

**Absolute****BiSS / SSI****ORDERING INFORMATION****Selection of cable length**

Versions with cable outlet (connection A, B, E or F) are available with various lengths of cable. To order your desired cable length, please add the respective code to the end of your ordering code. Further cable lengths on request.

<b>Code</b>	<b>Cable length</b>
without code	1.5 m
-D0	3 m
-F0	5 m
-K0	10 m
-P0	15 m
-U0	20 m
-V0	25 m

**ACCESSORIES**

see chapter "Accessories", starting page 322



## Absolute

## Parallel



Version AC 59 with cable outlet



Version AC 61 with bus cover

- Compact design
- Protection class IP67
- High corrosion resistance
- Robust design
- Resolution up to 26 Bit (14 Bit ST, 12 Bit MT)
- Gray or Binary code
- Encoder monitoring
- Output Tristate short circuit-proof
- Applications: packaging machine for food and beverage, ship equipment (e.g. cranes, winches, cable laying ships), offshore applications



### GENERAL INFORMATION

The absolute stainless steel encoders with parallel interface are available in the Versions AC 59 and AC 61.

- AC 59: drawn stainless steel housing, only together with Singleturn
- AC 61: machined housing

### TECHNICAL DATA mechanical

Housing diameter	AC 59: 58 mm AC 61: 61.5 mm
Shaft diameter	9.52 mm / 10 mm (Solid shaft)
Flange (Mounting of housing)	Square flange 63.5 mm
Protection class shaft input (EN 60529)	IP67
Protection class housing (EN 60529)	IP67
Shaft load axial / radial	40 N / 60 N
Max. speed	max. 6000 rpm (continuous), max. 10 000 rpm (short term)
Torque	≤ 1 Ncm
Moment of inertia	approx. 20 gcm <sup>2</sup>
Vibration resistance (DIN EN 60068-2-6)	100 m/s <sup>2</sup> (10 ... 500 Hz)
Shock resistance (DIN EN 60068-2-27)	1000 m/s <sup>2</sup> (6 ms)
Operating temperature	-40 °C ... +100 °C
Storage temperature	-40 °C ... +85 °C
Material shaft	Stainless Steel
Material housing	Stainless Steel
Weight	AC 59: approx. 700 g with 1.5 m cable AC 61: approx. 980 g with 1.5 m cable
Connection	Cable, axial or radial

## Absolute

## Parallel

### TECHNICAL DATA electrical

Supply voltage	DC 10-30 V On request: DC 5 V
Max. current w/o load	200 mA (ST), 300 mA (MT)
Resolution singleturn	10 - 14 Bit Gray Excess: 360, 720 increments
Resolution multiturn	12 Bit
Output code	Binary, Gray, Gray Excess
Linearity	$\pm \frac{1}{2}$ LSB
Output current	30 mA per Bit, short-circuit-proof
Control inputs	$\overline{\text{Latch}}$ , $\overline{\text{Direction}}$ , $\overline{\text{Tristate}}$ with ST, $\overline{\text{Tristate}}$ with MT
Alarm output	NPN-O.C., max. 5 mA
Status LED	Green = ok, red = alarm

Note: preset key only with MT (IP64), preset value = 0

### Data output level

Supply voltage $U_B$	DC 5 V - 5 % +10 % <sup>1</sup>	DC 10 - 30 V
Output level High	$\geq 3.5$ V (30 mA) $\geq 3.9$ V (10 mA)	$\geq U_B - 2.2$ V (30 mA) $\geq U_B - 1.8$ V (10 mA)
Output level Low	$\leq 1.6$ V (30 mA) $\leq 1.2$ V (10 mA)	$\leq 1.6$ V (30 mA) $\leq 1.2$ V (10 mA)
Rise time (1.5 m Cable)	$\leq 0.1$ $\mu$ s	$\leq 0.2$ $\mu$ s
Drop time (1.5 m Cable)	$\leq 0.05$ $\mu$ s	$\leq 0.1$ $\mu$ s

<sup>1</sup> on request

### Control inputs

Input	Level logical (physical)	Function
$\overline{\text{Direction}}$	1 (+ $U_B$ or open) 0 (0 V)	ascending code values when turning clockwise (cw) descending code values when turning clockwise (cw)
$\overline{\text{Latch}}$	1 (+ $U_B$ or open) 0 (0 V)	encoder data continuously changing at output encoder data stored and constant at output
$\overline{\text{Tristate}}$ (with singleturn)	1 (+ $U_B$ or open) 0 (0 V)	outputs active outputs at high impedance (Tristate mode)
$\overline{\text{Tristate}}$ (with multiturn)	1 (+ $U_B$ ) 0 (0 V or open)	outputs at high impedance (Tristate mode) outputs active

Typical actuating delay time 10  $\mu$ s with push-pull selection; when selected via O.C., an external pull-down resistor (1 K $\Omega$ ) is required

## Absolute

## Parallel

## ELECTRICAL CONNECTIONS

## Singleturn, cable

Colour (PVC)	9 Bit / 360 incr.	10 Bit / 720 incr.	12 Bit	13 Bit	14 Bit
grey/pink	N.C.	N.C.	N.C.	N.C.	S0 (LSB)
brown/yellow	N.C.	N.C.	N.C.	S0 (LSB)	S1
brown/grey	N.C.	N.C.	S0 (LSB)	S1	S2
red/blue	N.C.	N.C.	S1	S2	S3
violet	N.C.	S0 (LSB)	S2	S3	S4
white/brown	S0 (LSB)	S1	S3	S4	S5
white/green	S1	S2	S4	S5	S6
white/yellow	S2	S3	S5	S6	S7
white/grey	S3	S4	S6	S7	S8
white/pink	S4	S5	S7	S8	S9
white/blue	S5	S6	S8	S9	S10
white/red	S6	S7	S9	S10	S11
white/black	S7	S8	S10	S11	S12
brown/green	S8 (MSB)	S9 (MSB)	S11 (MSB)	S12 (MSB)	S13 (MSB)
yellow	$\overline{\text{Tristate S0...S8}}$	$\overline{\text{Tristate S0...S9}}$	$\overline{\text{Tristate S0...S11}}$	$\overline{\text{Tristate S0...S12}}$	$\overline{\text{Tristate S0...S13}}$
pink	$\overline{\text{Latch}}$	$\overline{\text{Latch}}$	$\overline{\text{Latch}}$	$\overline{\text{Latch}}$	$\overline{\text{Latch}}$
green	$\overline{\text{Direction}}$	$\overline{\text{Direction}}$	$\overline{\text{Direction}}$	$\overline{\text{Direction}}$	$\overline{\text{Direction}}$
black	0 V	0 V	0 V	0 V	0 V
red	DC 5 V/ 10-30 V	DC 5 V/ 10-30 V	DC 5 V/ 10-30 V	DC 5 V/ 10-30 V	DC 5 V/ 10-30 V
brown	$\overline{\text{Alarm}}$	$\overline{\text{Alarm}}$	$\overline{\text{Alarm}}$	$\overline{\text{Alarm}}$	$\overline{\text{Alarm}}$

## ELECTRICAL CONNECTIONS

Multiturn, cable (only AC 61 - Parallel)

10 cm cable with Sub-D connector, 37 pole			10 cm cable with Sub-D connector, 37 pole		
Cable (TPE)	Pin	Connection	Cable (TPE)	Pin	Connection
brown	2	S0	white/blue	14	M4 <sup>1</sup>
green	21	S1	brown/blue	33	M5 <sup>1</sup>
yellow	3	S2	white/red	15	M6 <sup>1</sup>
grey	22	S3	brown/red	34	M7 <sup>1</sup>
pink	4	S4	white/black	16	M8 <sup>2</sup>
violet	23	S5	brown/black	35	M9 <sup>2</sup>
grey/pink	5	S6	grey/green	17	M10 <sup>2</sup>
red/blue	24	S7	yellow/grey	36	M11 <sup>2</sup>
white/green	6	S8	pink/green	18	Alarm
brown/green	25	S9	yellow/pink	10	Direction
white/yellow	7	S10	green/blue	30	Latch
yellow/brown	26	S11	yellow/blue	12	Tristate
white/grey	8	M0	red (0.5mm <sup>2</sup> )	13	DC 10-30 V
grey/brown	27	M1	white (0.5mm <sup>2</sup> )	31	DC 10-30 V
white/pink	9	M2	blue (0.5mm <sup>2</sup> )	1	0 V
pink/brown	28	M3	black (0.5mm <sup>2</sup> )	20	0 V

<sup>1</sup> N. C. with resolution 16 Bit (4 Bit MT)<sup>2</sup> N. C. with resolution 16 Bit or 20 Bit (4 or 8 Bit MT)

## DIMENSIONED DRAWINGS

see chapter "Dimensioned drawings AC 59 / AC 61", starting page 232

### ORDERING INFORMATION

Type	Resolution <sup>1,2,3</sup>	Supply voltage	Flange, Protection, Shaft	Interface	Connection
<input type="checkbox"/>	<input type="text"/>	<input type="checkbox"/>	<input type="checkbox"/>	<input type="checkbox"/>	<input type="checkbox"/>
<b>AC59</b> <b>AC61</b>	<b>0010</b> 10 Bit ST <b>0012</b> 12 Bit ST <b>0013</b> 13 Bit ST <b>0014</b> 14 Bit ST <b>0017</b> 17 Bit ST <b>0360</b> 360 increments ST <b>0720</b> 720 increments ST <b>0412</b> 4 Bit MT + 12 Bit ST (AC 61) <b>0812</b> 8 Bit MT + 12 Bit ST (AC 61) <b>1212</b> 12 Bit MT + 12 Bit ST (AC 61)	<b>A</b> DC 5 V <b>E</b> DC 10 - 30 V	<b>Q.76</b> Square, IP67, 9.52 mm <b>Q.72</b> Square, IP67, 10 mm	<b>PB</b> Parallel binary <b>PG</b> Parallel Gray	<b>A</b> Cable, axial <b>B</b> Cable, radial

<sup>1</sup> Resolution 360 increments ST with Offset 76 (value range 76...435)

<sup>2</sup> Resolution 720 increments ST with Offset 152 (value range 152...871)

<sup>3</sup> AC59 only with ST (only AC 59)

### ORDERING INFORMATION

#### Selection of cable length

Versions with cable outlet (connection A, B, E or F) are available with various lengths of cable. To order your desired cable length, please add the respective code to the end of your ordering code. Further cable lengths on request.

Code	Cable length
without code	1.5 m
-D0	3 m
-F0	5 m
-K0	10 m
-P0	15 m
-U0	20 m
-V0	25 m

### ACCESSORIES

see chapter "Accessories", starting page 322

## Absolute

## Profibus



Version AC 61 with bus cover

- Compact design
- Protection class IP67
- High corrosion resistance
- Robust design
- Resolution up to 26 Bit (14 Bit ST, 12 Bit MT)
- Bus cover
- Programmable: Resolution, Preset, Direction
- Output of speed, acceleration
- Applications: packaging machine for food and beverage, ship equipment (e.g. cranes, winches, cable laying ships), offshore applications



### GENERAL INFORMATION

The absolute stainless steel encoders are available in the Versions AC 59 and AC 61.

- AC 59: drawn stainless steel housing, only together with cable outlet, no access to control elements
- AC 61: machined housing, possible with cable or bus cover, access to control elements (DIP switch, Reset switch)

### TECHNICAL DATA mechanical

Housing diameter	61.5 mm
Shaft diameter	9.52 mm / 10 mm (Solid shaft)
Flange (Mounting of housing)	Square flange 63.5 mm
Protection class shaft input (EN 60529)	IP67
Protection class housing (EN 60529)	IP67
Shaft load axial / radial	40 N / 60 N
Max. speed	max. 6000 rpm (continuous), max. 10 000 rpm (short term)
Torque	≤ 1 Ncm
Moment of inertia	approx. 20 gcm <sup>2</sup>
Vibration resistance (DIN EN 60068-2-6)	100 m/s <sup>2</sup> (10 ... 500 Hz)
Shock resistance (DIN EN 60068-2-27)	1000 m/s <sup>2</sup> (6 ms)
Operating temperature	-40 °C ... +85 °C
Storage temperature	-40 °C ... +85 °C
Material shaft	Stainless Steel
Material housing	Stainless Steel
Weight	approx. 1180 g
Connection	Bus cover with 3 sealed cable exits

### TECHNICAL DATA electrical

General design	as per DIN EN 61010-1, protection class III, contamination level 2, overvoltage class II
Supply voltage	DC 10-30 V
Max. current w/o load	220 mA (ST), 250 mA (MT)
EMC	EN 61326: Class A
Resolution singleturn	10 - 14 Bit

## Absolute

## Profibus

### TECHNICAL DATA electrical (continued)

Resolution multiturn	12 Bit
Output code	Binary
Drives	RS 485
Linearity	$\pm \frac{1}{2}$ LSB ( $\pm 1$ LSB for resolution 13, 14, 25, 26 Bit)
Profile/ protocol	Profibus DP with encoder profile class C2 (parameterizable)
Programmable	Resolution, Preset, Direction
Integrated special functions	Speed, Acceleration, Operating time
Baud rate	is automatically set within a range of 9.6 KBaud through 12 MBaud
Device address	adjustable with DIP switches, via fieldbus (optional)
Bus termination resistor	set via DIP switches

**STARTUP** (The encoder can be easily and quickly installed and programmed with the GSD file.)

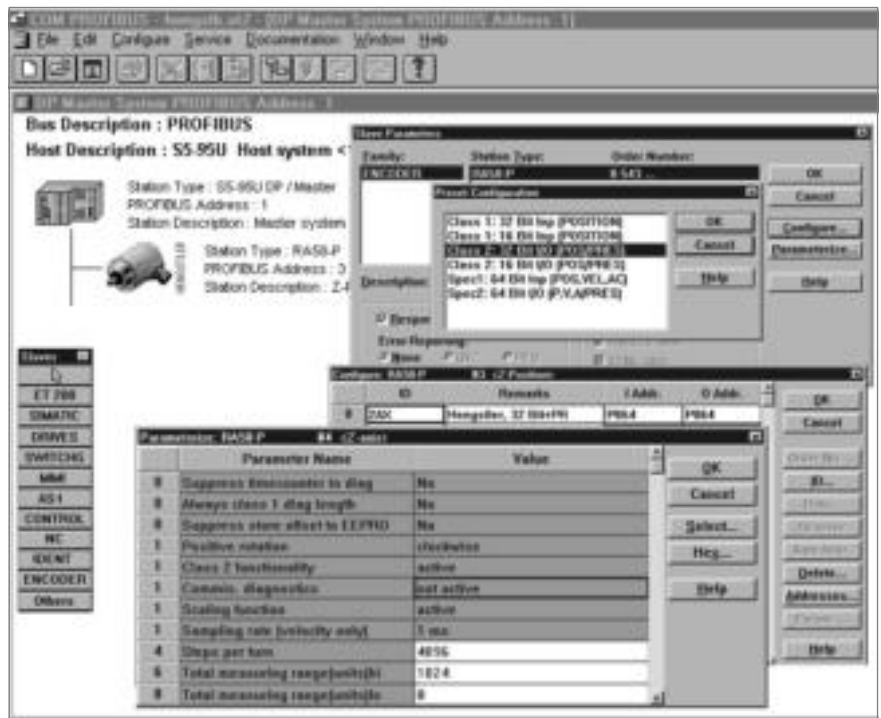

### ELECTRICAL CONNECTIONS Bus cover with 3 sealed cable exits

Connecting Terminal	Signal
1	UB in (DC 10 - 30V)
2	0 V in
3	UB out
4	0 V out
5	B in
6	A in
7	B out
8	A out

### DIMENSIONED DRAWINGS

see chapter "Dimensioned drawings AC 59 / AC 61", starting page 232

### ORDERING INFORMATION

Type	Resolution	Supply voltage	Flange, Protection, Shaft	Interface	Connection
<input type="checkbox"/>	<input type="checkbox"/>	<input type="checkbox"/>	<input type="checkbox"/>	<input type="checkbox"/>	<input type="checkbox"/>
<b>AC61</b>	<b>0010</b> 10 Bit ST <b>0012</b> 12 Bit ST <b>0013</b> 13 Bit ST <b>0014</b> 14 Bit ST <b>1212</b> 12 Bit MT + 12 Bit ST <b>1213</b> 12 Bit MT + 13 Bit ST <b>1214</b> 12 Bit MT + 14 Bit ST	<b>E</b> DC 10 - 30 V	<b>Q.76</b> Square, IP67, 9.52 mm <b>Q.72</b> Square, IP67, 10 mm	<b>DP</b> Profibus	<b>Z</b> Bus cover with 3 sealed cable exits

### ACCESSORIES

see chapter "Accessories", starting page 322



## Absolute

## CANopen



Version AC 61 with bus cover

- Compact design
- Protection class IP67
- High corrosion resistance
- Robust design
- Resolution up to 28 Bit (16 Bit ST, 12 Bit MT)
- Versions with cable or demountable bus cover
- Programmable: Resolution, Preset, Offset, Direction
- Output of speed, acceleration
- Applications: packaging machine for food and beverage, ship equipment (e.g. cranes, winches, cable laying ships), offshore applications



### GENERAL INFORMATION

The absolute stainless steel encoders are available in the Versions AC 59 and AC 61.

- AC 59: drawn stainless steel housing, only together with cable outlet, no access to control elements
- AC 61: machined housing, possible with cable or bus cover, access to control elements (DIP switch, Reset switch)

### TECHNICAL DATA mechanical

Housing diameter	61.5 mm
Shaft diameter	9.52 mm / 10 mm (Solid shaft)
Flange (Mounting of housing)	Square flange 63.5 mm
Protection class shaft input (EN 60529)	IP67
Protection class housing (EN 60529)	IP67
Shaft load axial / radial	40 N / 60 N
Max. speed	max. 6000 rpm (continuous), max. 10 000 rpm (short term)
Torque	≤ 1 Ncm
Moment of inertia	approx. 20 gcm <sup>2</sup>
Vibration resistance (DIN EN 60068-2-6)	100 m/s <sup>2</sup> (10 ... 500 Hz)
Shock resistance (DIN EN 60068-2-27)	1000 m/s <sup>2</sup> (6 ms)
Operating temperature	-40 °C ... +85 °C
Storage temperature	-40 °C ... +85 °C
Material shaft	Stainless Steel
Material housing	Stainless Steel
Weight	approx. 980 g with 1.5 m cable / 1180 g with bus cover
Connection	Cable, axial or radial Bus cover with 3 sealed cable exits

### TECHNICAL DATA electrical

General design	as per DIN EN 61010-1, protection class III, contamination level 2, overvoltage class II
Supply voltage	DC 10-30 V
Max. current w/o load	220 mA (ST), 250 mA (MT)
EMC	EN 61326: Class A

## Absolute

## CANopen

### TECHNICAL DATA electrical (continued)

Resolution singleturn	10 - 16 Bit
Resolution multiturn	12 Bit
Output code	Binary
Linearity	$\pm \frac{1}{2}$ LSB ( $\pm 1$ LSB for resolution 13, 14, 25, 26 Bit)
Profile/ protocol	CANopen according to DS 301 with profile DSP 406, programmable encoder according class C2
Programmable	Resolution, Preset, Offset, Direction
Integrated special functions	Speed, Acceleration, Limit values, Operating time
Baud rate	set via DIP switches within a range of 10 through 1000 Kbit/s
Bus termination resistor	set via DIP switches
Updating of values	every millisecond (adjustable), on request
Basic identifier	set via DIP switches

### ELECTRICAL CONNECTIONS 12 pole / cable

TPE cable	Cable pairs	Signal
yellow	Pair 1	CAN in+
green		CAN in -
pink	Pair 2	CAN out+
grey		CAN out -
blue		CAN GND in
brown		CAN GND out
white	Pair 3	UB in
brown		0 V in
screen	screen	screen

### ELECTRICAL CONNECTIONS Bus cover with 3 sealed cable exits

Connecting block KL 1 (10 pole)	
No.	Signal name
1	UB in (DC 10-30V)
2	0 V in
3	CAN in - (dominant L)
4	CAN in + (dominant H)
5	CAN GND in
6	CAN GND out
7	CAN out + (dominant H)
8	CAN out - (dominant L)
9	0 V out
10	UB out (DC 10-30V)

### DIMENSIONED DRAWINGS

see chapter "Dimensioned drawings AC 59 / AC 61", starting page 232

### ORDERING INFORMATION

Type	Resolution	Supply voltage	Flange, Protection, Shaft	Interface	Connection
<input type="checkbox"/>	<input type="checkbox"/>	<input type="checkbox"/>	<input type="checkbox"/>	<input type="checkbox"/>	<input type="checkbox"/>
<b>AC61</b>	<b>0010</b> 10 Bit ST <b>0012</b> 12 Bit ST <b>0013</b> 13 Bit ST <b>0014</b> 14 Bit ST <b>0016</b> 16 Bit ST <b>1212</b> 12 Bit MT + 12 Bit ST <b>1213</b> 12 Bit MT + 13 Bit ST <b>1214</b> 12 Bit MT + 14 Bit ST <b>1216</b> 12 Bit MT + 16 Bit ST	<b>E</b> DC 10 - 30 V	<b>0.76</b> Square, IP67, 9.52 mm <b>0.72</b> Square, IP67, 10 mm	<b>OL</b> CANopen	<b>A</b> Cable, axial <b>B</b> Cable, radial <b>Z</b> Bus cover with 3 sealed cable exits

### ORDERING INFORMATION

#### Selection of cable length

Versions with cable outlet (connection A, B, E or F) are available with various lengths of cable. To order your desired cable length, please add the respective code to the end of your ordering code. Further cable lengths on request.

Code	Cable length
without code	1.5 m
-D0	3 m
-F0	5 m
-K0	10 m
-P0	15 m
-U0	20 m
-V0	25 m

### ACCESSORIES

see chapter "Accessories", starting page 322

## Absolute

## CANlayer2



Version AC 61 with bus cover

- Compact design
- Protection class IP67
- High corrosion resistance
- Robust design
- Resolution up to 26 Bit (14 Bit ST, 12 Bit MT)
- Versions with cable or demountable bus cover
- Applications: packaging machine for food and beverage, ship equipment (e.g. cranes, winches, cable laying ships), offshore applications



## GENERAL INFORMATION

The absolute stainless steel encoders are available in the Versions AC 59 and AC 61.

- AC 59: drawn stainless steel housing, only together with cable outlet, no access to control elements
- AC 61: machined housing, possible with cable or bus cover, access to control elements (DIP switch, Reset switch)

TECHNICAL DATA  
mechanical

Housing diameter	61.5 mm
Shaft diameter	9.52 mm / 10 mm (Solid shaft)
Flange (Mounting of housing)	Square flange 63.5 mm
Protection class shaft input (EN 60529)	IP67
Protection class housing (EN 60529)	IP67
Shaft load axial / radial	40 N / 60 N
Max. speed	max. 6000 rpm (continuous), max. 10 000 rpm (short term)
Torque	≤ 1 Ncm
Moment of inertia	approx. 20 gcm <sup>2</sup>
Vibration resistance (DIN EN 60068-2-6)	100 m/s <sup>2</sup> (10 ... 500 Hz)
Shock resistance (DIN EN 60068-2-27)	1000 m/s <sup>2</sup> (6 ms)
Operating temperature	-40 °C ... +85 °C
Storage temperature	-40 °C ... +85 °C
Material shaft	Stainless Steel
Material housing	Stainless Steel
Weight	approx. 980 g with 1.5 m cable / 1180 g with bus cover
Connection	Cable, axial or radial Bus cover with 3 sealed cable exits

TECHNICAL DATA  
electrical

General design	as per DIN EN 61010-1, protection class III, contamination level 2, overvoltage class II
Supply voltage	DC 10-30 V
Max. current w/o load	220 mA (ST), 250 mA (MT)
EMC	EN 61326: Class A
Resolution singleturn	10 - 14 Bit
Resolution multiturn	12 Bit

## Absolute

## CANlayer2

**TECHNICAL DATA**  
**electrical (continued)**

Output code	Binary
Linearity	$\pm 1/2$ LSB ( $\pm 1$ LSB for resolution 13, 14, 25, 26 Bit)
Profile/ protocol	CAN 2.0 A
Programmable	Direction, Limit values
Baud rate	set via DIP switches within a range of 10 through 1000 Kbit/s
Bus termination resistor	set via DIP switches
Updating of values	every millisecond
Basic identifier	set via DIP switches

**ELECTRICAL CONNECTIONS**  
**12 pole / cable**

TPE cable	Cable pairs	Signal
yellow	Pair 1	CAN in+
green		CAN in -
pink	Pair 2	CAN out+
grey		CAN out -
blue		CAN GND in
brown		CAN GND out
white	Pair 3	UB in
brown		0 V in
screen	screen	screen

**ELECTRICAL CONNECTIONS**  
**Bus cover with 3 sealed cable exits**

Connecting block KL 1 (10 pole)	
No.	Signal name
1	UB in (DC 10-30V)
2	0 V in
3	CAN in - (dominant L)
4	CAN in + (dominant H)
5	CAN GND in
6	CAN GND out
7	CAN out + (dominant H)
8	CAN out - (dominant L)
9	0 V out
10	UB out (DC 10-30V)

**DIMENSIONED DRAWINGS**

see chapter "Dimensioned drawings AC 59 / AC 61", starting page 232

### ORDERING INFORMATION

Type	Resolution	Supply voltage	Flange, Protection, Shaft	Interface	Connection
<input type="checkbox"/>	<input type="checkbox"/>	<input type="checkbox"/>	<input type="checkbox"/>	<input type="checkbox"/>	<input type="checkbox"/>
<b>AC61</b>	<b>0010</b> 10 Bit ST <b>0012</b> 12 Bit ST <b>0013</b> 13 Bit ST <b>0014</b> 14 Bit ST <b>1212</b> 12 Bit MT + 12 Bit ST <b>1213</b> 12 Bit MT + 13 Bit ST <b>1214</b> 12 Bit MT + 14 Bit ST	<b>E</b> DC 10 - 30 V	<b>0.76</b> Square, IP67, 9.52 mm <b>0.72</b> Square, IP67, 10 mm	<b>CL</b> CANLayer2	<b>A</b> Cable, axial <b>B</b> Cable, radial <b>Z</b> Bus cover with 3 sealed cable exits

### ORDERING INFORMATION Selection of cable length

Versions with cable outlet (connection A, B, E or F) are available with various lengths of cable. To order your desired cable length, please add the respective code to the end of your ordering code. Further cable lengths on request.

Code	Cable length
without code	1.5 m
-D0	3 m
-F0	5 m
-K0	10 m
-P0	15 m
-U0	20 m
-V0	25 m

### ACCESSORIES

see chapter "Accessories", starting page 322

## Absolute

## DeviceNet



Version AC 61 with bus cover

- Compact design
- Protection class IP67
- High corrosion resistance
- Robust design
- Resolution up to 26 Bit (14 Bit ST, 12 Bit MT)
- Bus cover
- Programmable: Resolution, Preset, Direction
- Allan-Bradley compatible
- Applications: packaging machine for food and beverage, ship equipment (e.g. cranes, winches, cable laying ships), offshore applications



### GENERAL INFORMATION

The absolute stainless steel encoders are available in the Versions AC 59 and AC 61.

- AC 59: drawn stainless steel housing, only together with cable outlet, no access to control elements
- AC 61: machined housing, possible with cable or bus cover, access to control elements (DIP switch, Reset switch)

### TECHNICAL DATA mechanical

Housing diameter	61.5 mm
Shaft diameter	9.52 mm / 10 mm (Solid shaft)
Flange (Mounting of housing)	Square flange 63.5 mm
Protection class shaft input (EN 60529)	IP67
Protection class housing (EN 60529)	IP67
Shaft load axial / radial	40 N / 60 N
Max. speed	max. 6000 rpm (continuous), max. 10 000 rpm (short term)
Torque	≤ 1 Ncm
Moment of inertia	approx. 20 gcm <sup>2</sup>
Vibration resistance (DIN EN 60068-2-6)	100 m/s <sup>2</sup> (10 ... 500 Hz)
Shock resistance (DIN EN 60068-2-27)	1000 m/s <sup>2</sup> (6 ms)
Operating temperature	-40 °C ... +85 °C
Storage temperature	-40 °C ... +85 °C
Material shaft	Stainless Steel
Material housing	Stainless Steel
Weight	approx. 1180 g
Connection	Bus cover with 2 sealed cable exits

### TECHNICAL DATA electrical

General design	as per DIN EN 61010-1, protection class III, contamination level 2, overvoltage class II
Supply voltage	DC 10-30 V
Max. current w/o load	220 mA (ST), 250 mA (MT)
EMC	Noise emission according to EN 50081-2 Immunity to interference according to EN 50082-2

## Absolute

## DeviceNet

### TECHNICAL DATA electrical (continued)

EMC	EN 61326: Class A
Resolution singleturn	10 - 14 Bit
Resolution multiturn	12 Bit
Output code	Binary
Interface	CAN High-Speed according to ISO/DIS 11898 CAN specification 2.0 A (11-Bit-Identifier)
Linearity	$\pm \frac{1}{2}$ LSB ( $\pm 1$ LSB for resolution 13, 14, 25, 26 Bit)
Profile/ protocol	DeviceNet according to Rev. 2.0, programmable encoder
Programmable	Resolution, Preset, Direction
Baud rate	set via DIP switches to 125, 250, 500 Kbaud
Bus termination resistor	set via DIP switches
Updating of values	every 5 Milliseconds
MAC-ID	set via DIP switches

### RECOMMENDED DATA TRANSFER Lead type A

Shaft resistance	135...165 $\Omega$ (3...20MHz)
Operating capacity	< 30pF/m
Loop impedance	< 110 $\Omega$ /km
Strand diameter	> 0.64 mm
Strand cross section	> 0.34 mm <sup>2</sup>

### Transfer speeds

Segment length	kbit/s
500 m	125
250 m	250
100 m	500

### STARTUP (the encoder can be easily and quickly installed and programmed with the EDS file)

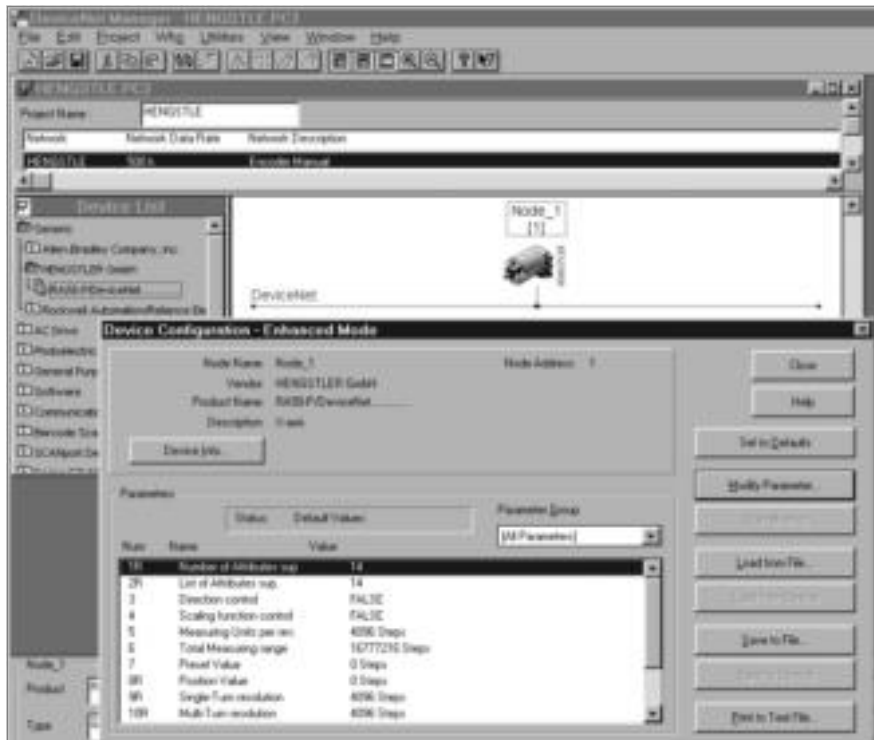



**Absolute**

**DeviceNet**

**ELECTRICAL CONNECTIONS**  
 Bus cover with 2 sealed cable exits

Terminals	
No.	Signal name
1	UB in (DC 10 - 30V)
2	0 V in
3	CAN-L
4	CAN-H
5	DRAIN
6	DRAIN
7	DRAIN
8	CAN-L
9	0 V out
10	UB out (DC 10 - 30V)

**DIMENSIONED DRAWINGS**

see chapter "Dimensioned drawings AC 59 / AC 61", starting page 232

**ORDERING INFORMATION**

Type	Resolution	Supply voltage	Flange, Protection, Shaft	Interface	Connection
<input type="checkbox"/>	<input type="text"/>	<input type="checkbox"/>	<input type="text"/>	<input type="checkbox"/>	<input type="checkbox"/>
<b>AC61</b>	<b>0010</b> 10 Bit ST <b>0012</b> 12 Bit ST <b>0013</b> 13 Bit ST <b>0014</b> 14 Bit ST <b>1212</b> 12 Bit MT + 12 Bit ST <b>1213</b> 12 Bit MT + 13 Bit ST <b>1214</b> 12 Bit MT + 14 Bit ST	<b>E</b> DC 10 - 30 V	<b>0.76</b> Square, IP67, 9.52 mm <b>0.72</b> Square, IP67, 10 mm	<b>VD</b> DeviceNet	<b>Z</b> Bus cover with 2 sealed cable exits

**ACCESSORIES**

see chapter "Accessories", starting page 322

## Absolute

## Interbus



Version AC 61 with bus cover

- Compact design
- Protection class IP67
- High corrosion resistance
- Robust design
- Resolution up to 24 Bit (12 Bit ST, 12 Bit MT)
- Resolution programmable
- Preset (K3)
- Direction (K3)
- Bus cover
- Applications: packaging machine for food and beverage, ship equipment (e.g. cranes, winches, cable laying ships), offshore applications



### GENERAL INFORMATION

The absolute stainless steel encoders are available in the Versions AC 59 and AC 61.

- AC 59: drawn stainless steel housing, only together with cable outlet, no access to control elements
- AC 61: machined housing, possible with cable or bus cover, access to control elements (DIP switch, Reset switch)

### TECHNICAL DATA mechanical

Housing diameter	61.5 mm
Shaft diameter	9.52 mm / 10 mm (Solid shaft)
Flange (Mounting of housing)	Square flange 63.5 mm
Protection class shaft input (EN 60529)	IP67
Protection class housing (EN 60529)	IP67
Shaft load axial / radial	40 N / 60 N
Max. speed	max. 6000 rpm (continuous), max. 10 000 rpm (short term)
Torque	≤ 1 Ncm
Moment of inertia	approx. 20 gcm <sup>2</sup>
Vibration resistance (DIN EN 60068-2-6)	100 m/s <sup>2</sup> (10 ... 500 Hz)
Shock resistance (DIN EN 60068-2-27)	1000 m/s <sup>2</sup> (6 ms)
Operating temperature	-40 °C ... +70 °C
Storage temperature	-40 °C ... +85 °C
Material shaft	Stainless Steel
Material housing	Stainless Steel
Weight	approx. 1180 g
Connection	Bus cover with 3 sealed cable exits

### TECHNICAL DATA electrical

General design	as per DIN EN 61010-1, protection class III, contamination level 2, overvoltage class II
Supply voltage	DC 10-30 V
Max. current w/o load	220 mA (ST, recommended external fuse: T 0.25 A), 250 mA (MT, recommended external fuse: T 0.25 A)

## Absolute

## Interbus

### TECHNICAL DATA electrical (continued)

EMC	Noise emission according to EN 50081-2 Immunity to interference according to EN 50082-2
Resolution singleturn	10 - 12 Bit
Resolution multiturn	12 Bit
Output code	32 Bit binary
Linearity	$\pm \frac{1}{2}$ LSB
Profile/ protocol	ENCOM-Profil K3 = ID-Code 37, K2 = ID-Code 36
Programmable	Resolution, Preset, Offset, Direction
Output current <sup>1</sup>	max. 4.5 A for bus cover with 2x M23 (recommended external fuse: T 4.5 A) max. 2 A for all other connections (recommended external fuse: T 2 A)
Baud rate	500 KBaud
Updating of values	every 600 $\mu$ s

<sup>1</sup> Current with looped through voltage supply

### DATA FORMAT Interbus K2/K3

	Differential signals (RS485) ENCOM profile K3, K2, 32 Bit, binary process data				
Data format	S $\mu$ pi-address	0	1	2	3
(as per Phoenix)	Byte-No.	3	2	1	0
ID-Code K2	36H (= 54 decimal)				
ID-Code K3	37H (= 55 decimal)				

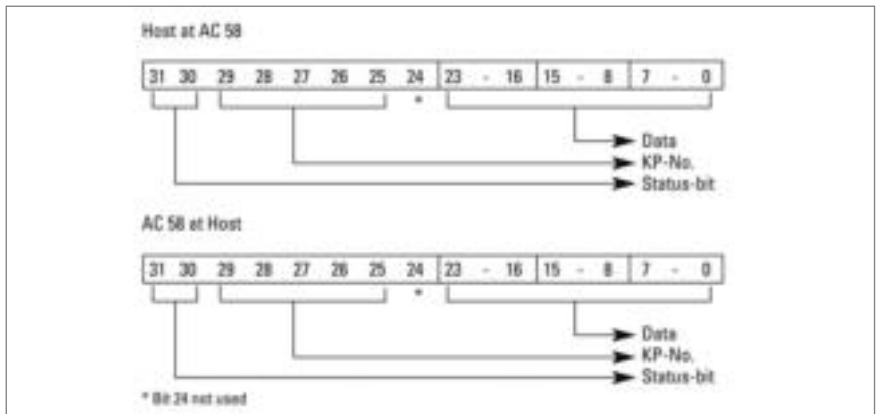

### PROGRAMMABLE FUNKTIONS for Interbus K3

Function (Programming directly via the bus through transfer of configuration parameters)	Preset values (manufacturer's standard settings)	Customer-specific parameters
Code sequence for clockwise (cw) rotation	ascending	
Offset (KP-No. 05)	0	
Preset value (KP-No. 04)	0	
Scaling faktor (KP-No. 08)	1 <sup>1</sup>	

<sup>1</sup> maximum resolution

## Absolute

## Interbus

**ELECTRICAL CONNECTIONS**  
 Bus cover with 3 sealed cable exits

Connection clamp (12 pole)	
1	UB +
2	GND
3	DI1+
4	DI1-
5	D01+
6	D01-
7	D02+
8	D02-
9	DI2+
10	DI2-
11	RBST
12	GND

**DIMENSIONED DRAWINGS**

see chapter "Dimensioned drawings AC 59 / AC 61", starting page 232

**ORDERING INFORMATION**

Type	Resolution	Supply voltage	Flange, Protection, Shaft	Interface	Connection
<input type="checkbox"/>	<input type="text"/>	<input type="checkbox"/>	<input type="text"/>	<input type="checkbox"/>	<input type="checkbox"/>
<b>AC61</b>	<b>0010</b> 10 Bit ST <b>0012</b> 12 Bit ST <b>0013</b> 13 Bit ST <b>0014</b> 14 Bit ST <b>1212</b> 12 Bit MT + 12 Bit ST <b>1213</b> 12 Bit MT + 13 Bit ST <b>1214</b> 12 Bit MT + 14 Bit ST	<b>E</b> DC 10 - 30 V	<b>Q.76</b> Square, IP67, 9.52 mm <b>Q.72</b> Square, IP67, 10 mm	<b>I2</b> Interbus K2 <b>K3</b> Interbus K3	<b>Z</b> Bus cover with 3 sealed cable exits

**ACCESSORIES**

see chapter "Accessories", starting page 322

## Absolute

## SSI programmable

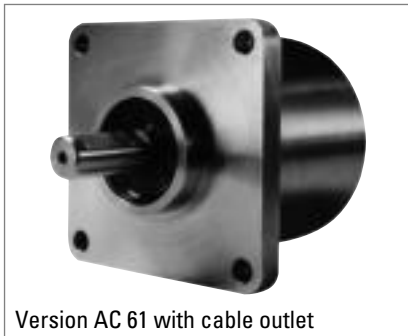

Version AC 61 with cable outlet

- Compact design
- Protection class IP67
- High corrosion resistance
- Robust design
- Resolution up to 29 Bit (17 Bit ST, 12 Bit MT)
- Versions with cable
- Parameterization: Resolution, code type, direction, output format, warning, alarm
- Applications: packaging machine for food and beverage, ship equipment (e.g. cranes, winches, cable laying ships), offshore applications



## GENERAL INFORMATION

The absolute stainless steel encoders are available in the Versions AC 59 and AC 61.

- AC 59: drawn stainless steel housing, only together with cable outlet, no access to control elements
- AC 61: machined housing, possible with cable or bus cover, access to control elements (DIP switch, Reset switch)

TECHNICAL DATA  
mechanical

Housing diameter	61.5 mm
Shaft diameter	9.52 mm / 10 mm (Solid shaft)
Flange (Mounting of housing)	Square flange 63.5 mm
Protection class shaft input (EN 60529)	IP67
Protection class housing (EN 60529)	IP67
Shaft load axial / radial	40 N / 60 N
Max. speed	max. 6000 rpm (continuous), max. 10 000 rpm (short term)
Torque	≤ 1 Ncm
Moment of inertia	approx. 20 gcm <sup>2</sup>
Vibration resistance (DIN EN 60068-2-6)	100 m/s <sup>2</sup> (10 ... 500 Hz)
Shock resistance (DIN EN 60068-2-27)	1000 m/s <sup>2</sup> (6 ms)
Operating temperature	-40 °C ... +70 °C
Storage temperature	-40 °C ... +85 °C
Material shaft	Stainless Steel
Material housing	Stainless Steel
Weight	approx. 980 g with 1.5 m cable
Connection	Cable, axial or radial

TECHNICAL DATA  
electrical

Supply voltage	DC 10-30 V
Max. current w/o load	250 mA (ST / MT)
Resolution singleturn	10 - 17 Bit
Resolution multiturn	12 Bit
Output code	Binary, Gray
Drives	Clock and Data / RS422

## Absolute

## SSI programmable

### TECHNICAL DATA electrical (continued)

Parametrization	Resolution, Code type, Direction, Output format, Warning, Alarm
Control inputs	Direction, Preset 1, Preset 2
Alarm output	Alarm bit
Status LED	Green = ok, red = alarm

### RECOMMENDED DATA TRANSFER RATE bei SSI

The max. data transfer rate depends on the cable length. For Clock /  $\overline{\text{Clock}}$  and Data /  $\overline{\text{Data}}$  please use twisted pairs. Use shielded cable.

Cable length	Frequency
< 50 m	< 400 kHz
< 100 m	< 300 kHz
< 200 m	< 200 kHz
< 400 m	< 100 kHz

### SYNCHRONOUS-SERIAL TRANSFER (SSI)

A clock brush is applied at the SSI interface, causing the encoder data to be serially clocked out. With each new clock brush (min. interval 30 ms) new data is readout. The following main parameters are programmable:

- Preset: Software-Preset and via input/pushbutton settable presets (can be inactivated)
- Offset: Relative shifting of actual encoder value.
- Scaling: The actual value of the encoder is multiplied with the factor  $< 1$  (direct entry, increments per measuring distance or per revolution).
- Direction of rotation: Can be changed via software or input (can be inactivated)

- Output formats SSI: Tree format or standard format (MSB oriented)
- Output code: The choices are Gray or binary code, integer or two's complement representation. Selection of significant bit between 16 and 24 Bit.

In addition, programming of max. 7 status bits is possible:

- up to 4 warning positions
- overspeed
- encoder standstill
- parity
- encoder error
- direction of rotation

### PROGRAMMING with SSI

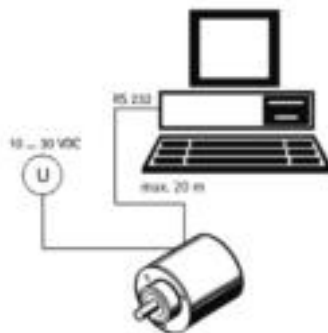

To program the absolute encoder you require a PC, the software WinSSI and the adapter cable.

The encoder is connected to the power supply and the serial interface of your PC with the adapter cable. Using the menu-assisted programme you can then configure the encoder according to the parameters you require.

OUTPUT FORMAT SSI, MSB oriented, Multiturn

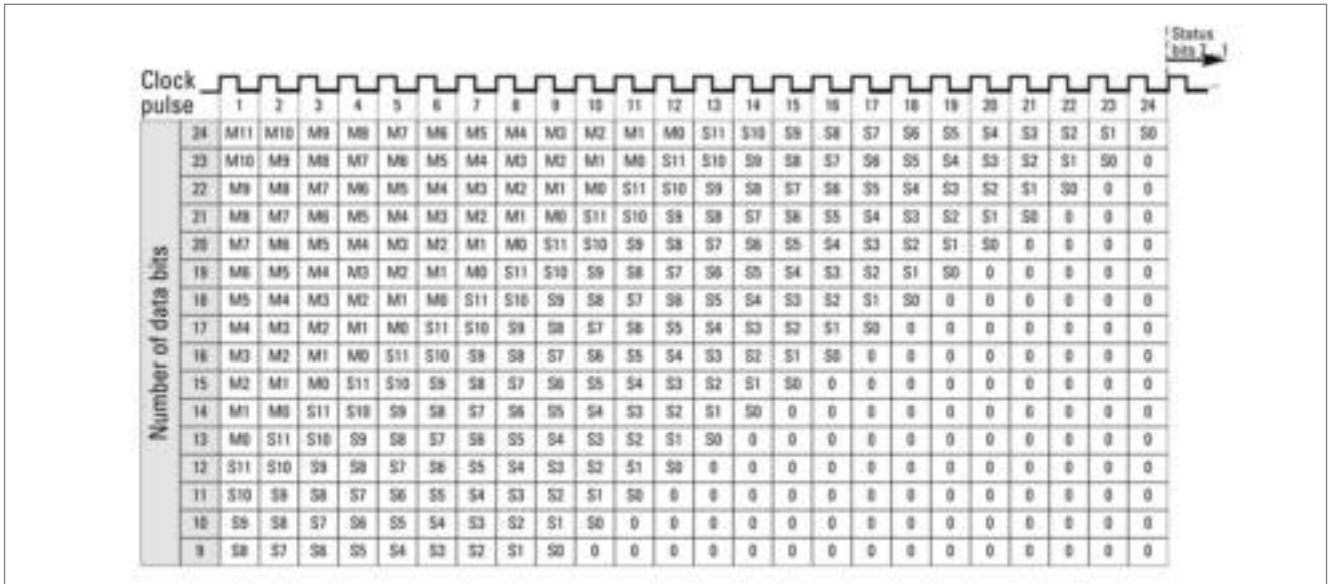

OUTPUT FORMATS SSI, MSB oriented, Multiturn (not scaleable)

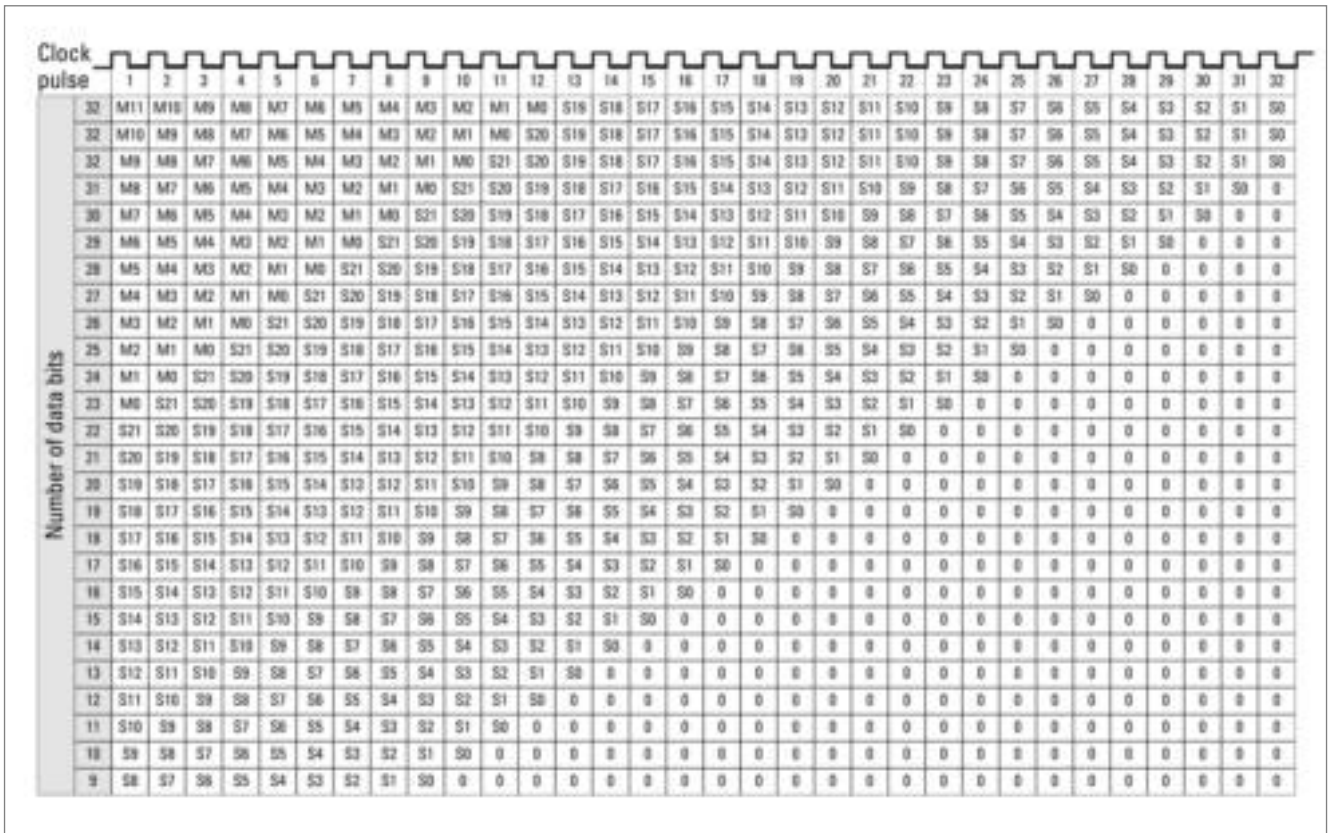

### OUTPUT FORMAT SSI, tree format

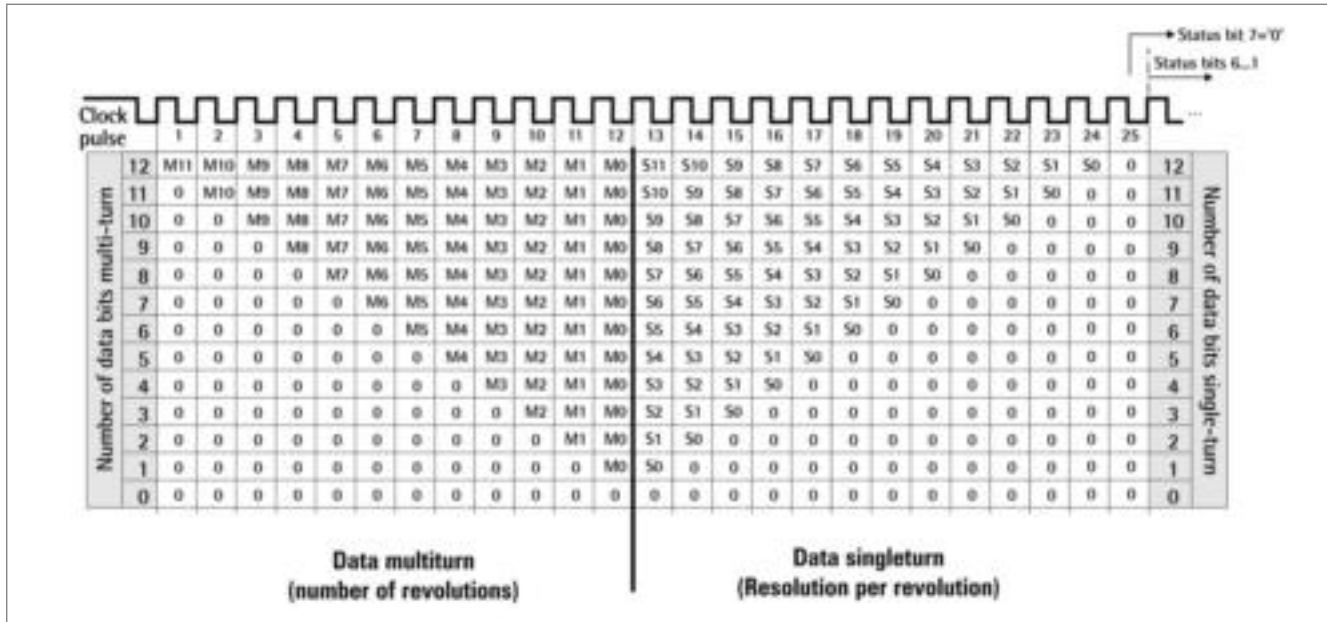

### ELECTRICAL CONNECTIONS

12 pole / cable

Cable Colour	Signal
green	Clock
yellow	Clock
pink	Data
grey	Data
brown	RS 232 TxD
white	RS 232 RxD
black	0 V signal output
blue	Direction
red	Preset 1
violet	Preset 2
white <sup>1</sup>	DC 10 - 30 V
brown <sup>1</sup>	0 V (supply voltage)

<sup>1</sup> bigger cross section 0.5 mm<sup>2</sup>

### DIMENSIONED DRAWINGS

see chapter "Dimensioned drawings AC 59 / AC 61", starting page 232



### ORDERING INFORMATION

Type	Resolution	Supply voltage	Flange, Protection, Shaft	Interface	Connection
<input type="checkbox"/>	<input type="text"/>	<input type="checkbox"/>	<input type="text"/>	<input type="checkbox"/>	<input type="checkbox"/>
<b>AC61</b>	<b>0010</b> 10 Bit ST <b>0012</b> 12 Bit ST <b>0013</b> 13 Bit ST <b>0014</b> 14 Bit ST <b>1212</b> 12 Bit MT + 12 Bit ST <b>1213</b> 12 Bit MT + 13 Bit ST <b>1214</b> 12 Bit MT + 14 Bit ST <b>1217</b> 12 Bit MT + 17 Bit ST higher resolution on request	<b>E</b> DC 10 - 30 V	<b>0.76</b> Square, IP67, 9.52 mm <b>0.72</b> Square, IP67, 10 mm	<b>SP</b> SSI programmable	<b>A</b> Cable, axial <b>B</b> Cable, radial

### ORDERING INFORMATION

#### Selection of cable length

Versions with cable outlet (connection A, B, E or F) are available with various lengths of cable. To order your desired cable length, please add the respective code to the end of your ordering code. Further cable lengths on request.

Code	Cable length
without code	1.5 m
-D0	3 m
-F0	5 m
-K0	10 m
-P0	15 m
-U0	20 m
-V0	25 m

### ACCESSORIES

see chapter "Accessories", starting page 322

DIMENSIONED DRAWINGS

AC 59 Connection cable "A"/ "B"  
Dimensions in mm

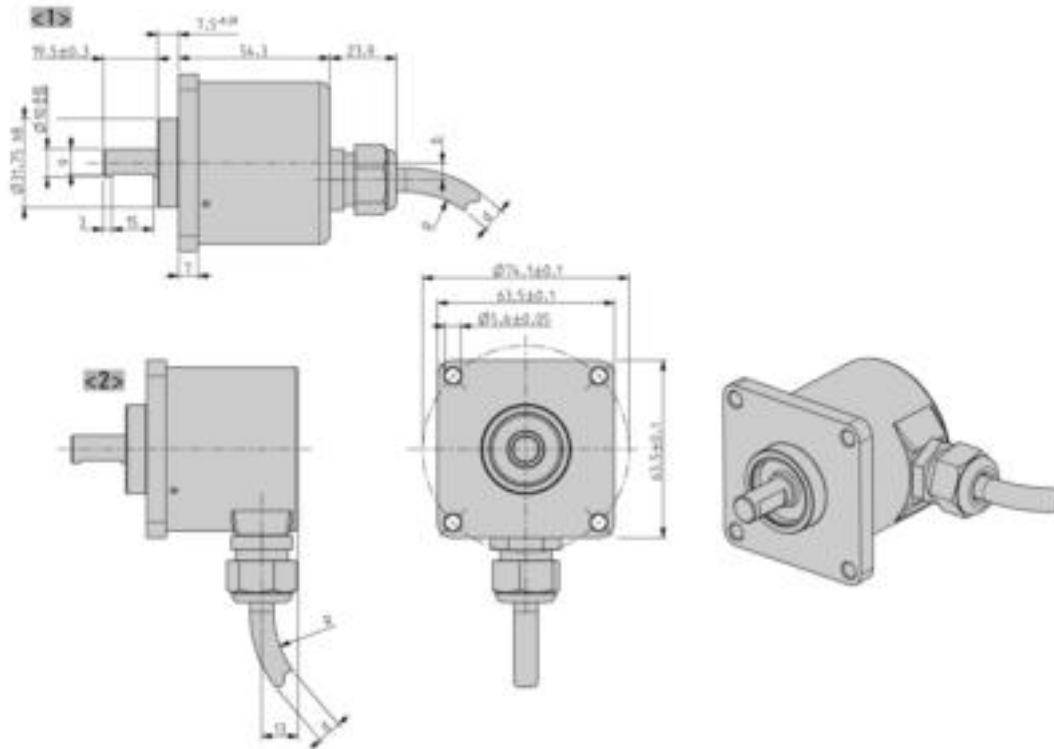

<1> Connection cable "A"

<2> Connection cable "B"

Cable bending radius R for flexible installation  $\geq 15 \times$  cable diameter

Cable bending radius R for fixed installation  $\geq 7.5 \times$  cable diameter

Cable Ø d BiSS/SSI/SSI-P:  $7,1^{+1,2}$

Cable Ø d ST-P:  $7,8^{+0,9}$

# Stainless Industrial Types AC 59 / AC 61

## Absolute Dimensioned Drawings

### DIMENSIONED DRAWINGS (continued)

**AC 61 Connection cable "Z"**  
Interface: Profibus, CANopen, CANlayer2, DeviceNet, Interbus

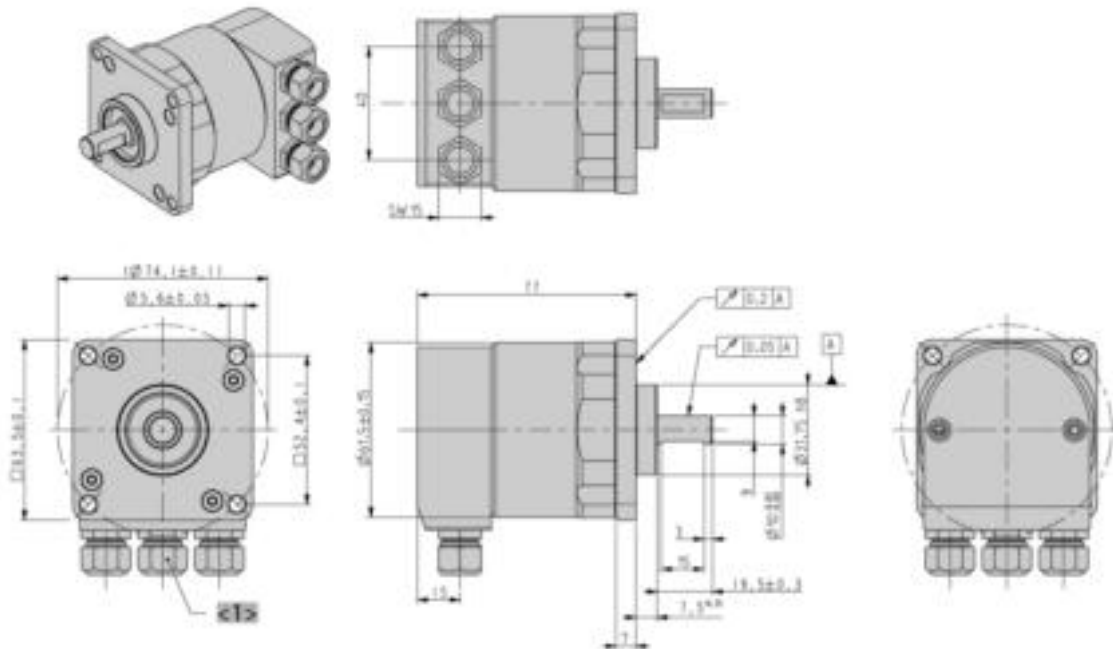

<1> Obsolete with DeviceNet

Dimensions in mm

**AC 61 Connection cable "A"**  
Interface: BiSS, SSI, ST-/ MT-Parallel, SSI-P

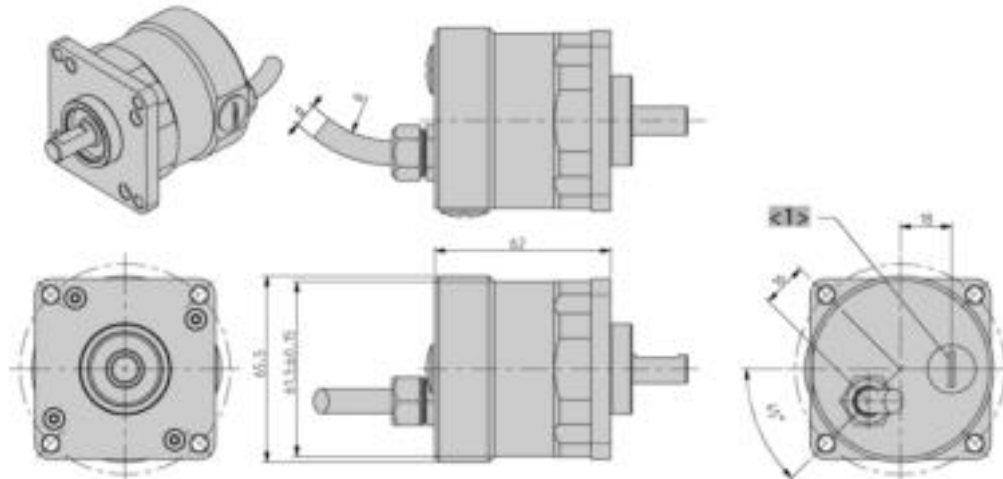

<1> Preset  
Cable bending radius R for flexible installation  $\geq 15 \times$  cable diameter  
Cable bending radius R for fixed installation  $\geq 7.5 \times$  cable diameter  
Cable  $\varnothing$  d BiSS/SSI/SSI-P:  $7,1^{+1,2}$

Cable  $\varnothing$  d ST-P:  $7,8^{+0,9}$   
Cable  $\varnothing$  d MT-P:  $9,3^{+1,3}$   
Cable  $\varnothing$  d Fieldbus:  $7,1^{+1,2}$

Dimensions in mm

### DIMENSIONED DRAWINGS (continued)

#### AC 61 Connection cable "A" Interface: CANopen, CANlayer2

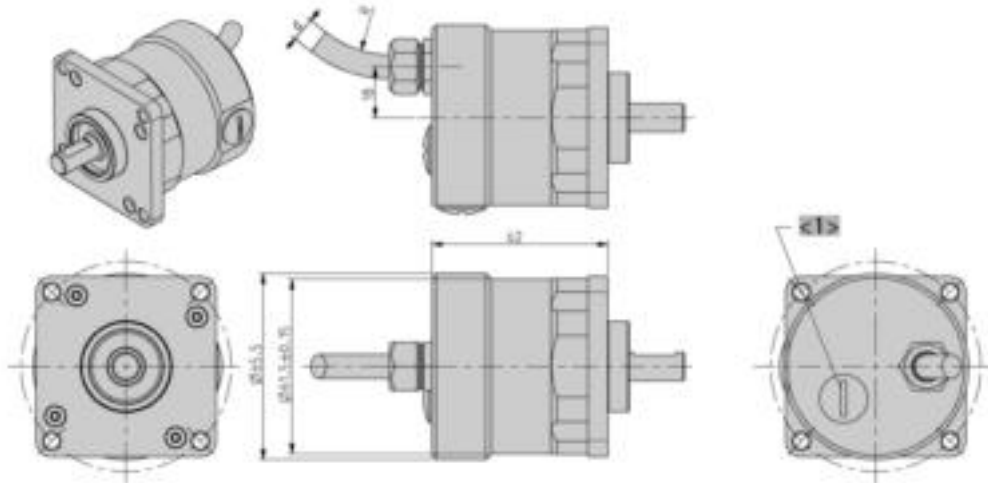

<1> Settings

Cable bending radius R for flexible installation  $\geq 15 \times$  cable diameter

Cable bending radius R for fixed installation  $\geq 7.5 \times$  cable diameter

Cable  $\varnothing$  d BiSS/SSI/SSI-P:  $7,1^{+1,2}$

Cable  $\varnothing$  d ST-P:  $7,8^{+0,9}$

Cable  $\varnothing$  d MT-P:  $9,3^{+1,3}$

Cable  $\varnothing$  d Fieldbus:  $7,1^{+1,2}$

Dimensions in mm

#### AC 61 Connection cable "B"

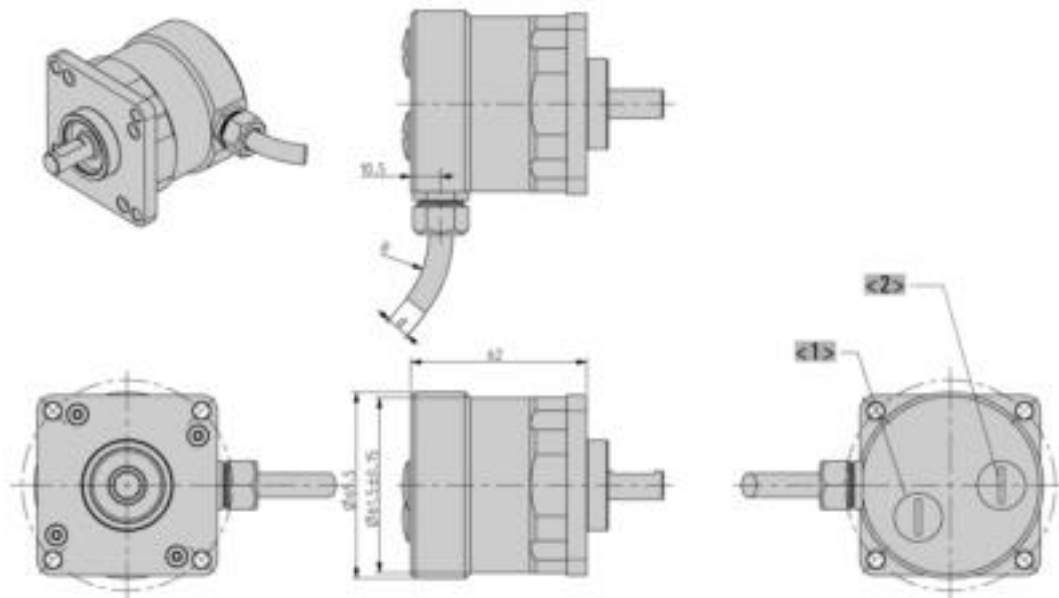

<1> Settings CAN/ CANopen

<2> Preset BiSS, SSI, SSI-P, MT-Parallel

Cable bending radius R for flexible installation  $\geq 15 \times$  cable diameter

Cable bending radius R for fixed installation  $\geq 7.5 \times$  cable diameter

Cable  $\varnothing$  d BiSS/SSI/SSI-P:  $7,1^{+1,2}$

Cable  $\varnothing$  d ST-P:  $7,8^{+0,9}$

Cable  $\varnothing$  d MT-P:  $9,3^{+1,3}$

Cable  $\varnothing$  d Fieldbus:  $7,1^{+1,2}$

Dimensions in mm

## EEx Industrial Types



The absolute encoder line ACURO® and incremental encoder line “RI” are available with explosion proof enclosure “d” under AX70 or AX71 (stainless steel) for absolute encoders and RX70 or RX71 (stainless steel) for incremental encoders.

They are approved by PTB and documented via “Declaration of Conformity” to meet the requirements of safety and health according to EN 50014 and EN 50018. Therefore its usage is permitted in explosive areas, code „Ex II 2 G/D E Ex d II C T4/T6 IP65/ IP66 135°C resp. 85°C“.

For applications under tough environmental conditions and food industry the stainless steel version AX71 and RX71 are available.

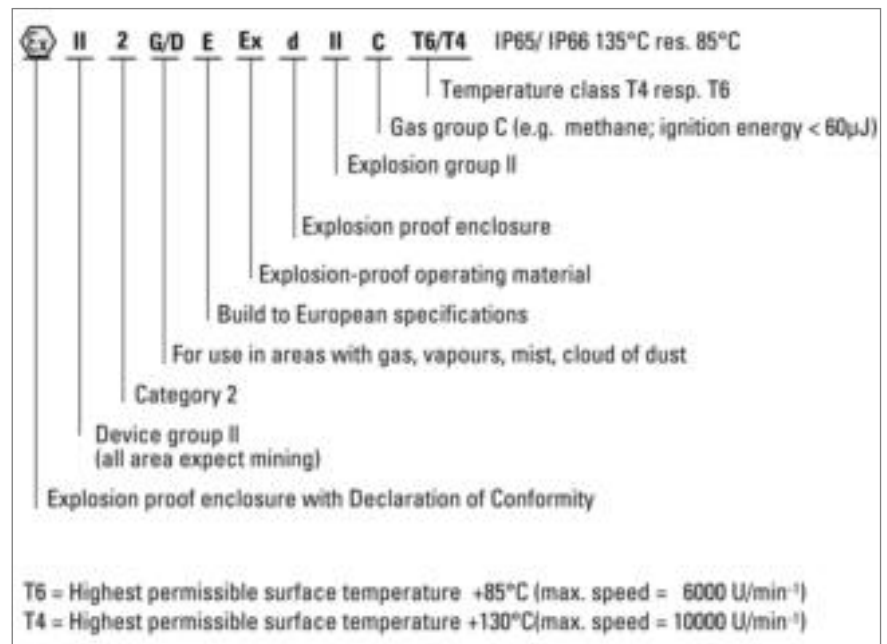

### Examples of applications for explosion proof encoders:

- draw works
- other Oil field applications
- petro chemistry
- enamelling production line
- bottling machines
- mixers
- silo works

**Incremental**



RX 70 - Aluminium



RX 71 - Stainless steel

- Explosion proof class II according to EX II 2 G/D EEX d IIC T6/T4
- Highest working reliability
- Resolution up to 10000 ppr
- Stainless steel version RX71 available
- Applications: enamelling production line, surfacing machines, bottling machines, mixers, silo works



ATEX

CE



**NUMBER OF PULSES**

1 / 2 / 3 / 4 / 5 / 10 / 15 / 20 / 25 / 30 / 35 / 40 / 45 / 50 / 60 / 64 / 70 / 72 / 80 / 100 / 125 / 128 / 144 / 150 / 180 / 200 / 230 / 250 / 256 / 300 / 314 / 350 / 360 / 375 / 400 / 460 / 480 / 500 / 512 / 600 / 625 / 635 / 720 / 750 / 900 / 1000 / 1024 / 1200 / 1250 / 1500 / 1600 / 1800 / 2000 / 2048 / 2500 / 3000 / 3480 / 3600 / 3750 / 3968 / 4000 / 4096 / 4800 / 5000 / 5400 / 6000 / 7200 / 7680 / 8000 / 8192 / 9000 / 10000

Other number of pulses on request

**EX-CLASSIFICATION**

The incremental shaft encoder is available in explosion proof design with explosion proof enclosure "d" under RX 70 and RX 71 (stainless steel).

The PTB has assured with the Declaration of Conformity that the RX 70 / 71 meets the requirements of safety and health according to EN 50014 and EN 50018. Therefore it is approved in explosive areas, code "Ex II 2 G/D E Ex d II C T4/T6 IP65/ IP66 135°C resp. 85°C".

For applications under tough environmental conditions and food industry the stainless steel version RX 71 is available.

Incremental

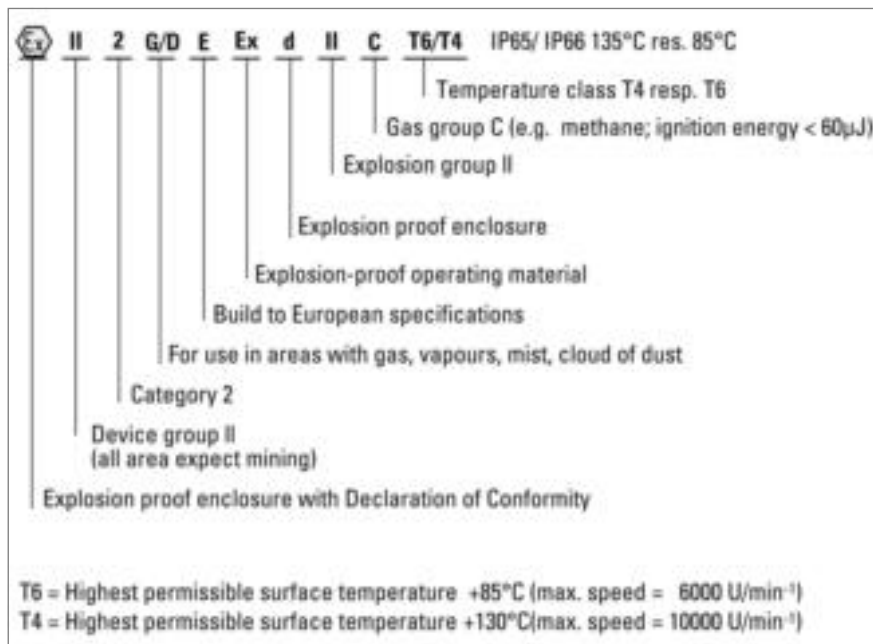

TECHNICAL DATA  
mechanical

Housing diameter	70 mm
Shaft diameter	10 mm (Solid shaft)
Flange (Mounting of housing)	Clamping flange
Protection class shaft input (EN 60529) <sup>1</sup>	T4: IP64 or IP67 T6: IP64
Protection class housing (EN 60529)	T4: IP65 or IP67 T6: IP65
Shaft load axial / radial	50 N / 100 N
Max. speed	T4: max. 10 000 rpm T6: max. 6000 rpm
Torque	≤ 1 Ncm
Moment of inertia	approx. 20 gcm <sup>2</sup>
Vibration resistance (DIN EN 60068-2-6)	10 g = 100 m/s <sup>2</sup> (10 ... 2000 Hz)
Shock resistance (DIN EN 60068-2-27)	100 g = 1000 m/s <sup>2</sup> (6 ms)
Ambient temperature	T4: -25 °C ... +60 °C T6: -25 °C ... +40 °C
Storage temperature	-25 °C ... +85 °C
Material shaft	Stainless Steel
Material housing	RX 70TI: Aluminum RX 71TI: Stainless Steel
Weight	RX 70TI: approx. 1.4 kg RX 71TI: approx. 4.8 kg
Connection <sup>2,3</sup>	Cable, axial

<sup>1</sup> No dust explosion-proof certification for IP64

<sup>2</sup> Standard cable length: 5 m cable, other cable length on request

<sup>3</sup> Connection cable for fixed installation

## Incremental

TECHNICAL DATA  
electrical

General design	as per DIN VDE 0160, protection class III, contamination level 2, overvoltage class II
Supply voltage <sup>1</sup>	RS422 + Sense (T): DC 5 V $\pm$ 10 % RS422 + Alarm (R): $\pm$ 10% DC 5 V or DC 10 - 30 V Push-pull (K), Push-pull antivalent (I): DC 10-30 V
Max. current w/o load	40 mA (DC 5 V), 60 mA (DC 10 V), 30 mA (DC 24 V)
Max. pulse frequency	RS422: 300 kHz Push-pull: 200 kHz
Standard output versions <sup>2,3</sup>	RS422 + Alarm (R): A, B, N, $\bar{A}$ , $\bar{B}$ , $\bar{N}$ , $\overline{\text{Alarm}}$ RS422 + Sense (T): A, B, N, $\bar{A}$ , $\bar{B}$ , $\bar{N}$ , Sense Push-pull (K): A, B, N, $\overline{\text{Alarm}}$ Push-pull complementary (I): A, B, N, $\bar{A}$ , $\bar{B}$ , $\bar{N}$ , $\overline{\text{Alarm}}$
Pulse width error	$\pm$ max. 25° electrical
Number of pulses	1 ... 10 000
Output current	RS 422: $\pm$ 30 mA Push-pull with short-circuit protection: 30 mA (DC 10 - 30 V)
Alarm output	NPN-O.C., max. 5 mA
Pulse shape	Square wave
Pulse duty factor	1:1

<sup>1</sup> Pole protection with supply voltage DC 10 - 30 V

<sup>2</sup> Output code "K" and "I": short-circuit-proof

<sup>3</sup> Output description and technical data see chapter "Technical basics"

ELECTRICAL CONNECTIONS  
Cable PVC

Cable Colour	Cable No.	Output RS 422+ Sense (T)	RS 422+ Alarm (R)	push-pull (K)	push-pull complementary (I)
brown/green	12	DC 5 V	DC 5 / 10 - 30 V	DC 10 - 30 V	DC 10 - 30 V
white/green	11	GND	GND	GND	GND
blue	10	Sense V <sub>CC</sub>			
white	9	Sense GND			
brown	1	Channel A	Channel A	Channel A	Channel A
green	2	Channel $\bar{A}$	Channel $\bar{A}$		Channel $\bar{A}$
grey	3	Channel B	Channel B	Channel B	Channel B
pink	4	Channel $\bar{B}$	Channel $\bar{B}$		Channel $\bar{B}$
red	5	Channel N	Channel N	Channel N	Channel N
black	6	Channel $\bar{N}$	Channel $\bar{N}$		Channel $\bar{N}$
violett	7		$\overline{\text{Alarm}}$	$\overline{\text{Alarm}}$	$\overline{\text{Alarm}}$
screen			Cable screen connected to housing		
Screw terminal			for additional connection of an earth conductor		



Incremental

DIMENSIONED DRAWINGS

IP64

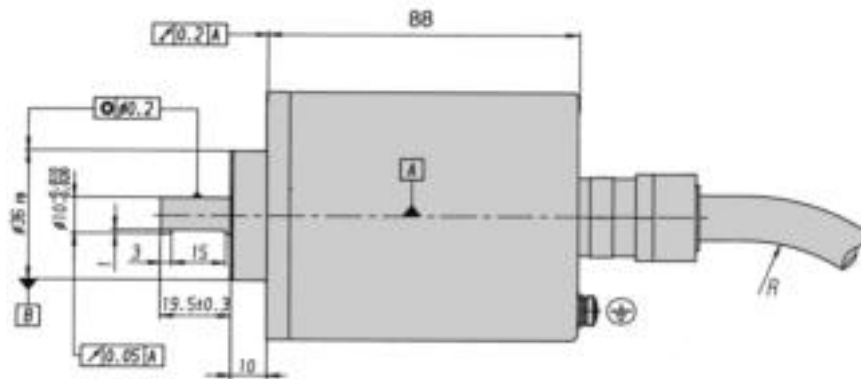

<1> mounting thread M6x12  
Cable bending radius R for flexible installation  $\geq 100$  mm

Cable bending radius R for fixed installation  $\geq 40$  mm

Dimensions in mm

IP67

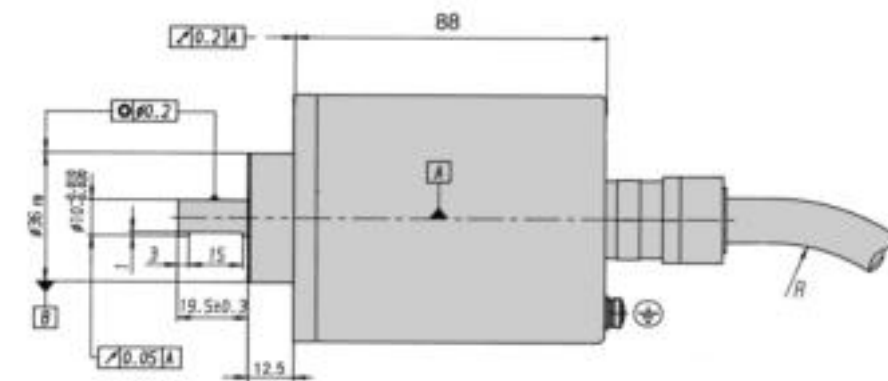

<1> mounting thread M6x12  
Cable bending radius R for flexible installation  $\geq 150$  mm

Cable bending radius R for fixed installation  $\geq 40$  mm

Dimensions in mm

**Incremental**

**ORDERING INFORMATION**

Type	Model	Number of pulses	Supply voltage <sup>1, 2</sup>	Flange, Protection, Shaft <sup>3</sup>	Output	Connection
<input type="checkbox"/>	<input type="checkbox"/>	<input type="checkbox"/>	<input type="checkbox"/>	<input type="checkbox"/>	<input type="checkbox"/>	<input type="checkbox"/>
<b>RX70</b> <b>RX71</b> Stain- less Steel	<b>TI</b> Incre- mental	<b>1 ... 10000</b>	<b>A</b> DC 5 V <b>E</b> DC 10 - 30 V	<b>K.42</b> Clamping, IP64, 10 mm <b>K.72</b> Clamping, IP67, 10 mm	<b>R</b> RS422 +Alarm <b>T</b> RS422 +Sense <b>K</b> Push-pull <b>I</b> Push-pull complemen- tary	<b>E</b> TPE cable, axial

<sup>1</sup> DC 5 V: only with output "T", "R" available

<sup>2</sup> DC 10 - 30 V: only with output "K", "I", "R" available

<sup>3</sup> No dust explosion-proof certification (D) for IP64

**ORDERING INFORMATION**

**Selection of cable length**

Versions with cable outlet (connection A, B, E or F) are available with various lengths of cable. To order your desired cable length, please add the respective code to the end of your ordering code. Further cable lengths on request.

Code	Cable length
-F0 / without code	5 m
-K0	10 m
-P0	15 m
-U0	20 m
-V0	25 m

**ACCESSORIES**

see chapter "Accessories", starting page 322

**Absolute**

**SSI**



Version AX 70 - Aluminium



Version AX 71 - Stainless Steel

- ATEX certification for gas and dust explosion proof
- Same electrical performance as ACURO industry
- Protection class up to IP67
- Diameter only 70 mm
- Robust design
- Also available with stainless steel housing (AX 71 - SSI)
- Resolution up to 29 Bit (17 Bit ST, 12 Bit MT)
- Applications: enamelling production line, petro chemistry, bottling machines, mixers, silo works, mills



**EX-CLASSIFICATION**

The absolute shaft encoder line ACURO is available in explosion proof design with explosion proof enclosure "d" under AX 70 and AX 71 (stainless steel). The PTB has assured with the Declaration of Conformity that the AX 70 / 71 meets the requirements of safety and health according to EN 50014 and EN 50018. Therefore it is approved in explosive areas, code "Ex II 2 G/D E Ex d II C T4/T6 IP65/ IP66 135°C resp. 85°C". For applications under tough environmental conditions and food industry the stainless steel version AX 71 is available.

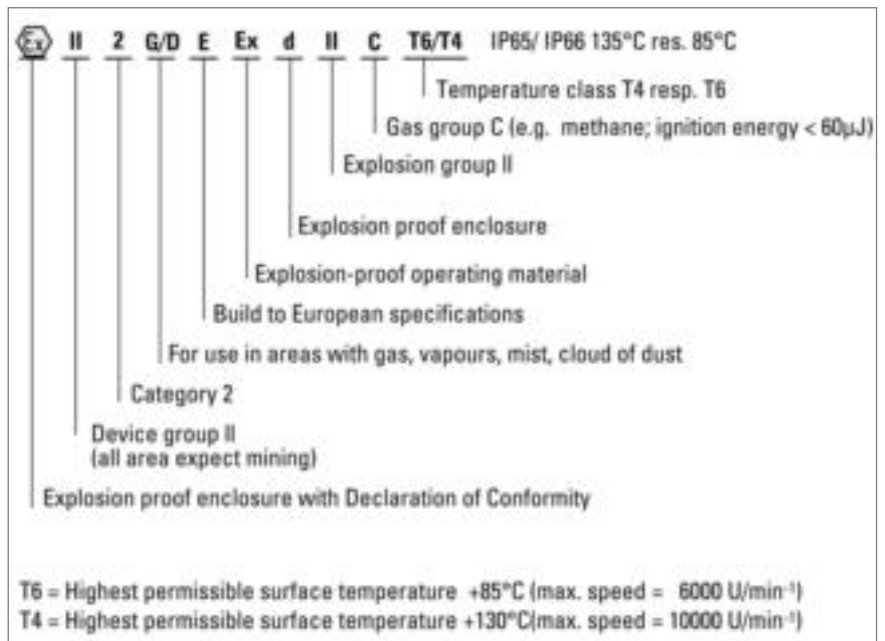

**TECHNICAL DATA**  
mechanical

Housing diameter	70 mm
Shaft diameter	10 mm (Solid shaft)

**Absolute**

**SSI**

**TECHNICAL DATA  
mechanical (continued)**

Flange (Mounting of housing)	Clamping flange
Protection class shaft input (EN 60529) <sup>1</sup>	T4: IP64 or IP67 T6: IP64
Protection class housing (EN 60529)	T4: IP65 or IP67 T6: IP65
Shaft load axial / radial	40 N / 100 N
Max. speed	T4: max. 10 000 rpm T6: max. 6000 rpm
Torque	≤ 1 Ncm
Moment of inertia	approx. 20 gcm <sup>2</sup>
Vibration resistance (DIN EN 60068-2-6)	100 m/s <sup>2</sup> (10 ... 500 Hz)
Shock resistance (DIN EN 60068-2-27)	1000 m/s <sup>2</sup> (6 ms)
Ambient temperature	T4: -40 °C ... +60 °C T6: -40 °C ... +40 °C
Storage temperature	-25 °C ... +85 °C
Material shaft	Stainless Steel
Material housing	AX 70: Aluminum AX 71: Stainless Steel
Weight	AX 70: approx. 1.4 kg AX 71: approx. 4.8 kg
Connection	Cable, axial

<sup>1</sup> No dust explosion-proof (D) for IP64

**TECHNICAL DATA  
electrical**

Supply voltage	DC 10-30 V
Max. current w/o load	220 mA (ST), 250 mA (MT)
Resolution singleturn	10 - 17 Bit
Resolution multiturn	12 Bit
Output code	Binary, Gray
Drives	Clock and Data / RS422
Control inputs	$\overline{\text{Direction}}$
Alarm output	Alarm bit (SSI Option)

**RECOMMENDED DATA TRANSFER RATE  
bei SSI**

The max. data transfer rate depends on the cable length. For Clock /  $\overline{\text{Clock}}$  and Data /  $\overline{\text{Data}}$  please use twisted pairs. Use shielded cable.

Cable length	Frequency
< 50 m	< 400 kHz
< 100 m	< 300 kHz
< 200 m	< 200 kHz
< 400 m	< 100 kHz

## Absolute

## SSI

## ELECTRICAL CONNECTIONS

## Cable

Colour	No.	SSI
white 0.5 mm	12	DC 10 ... 30 V
brown 0.5 mm	11	0 V supply voltage
green	10	$\overline{\text{Clock}}$
yellow	9	Clock
grey	8	$\overline{\text{Data}}$
pink	7	Data
blue	3	$\overline{\text{Direction}}$
black	4	0 V signal output

## DIMENSIONED DRAWINGS

see chapter "Dimensioned drawings AX 70 / AX 71", starting page 253

## ORDERING INFORMATION

Type	Resolution <sup>1,2,3</sup>	Supply voltage	Flange, Protection, Shaft <sup>4,5</sup>	Interface	Connection
<input type="checkbox"/>	<input type="text"/>	<input type="checkbox"/>	<input type="checkbox"/>	<input type="checkbox"/>	<input type="checkbox"/>
<b>AX70</b> <b>AX71</b>	<b>0010</b> 10 Bit ST <b>0012</b> 12 Bit ST <b>0013</b> 13 Bit ST <b>0014</b> 14 Bit ST <b>0017</b> 17 Bit ST <b>0360</b> 360 increments ST <b>0720</b> 720 increments ST <b>1212</b> 12 Bit MT + 12 Bit ST <b>1213</b> 12 Bit MT + 13 Bit ST higher resolution on request	<b>E</b> DC 10 - 30 V	<b>K.42</b> Clamping, IP64, 10 mm <b>K.72</b> Clamping, IP67, 10 mm	<b>SB</b> SSI binary <b>SG</b> SSI Gray	<b>A</b> Cable, axial

<sup>1</sup> Resolution 360 increments ST with Offset 76 (value range 76..435)

<sup>2</sup> Resolution 720 increments ST with Offset 152 (value range 152..871)

<sup>3</sup> When resolution > 14 Bit: max. clock frequency 178 kHz

<sup>4</sup> Dust explosion-proof certification (D) only for IP67

<sup>5</sup> IP67 only with temperature class T4

## ORDERING INFORMATION

## Selection of cable length

Versions with cable outlet (connection A, B, E or F) are available with various lengths of cable. To order your desired cable length, please add the respective code to the end of your ordering code. Further cable lengths on request.

Code	Cable length
-F0 / without code	5 m
-K0	10 m
-P0	15 m
-U0	20 m
-V0	25 m

## ACCESSORIES

see chapter "Accessories", starting page 322

**Absolute**

**Profibus**



Version AX 70 - Aluminium



Version AX 71 - Stainless Steel

- ATEX certification for gas and dust explosion proof
- Same electrical performance as ACURO industry
- Protection class up to IP67
- Diameter only 70 mm
- Robust design
- Also available with stainless steel housing (AX 71 - Profibus)
- Resolution up to 26 Bit (14 Bit ST, 12 Bit MT)
- Applications: enamelling production line, petro chemistry, bottling machines, mixers, silo works, mills



**EX-CLASSIFICATION**

The absolute shaft encoder line ACURO is available in explosion proof design with explosion proof enclosure "d" under AX 70 and AX 71 (stainless steel). The PTB has assured with the Declaration of Conformity that the AX 70 / 71 meets the requirements of safety and health according to EN 50014 and EN 50018. Therefore it is approved in explosive areas, code "Ex II 2 G/D E Ex d II C T4/T6 IP65/ IP66 135°C resp. 85°C". For applications under tough environmental conditions and food industry the stainless steel version AX 71 is available.

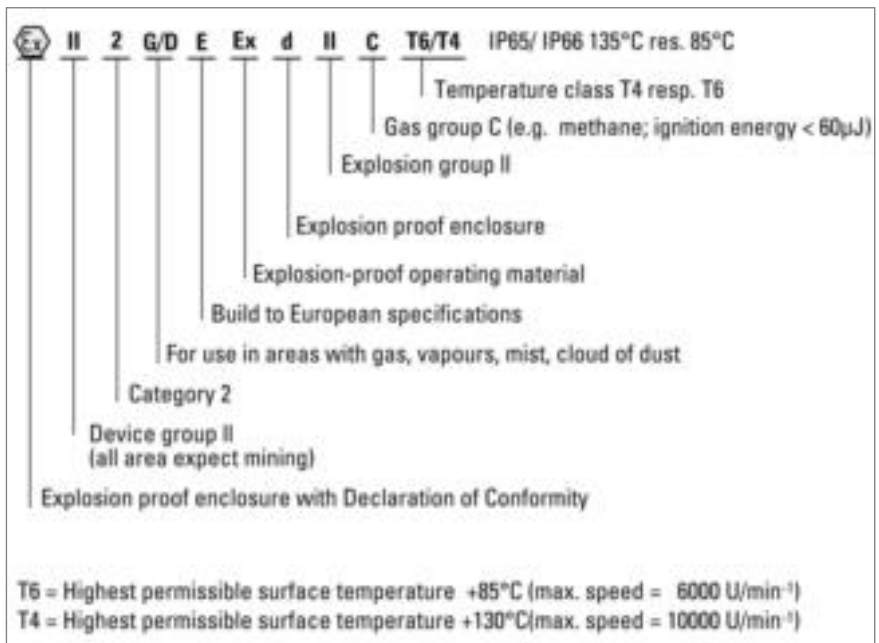

**TECHNICAL DATA**  
mechanical

Housing diameter	70 mm
Shaft diameter	10 mm (Solid shaft)

## Absolute

## Profibus

### TECHNICAL DATA mechanical (continued)

Flange (Mounting of housing)	Clamping flange
Protection class shaft input (EN 60529) <sup>1</sup>	T4: IP64 or IP67 T6: IP64
Protection class housing (EN 60529)	T4: IP65 or IP67 T6: IP65
Shaft load axial / radial	40 N / 100 N
Max. speed	T4: max. 10 000 rpm T6: max. 6000 rpm
Torque	≤ 1 Ncm
Moment of inertia	approx. 20 gcm <sup>2</sup>
Vibration resistance (DIN EN 60068-2-6)	100 m/s <sup>2</sup> (10 ... 500 Hz)
Shock resistance (DIN EN 60068-2-27)	1000 m/s <sup>2</sup> (6 ms)
Ambient temperature	T4: -40 °C ... +60 °C T6: -40 °C ... +40 °C
Storage temperature	-25 °C ... +85 °C
Material shaft	Stainless Steel
Material housing	AX 70: Aluminum AX 71: Stainless Steel
Weight	AX 70: approx. 1.4 kg AX 71: approx. 4.8 kg
Connection	Cable, axial

<sup>1</sup> No dust explosion-proof (D) for IP64

### TECHNICAL DATA electrical

Supply voltage	DC 10-30 V
Max. current w/o load	220 mA (ST), 250 mA (MT)
Resolution singleturn	10 - 14 Bit
Resolution multiturn	12 Bit
Output code	Binary
Profile/ protocol	Profibus DP with encoder profile class C2 (parameterizable)
Parametrization	Resolution, Preset, Direction
Integrated special functions	Speed, Acceleration, Operating time
Baud rate	is automatically set within a range of 9.6 KBaud through 12 MBaud
Device address	set via Bus
Bus termination resistor	external mounting

**Absolute**

**Profibus**

**ELECTRICAL CONNECTIONS**  
Cable

Color	Profibus
yellow	B in
green	A in
pink	B out
grey	A out
blue	GND1 (M5V <sup>1</sup> )
brown	VCC1 (P5V <sup>1</sup> )
white 0.5 mm	DC 10 ... 30 V
brown 0.5 mm	0 V
Screen	Screen connected to encoder housing

<sup>1</sup> used for power supply for an external bus termination resistor

**DIMENSIONED DRAWINGS**

see chapter "Dimensioned drawings AX 70 / AX 71", starting page 253

**ORDERING INFORMATION**

Type	Resolution	Supply voltage	Flange, Protection, Shaft <sup>1,2</sup>	Interface	Connection
<input type="checkbox"/>	<input type="text"/>	<input type="checkbox"/>	<input type="text"/>	<input type="checkbox"/>	<input type="checkbox"/>
<b>AX70</b> <b>AX71</b>	<b>0010</b> 10 Bit ST <b>0012</b> 12 Bit ST <b>0013</b> 13 Bit ST <b>0014</b> 14 Bit ST <b>1212</b> 12 Bit MT + 12 Bit ST <b>1213</b> 12 Bit MT + 13 Bit ST <b>1214</b> 12 Bit MT + 14 Bit ST	<b>E</b> DC 10 - 30 V	<b>K.42</b> Clamping, IP64, 10 mm <b>K.72</b> Clamping, IP67, 10 mm	<b>DP</b> Profibus	<b>A</b> Cable, axial

<sup>1</sup> Dust explosion-proof certification (D) only for IP67

<sup>2</sup> IP67 only with temperature class T4

**ORDERING INFORMATION**  
Selection of cable length

Versions with cable outlet (connection A, B, E or F) are available with various lengths of cable. To order your desired cable length, please add the respective code to the end of your ordering code. Further cable lengths on request.

Code	Cable length
-F0 / without code	5 m
-K0	10 m
-P0	15 m
-U0	20 m
-V0	25 m

**ACCESSORIES**

see chapter "Accessories", starting page 322



**Absolute**

**CANopen**



Version AX 70 - Aluminium



Version AX 71 - Stainless Steel

- ATEX certification for gas and dust explosion proof
- Same electrical performance as ACURO industry
- Protection class up to IP67
- Diameter only 70 mm
- Robust design
- Also available with stainless steel housing (AX 71 - CANopen)
- Resolution up to 26 Bit (14 Bit ST, 12 Bit MT)
- Applications: enamelling production line, petro chemistry, bottling machines, mixers, silo works, mills



**EX-CLASSIFICATION**

The absolute shaft encoder line ACURO is available in explosion proof design with explosion proof enclosure "d" under AX 70 and AX 71 (stainless steel). The PTB has assured with the Declaration of Conformity that the AX 70 / 71 meets the requirements of safety and health according to EN 50014 and EN 50018. Therefore it is approved in explosive areas, code "Ex II 2 G/D E Ex d II C T4/T6 IP65/ IP66 135°C resp. 85°C". For applications under tough environmental conditions and food industry the stainless steel version AX 71 is available.

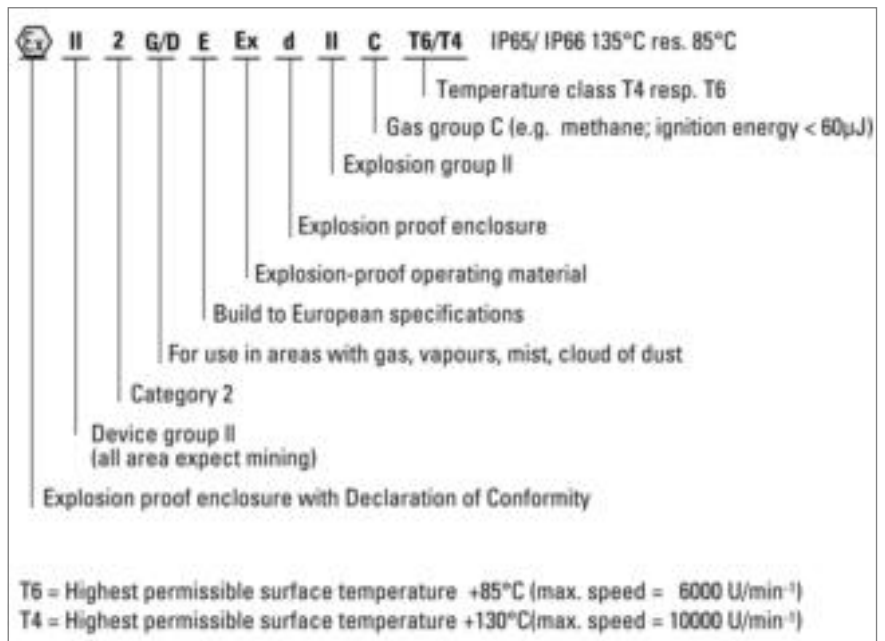

**TECHNICAL DATA**  
mechanical

Housing diameter	70 mm
Shaft diameter	10 mm (Solid shaft)

## Absolute

## CANopen

### TECHNICAL DATA mechanical (continued)

Flange (Mounting of housing)	Clamping flange
Protection class shaft input (EN 60529) <sup>1</sup>	T4: IP64 or IP67 T6: IP64
Protection class housing (EN 60529)	T4: IP65 or IP67 T6: IP65
Shaft load axial / radial	40 N / 100 N
Max. speed	T4: max. 10 000 rpm T6: max. 6000 rpm
Torque	≤ 1 Ncm
Moment of inertia	approx. 20 gcm <sup>2</sup>
Vibration resistance (DIN EN 60068-2-6)	100 m/s <sup>2</sup> (10 ... 500 Hz)
Shock resistance (DIN EN 60068-2-27)	1000 m/s <sup>2</sup> (6 ms)
Ambient temperature	T4: -40 °C ... +60 °C T6: -40 °C ... +40 °C
Storage temperature	-25 °C ... +85 °C
Material shaft	Stainless Steel
Material housing	AX 70: Aluminum AX 71: Stainless Steel
Weight	AX 70: approx. 1.4 kg AX 71: approx. 4.8 kg
Connection	Cable, axial

<sup>1</sup> No dust explosion-proof (D) for IP64

### TECHNICAL DATA electrical

Supply voltage	DC 10-30 V
Max. current w/o load	250 mA (ST / MT)
Resolution singleturn	10 - 14 Bit
Resolution multiturn	12 Bit
Output code	Binary
Profile/ protocol	CANopen according to DS 301 with profile DSP 406, programmable encoder according class C2
Parametrization	Resolution, Preset, Offset, Direction
Integrated special functions	Speed, Acceleration, Rotery axis, Limit values, Operating time
Bus termination resistor	external mounting

### ELECTRICAL CONNECTIONS Cable

Colour	CANopen
yellow	CAN in+
green	CAN in-
pink	CAN out+
grey	CAN out-
blue	CAN GND in
black	CAN GND out
white 0.5 mm	UB in
brown 0.5 mm	0 V in
Screen	Screen connected with encoder housing

**Absolute**

**CANopen**

**DIMENSIONED DRAWINGS**

see chapter "Dimensioned drawings AX 70 / AX 71", starting page 253

**ORDERING INFORMATION**

Type	Resolution	Supply voltage	Flange, Protection, Shaft <sup>1,2</sup>	Interface	Connection
<input type="checkbox"/>	<input type="text"/>	<input type="checkbox"/>	<input type="text"/>	<input type="checkbox"/>	<input type="checkbox"/>
<b>AX70</b> <b>AX71</b>	<b>0010</b> 10 Bit ST <b>0012</b> 12 Bit ST <b>0013</b> 13 Bit ST <b>0014</b> 14 Bit ST <b>1212</b> 12 Bit MT + 12 Bit ST <b>1213</b> 12 Bit MT + 13 Bit ST <b>1214</b> 12 Bit MT + 14 Bit ST	<b>E</b> DC 10 - 30 V	<b>K.42</b> Clamping, IP64, 10 mm <b>K.72</b> Clamping, IP67, 10 mm	<b>OL</b> CANopen	<b>A</b> Cable, axial

<sup>1</sup> Dust explosion-proof certification (D) only for IP67

<sup>2</sup> IP67 only with temperature class T4

**ORDERING INFORMATION**

**Selection of cable length**

Versions with cable outlet (connection A, B, E or F) are available with various lengths of cable. To order your desired cable length, please add the respective code to the end of your ordering code. Further cable lengths on request.

Code	Cable length
-F0 / without code	5 m
-K0	10 m
-P0	15 m
-U0	20 m
-V0	25 m

**ACCESSORIES**

see chapter "Accessories", starting page 322

**Absolute**

**SSI programmable**



Version AX 70 - Aluminium



Version AX 71 - Stainless Steel

- ATEX certification for gas and dust explosion proof
- Same electrical performance as ACURO industry
- Protection class up to IP67
- Diameter only 70 mm
- Robust design
- Also available with stainless steel housing (AX 71 - SSI-P)
- Resolution up to 29 Bit (17 Bit ST, 12 Bit MT)
- Applications: enamelling production line, petro chemistry, bottling machines, mixers, silo works, mills



**EX-CLASSIFICATION**

The absolute shaft encoder line ACURO is available in explosion proof design with explosion proof enclosure "d" under AX 70 and AX 71 (stainless steel).  
 The PTB has assured with the Declaration of Conformity that the AX 70 / 71 meets the requirements of safety and health according to EN 50014 and EN 50018. Therefore it is approved in explosive areas, code "Ex II 2 G/D E Ex d II C T4/T6 IP65/ IP66 135°C resp. 85°C".  
 For applications under tough environmental conditions and food industry the stainless steel version AX 71 is available.

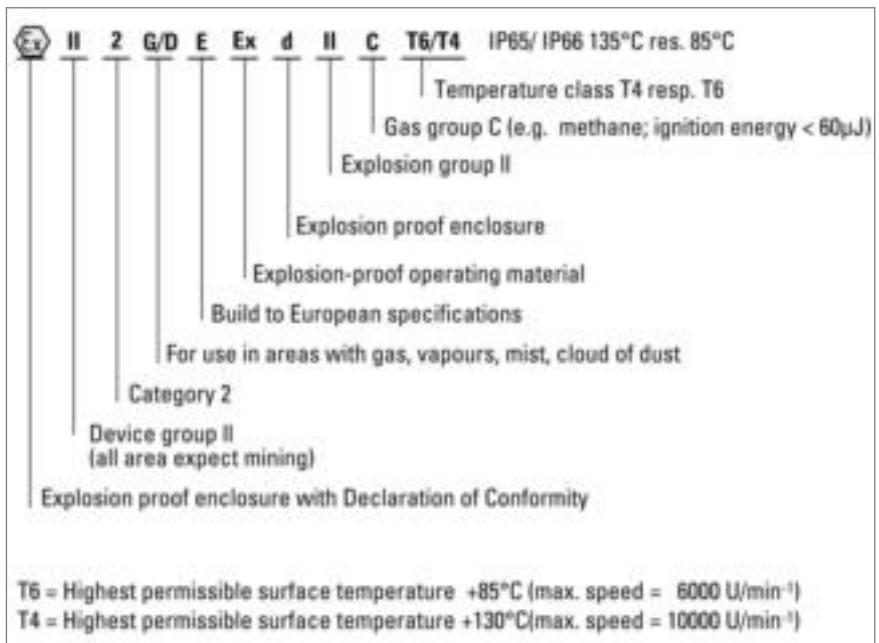

**TECHNICAL DATA**  
mechanical

Housing diameter	70 mm
Shaft diameter	10 mm (Solid shaft)

## Absolute

## SSI programmable

### TECHNICAL DATA mechanical (continued)

Flange (Mounting of housing)	Clamping flange
Protection class shaft input (EN 60529) <sup>1</sup>	T4: IP64 or IP67 T6: IP64
Protection class housing (EN 60529)	T4: IP65 or IP67 T6: IP65
Shaft load axial / radial	40 N / 100 N
Max. speed	T4: max. 10 000 rpm T6: max. 6000 rpm
Torque	≤ 1 Ncm
Moment of inertia	approx. 20 gcm <sup>2</sup>
Vibration resistance (DIN EN 60068-2-6)	100 m/s <sup>2</sup> (10 ... 500 Hz)
Shock resistance (DIN EN 60068-2-27)	1000 m/s <sup>2</sup> (6 ms)
Ambient temperature	T4: -40 °C ... +60 °C T6: -40 °C ... +40 °C
Storage temperature	-25 °C ... +85 °C
Material shaft	Stainless Steel
Material housing	AX 70: Aluminum AX 71: Stainless Steel
Weight	AX 70: approx. 1.4 kg AX 71: approx. 4.8 kg
Connection	Cable, axial

<sup>1</sup> No dust explosion-proof (D) for IP64

### TECHNICAL DATA electrical

Supply voltage	DC 10-30 V
Max. current w/o load	250 mA (ST / MT)
Resolution singleturn	10 - 17 Bit
Resolution multiturn	12 Bit
Output code	Binary, Gray
Drives	Clock and Data / RS422
Parametrization	Resolution, Code type, Direction, Output format, Warning, Alarm, Preset values
Control inputs	Direction, Preset 1, Preset 2
Alarm output	Alarm bit

<sup>1</sup> Programmable with WIN SSI

### RECOMMENDED DATA TRANSFER RATE bei SSI

The max. data transfer rate depends on the cable length. For Clock /  $\overline{\text{Clock}}$  and Data /  $\overline{\text{Data}}$  please use twisted pairs. Use shielded cable.

Cable length	Frequency
< 50 m	< 400 kHz
< 100 m	< 300 kHz
< 200 m	< 200 kHz
< 400 m	< 100 kHz

**Absolute**

**SSI programmable**

**ELECTRICAL CONNECTIONS**  
Cable

Color	No.	SSI programmable
white 0.14 mm	6	RS232 RxD
brown 0.14 mm	5	RS232 TxD
green	10	Clock
yellow	9	Clock
grey	8	Data
pink	7	Data
blue	3	Direction
black	4	0 V signal output
red	1	Preset 1
violet	2	Preset 2
brown 0.5 mm	11	0 V supply voltage
white 0.5 mm	12	DC 10 ... 30 V
Screen		Screen connected to encoder housing

**DIMENSIONED DRAWINGS**

see chapter "Dimensioned drawings AX 70 / AX 71", starting page 253

**ORDERING INFORMATION**

Type	Resolution	Supply voltage	Flange, Protection, Shaft <sup>1,2</sup>	Interface	Connection
<input type="checkbox"/>	<input type="text"/>	<input type="checkbox"/>	<input type="text"/>	<input type="checkbox"/>	<input type="checkbox"/>
<b>AX70</b> <b>AX71</b>	<b>0010</b> 10 Bit ST <b>0012</b> 12 Bit ST <b>0013</b> 13 Bit ST <b>0014</b> 14 Bit ST <b>0017</b> 17 Bit ST <b>1212</b> 12 Bit MT + 12 Bit ST <b>1213</b> 12 Bit MT + 13 Bit ST <b>1214</b> 12 Bit MT + 14 Bit ST <b>1217</b> 12 Bit MT + 17 Bit ST higher resolution on request	<b>E</b> DC 10 - 30 V	<b>K.42</b> Clamping, IP64, 10 mm <b>K.72</b> Clamping, IP67, 10 mm	<b>SP</b> SSI pro-grammable	<b>A</b> Cable, axial

<sup>1</sup> Dust explosion-proof certification (D) only for IP67

<sup>2</sup> IP67 only with temperature class T4

**ORDERING INFORMATION**  
Selection of cable length

Versions with cable outlet (connection A, B, E or F) are available with various lengths of cable. To order your desired cable length, please add the respective code to the end of your ordering code. Further cable lengths on request.

Code	Cable length
-F0 / without code	5 m
-K0	10 m
-P0	15 m
-U0	20 m
-V0	25 m

**ACCESSORIES**

see chapter "Accessories", starting page 322

DIMENSIONED DRAWINGS

SSI

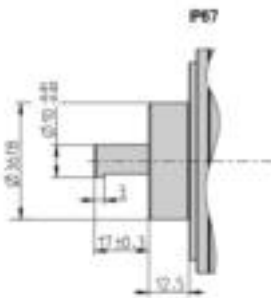
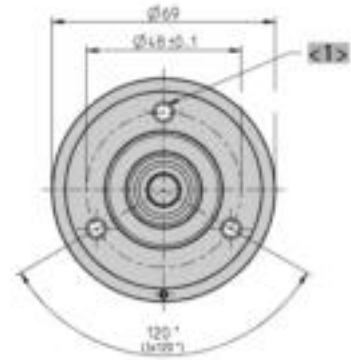
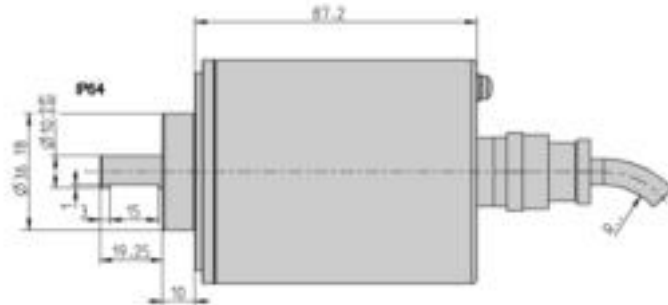

<1> mounting thread M6x12  
Cable bending radius R for flexible installation  $\geq 150$  mm

Cable bending radius R for fixed installation  $\geq 40$  mm

Dimensions in mm

**DIMENSIONED DRAWINGS (continued)**

**SSI-P, Profibus, CANopen**

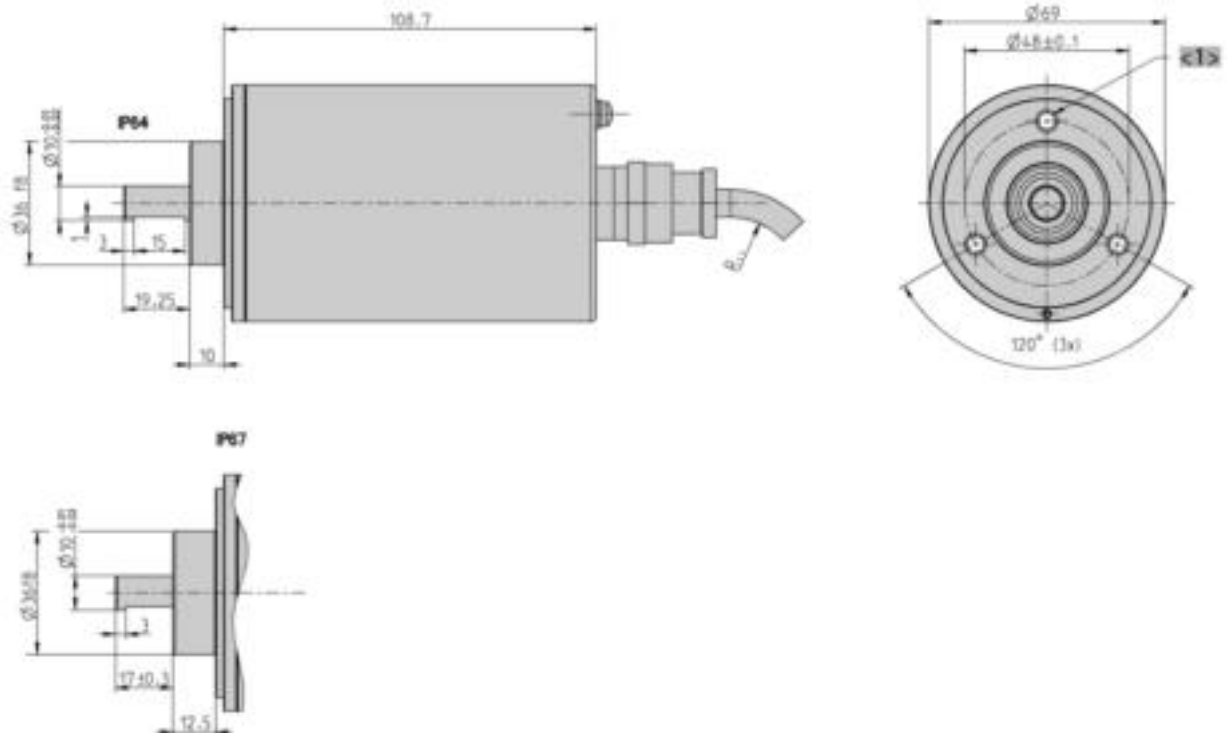

<1> mounting thread M6x12  
 Cable bending radius R for flexible installation  $\geq 150$  mm

Cable bending radius R for fixed installation  $\geq 40$  mm

Dimensions in mm



## Light Duty Types

If you are looking for a compact, but high-resolution incremental encoder, then our light duty encoder line offers a broad selection to you.

With up to 3600 pulses per turn Hengstler's light duty encoder line is one of the most compact and ones in its class.

Despite its small frame size the encoders have two integrated precision ball bearings, which stand for a long life at high speed (up to 10.0000 rpm). The electrical features are in no way inferior to the mechanical ones: The encoders are equipped with state-of-the-art optoelectric technology, which increases the encoder's reliability by its high immunity to interference. It is also provided with monitoring electronics which in the event of failure fires an alarm output. If, for example, over temperature prevails, or the voltage range is fallen below the specified minimum, the alarm output will return a signal.

### Examples of applications for Light Duty Encoders:

- laboratory equipment
- crimping machines
- tampon printing machines
- miniature grinding machines
- FHP motors
- labelling machines
- plotters
- graphic machines
- textile machinery

## Incremental



- Provides digital control inputs from operators's panel
- Bidirectional squarewave signal outputs
- Up to 512 increments
- Continuous and reversible rotation
- Non-contacting
- Operating temperature -40 ... 100 °C



### NUMBER OF PULSES

100 ... 512

### TECHNICAL DATA mechanical

Housing diameter	PC 9: 22 mm PC 9S: 22.86 mm
Shaft diameter	1 1/8" / 0.25
Shaft load axial / radial	1/8" shaft: 4 N / 27 N 1/4" shaft: 4 N / 4 N
Moment of inertia	approx. 0.2 gcm <sup>2</sup>
Operating temperature	-40 °C ... +100 °C
Storage temperature	-50 °C ... +125 °C
Relative humidity	90 %, non-condensing
Connection	PC 9: 10 pole header (Accessory: 30 cm ribbon cable with connector, ordering code CA0040012) PC 9S: 5 pole header (Accessory: 30 cm ribbon cable with connector, ordering code CA0050012)
Recommended mating connector	PC 9: Thomas & Betts, ordering code 622-1030 (on request) PC 9S: AMP, ordering code 103675-4 (on request)

### TECHNICAL DATA electrical

Standby current	50 µA
Code	Incremental, optical
Max. pulse frequency	200 kHz
Index pulse width (N)	90° ± 36° electrical
Phasing	90° ± 18° electrical
Symmetry	180° ± 18° electrical
Number of pulses	100 ... 512
Output signals	min. 2.5 V high (VOH), max. 0.5 V low (VOL)
Output current	PC 9: 3 mA sink/source (25 °C), 2 mA (100 °C) PC 9S: 6 mA sink/source (25 °C), 4 mA (100 °C)
Pulse shape	Square wave
Pulse duty factor	1:1

Incremental

OUTPUT WAVEFORMS (only PC 9)

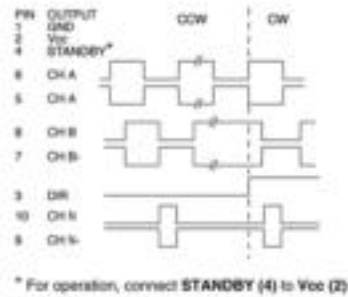

Figure 1: Code 2 (Output) = 01

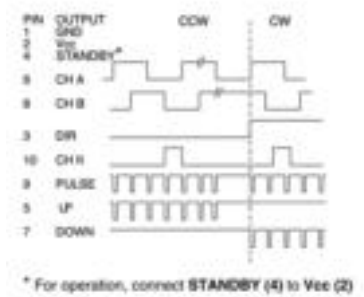
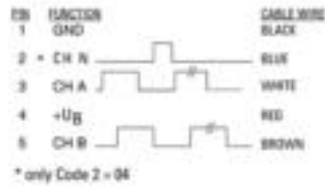

Figure 2: Code 2 (Output) = 02

ELECTRICAL CONNECTIONS  
OUTPUT WAVEFORMS (only PC 9S)



\* only code 2 (output) = 04

Figure 3: Code 2 (Output) = 03/04

CONNECTION (only PC 9)

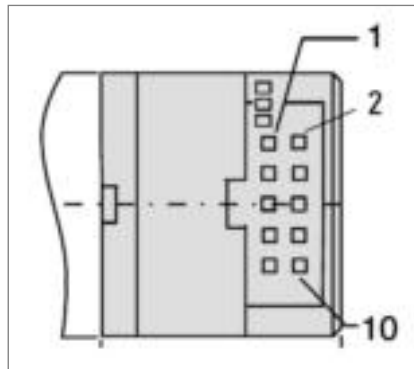

CONNECTION (only PC 9S)

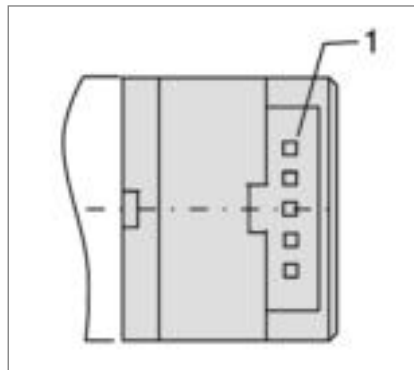

## Incremental

### DIMENSIONED DRAWINGS

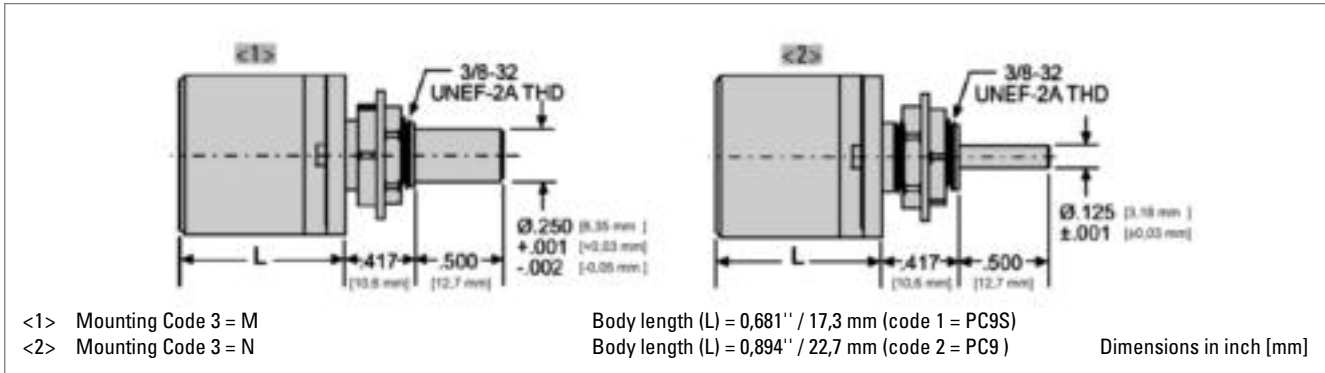

### ORDERING INFORMATION

Type	Number of pulses	Code 2: Output	Mounting
<input type="checkbox"/>	<input type="checkbox"/>	<input type="checkbox"/>	<input type="checkbox"/>
<b>PC9</b> <b>PC9S</b>	<b>0100</b> <b>0144</b> <b>0200</b> <b>0256</b> <b>0300</b> <b>0360</b> <b>0500</b> <b>0512</b>	<b>01</b> see Fig. 1 (PC 9) <b>02</b> see Fig. 2 (PC 9) <b>03</b> see Fig. 3 (without index) (PC 9S) <b>04</b> see Fig. 3 (PC 9S)	<b>M</b> 1/4" shaft, sleeve bearings <b>N</b> 1/8" shaft, ball bearings

## Incremental



## NUMBER OF PULSES

- Replacement for type Typ RIS and RI 31
- The economical encoder for small appliances
- High efficiency by means of ball bearing
- Small torque
- Applications: laboratory equipment, training equipment, crimping machines, tampon printing machines, miniature grinding machines



5 / 10 / 20 / 25 / 30 / 50 / 60 / 100 / 120 / 128 / 200 / 250 / 256 / 288 / 300 / 360 / 400 / 500 / 512 / 600 / 720 / 900 / 1000 / 1024 / 1250 / 1500

Other number of pulses on request

**TECHNICAL DATA**  
 mechanical

Housing diameter	30 mm
Shaft diameter	5 mm / 6 mm (Solid shaft)
Flange (Mounting of housing)	Pilot flange
Protection class shaft input (EN 60529)	IP40
Protection class housing (EN 60529)	IP50
Shaft load axial / radial	5 N / 10 N
Max. speed	max. 6000 rpm
Torque	≤ 0.05 Ncm
Vibration resistance (DIN EN 60068-2-6)	100 m/s <sup>2</sup> (10 ... 2000 Hz)
Shock resistance (DIN EN 60068-2-27)	1000 m/s <sup>2</sup> (6 ms)
Operating temperature	-10 °C ... +60 °C
Storage temperature	-25 °C ... +85 °C
Material shaft	Aluminum
Material housing	Plastic
Weight	approx. 50 g
Connection	Cable, axial or radial

**TECHNICAL DATA**  
 electrical

General design	as per DIN VDE 0160, protection class III, contamination level 2, overvoltage class II
Supply voltage <sup>1</sup>	Push-pull (D): DC 5 V ±10 % Push-pull (K): ± 10% DC 5 V or DC 10 - 30 V
Max. current w/o load	40 mA (DC 5 V), 60 mA (DC 10 V), 30 mA (DC 24 V)
Max. pulse frequency	DC 5 V: 300 kHz DC 10 - 30 V: 200 kHz
Standard output versions <sup>2,3</sup>	Push-pull (K): A, B, N, $\overline{\text{Alarm}}$ Push-pull 5V, ± 30 mA (D): A, B, N, $\overline{\text{Alarm}}$
Pulse width error	± max. 25° electrical
Number of pulses	5 ... 1500
Alarm output	NPN-O.C., max. 5 mA
Pulse shape	Square wave
Pulse duty factor	1:1

## Incremental

### TECHNICAL DATA electrical (continued)

- <sup>1</sup> With push-pull (K): pole protection
- <sup>2</sup> Output code "K": short-circuit-proof
- <sup>3</sup> Output description and technical data see chapter "Technical basics"

### ELECTRICAL CONNECTIONS Cable

Description (push-pull)	Lead $\varnothing$ mm <sup>2</sup>	Colour
DC 5 V/ 10 - 30 V	0.5	red
Channel A	0.14	white
Channel B	0.14	green
Channel N	0.14	yellow
GND	0.5	black
Alarm	0.14	yellow/black

### DIMENSIONED DRAWINGS

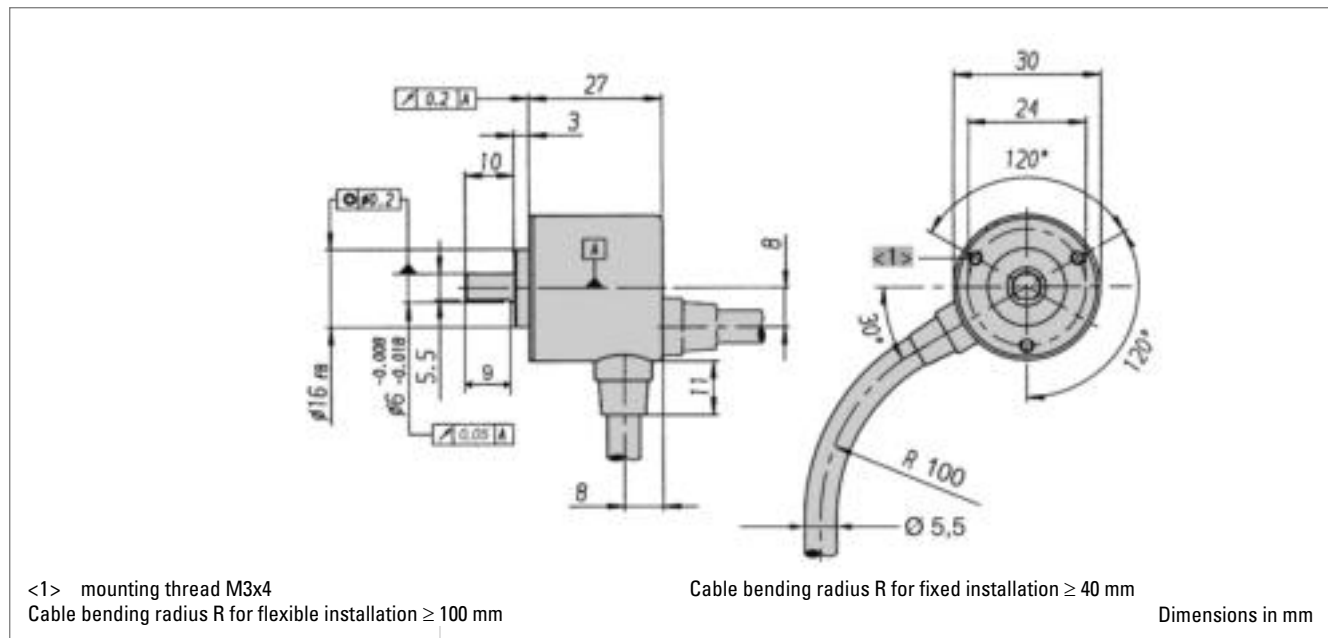

### ORDERING INFORMATION

Type	Number of pulses	Supply voltage <sup>1</sup>	Flange, Protection, Shaft <sup>2,3</sup>	Output <sup>4,5</sup>	Connection
<input type="checkbox"/>	<input type="checkbox"/>	<input type="checkbox"/>	<input type="checkbox"/>	<input type="checkbox"/>	<input type="checkbox"/>
<b>RI32</b>	<b>5 ... 1500</b>	<b>A</b> DC 5 V <b>E</b> DC 10 - 30 V	<b>R.14</b> Pilot, IP40, 5 mm <b>R.11</b> Pilot, IP40, 6 mm	<b>K</b> Push-pull <b>D</b> Push-pull 5V, $\pm$ 30 mA	<b>A</b> Cable, axial <b>B</b> Cable, radial

- <sup>1</sup> DC 10 - 30 V: only with output "K" available
- <sup>2</sup> R.11: flattened, see dimensional drawing
- <sup>3</sup> R.14: not flattened
- <sup>4</sup> Output code "K":  $\pm$ 10 mA at DC 5 V,  $\pm$ 30 mA at DC 10 - 30 V
- <sup>5</sup> Output code "K": short-circuit-proof

## Incremental

### ORDERING INFORMATION

Selection of cable length

Versions with cable outlet (connection A, B, E or F) are available with various lengths of cable. To order your desired cable length, please add the respective code to the end of your ordering code. Further cable lengths on request.

Code	Cable length
without code	1.5 m
-D0	3 m
-F0	5 m
-K0	10 m
-P0	15 m
-U0	20 m
-V0	25 m

### ACCESSORIES

see chapter "Accessories", starting page 322

## Incremental



### NUMBER OF PULSES

- Replacement for type RI 39
- Encoder for universal installation by means of front/back panel mounting
- High efficiency by means of ball bearing
- Small torque
- Applications: FHP motors, laboratory equipment, labelling machines, plotters, length measuring machines



5 / 10 / 20 / 25 / 28 / 32 / 50 / 60 / 72 / 100 / 128 / 144 / 200 / 250 / 256 / 288 / 300 / 360 / 400 / 500 / 512 / 600 / 720 / 900 / 1000 / 1024

Other number of pulses on request

### TECHNICAL DATA mechanical

Housing diameter	39 mm
Shaft diameter	6 mm (Solid shaft)
Flange (Mounting of housing)	Square flange
Protection class shaft input (EN 60529)	IP40
Protection class housing (EN 60529)	IP50
Shaft load axial / radial	5 N / 10 N
Max. speed	max. 10 000 rpm
Torque	≤ 0.2 Ncm
Vibration resistance (DIN EN 60068-2-6)	100 m/s <sup>2</sup> (10 ... 2000 Hz)
Shock resistance (DIN EN 60068-2-27)	1000 m/s <sup>2</sup> (6 ms)
Operating temperature	-10 °C ... +60 °C
Storage temperature	-25 °C ... +85 °C
Material housing	Glass fiber-reinforced plastic
Weight	approx. 60 g
Connection	Cable, radial

### TECHNICAL DATA electrical

General design	as per DIN VDE 0160, protection class III, contamination level 2, overvoltage class II
Supply voltage <sup>1</sup>	Push-pull (D): DC 5 V ± 10 % Push-pull (K): ± 10% DC 5 V or DC 10 - 30 V
Max. current w/o load	40 mA (DC 5 V), 60 mA (DC 10 V), 30 mA (DC 24 V)
Max. pulse frequency	DC 5 V: 300 kHz DC 10 - 30 V: 200 kHz
Standard output versions <sup>2,3</sup>	Push-pull (K): A, B, N, $\overline{\text{Alarm}}$ Push-pull 5V, ± 30 mA (D): A, B, N, $\overline{\text{Alarm}}$
Pulse width error	± max. 25° electrical
Number of pulses	5 ... 1024
Alarm output	NPN-O.C., max. 5 mA
Pulse shape	Square wave
Pulse duty factor	1:1



## Incremental

### TECHNICAL DATA electrical (continued)

- <sup>1</sup> With push-pull (K): pole protection
- <sup>2</sup> Output code "K": short-circuit-proof
- <sup>3</sup> Output description and technical data see chapter "Technical basics"

### ELECTRICAL CONNECTIONS Cable

Description (push-pull)	Lead Ø mm <sup>2</sup>	Colour
DC 5 V/ 10 - 30 V	0.5	red
Channel A	0.14	white
Channel B	0.14	green
Channel N	0.14	yellow
GND	0.5	black
Alarm	0.14	yellow/black

### DIMENSIONED DRAWINGS

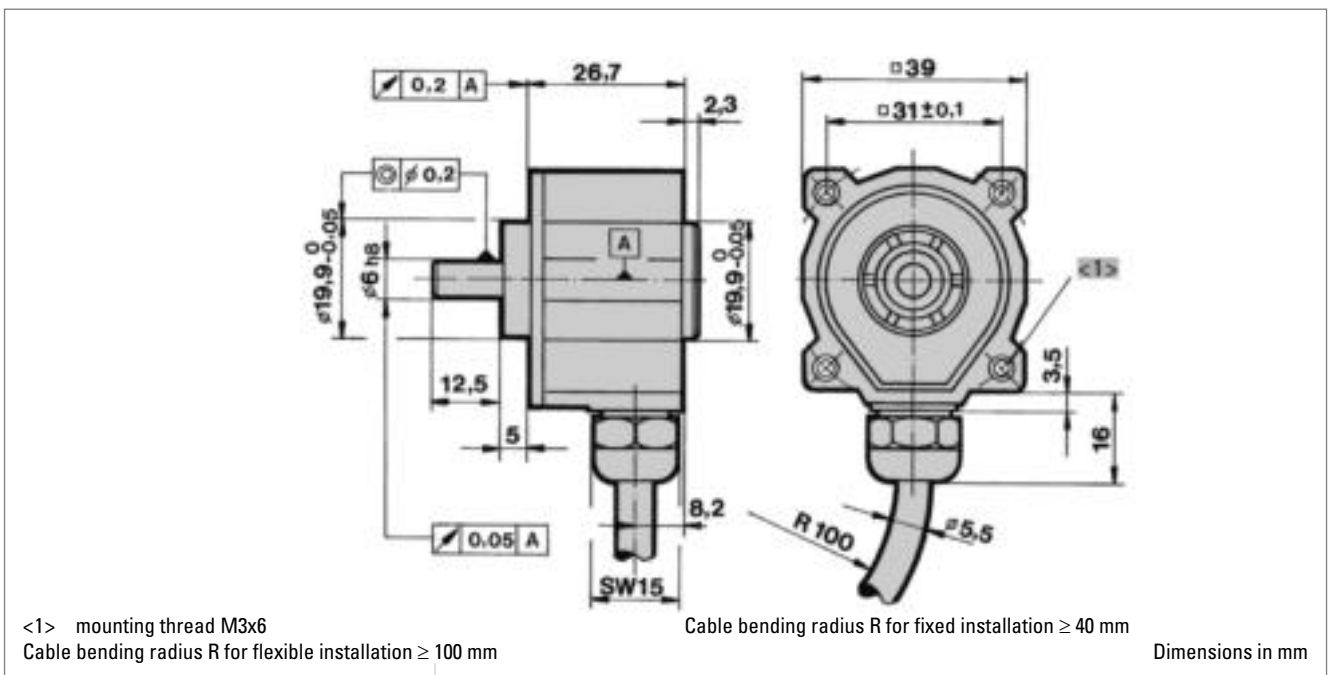

### ORDERING INFORMATION

Type	Number of pulses	Supply voltage <sup>1</sup>	Flange, Protection, Shaft	Output <sup>2,3</sup>	Connection
<input type="checkbox"/>	<input type="checkbox"/>	<input type="checkbox"/>	<input type="checkbox"/>	<input type="checkbox"/>	<input type="checkbox"/>
<b>RI38</b>	<b>5 ... 1024</b>	<b>A DC 5 V</b> <b>E DC 10 - 30 V</b>	<b>0.11</b> Square, IP40, 6 mm	<b>K</b> Push-pull <b>D</b> Push-pull 5V, ± 30 mA	<b>B</b> Cable, radial

<sup>1</sup> DC 10 - 30 V: only with output "K" available

<sup>2</sup> Output code "K": ±10 mA at DC 5 V, ±30 mA at DC 10 - 30 V

<sup>3</sup> Output code "K": short-circuit-proof

**ORDERING INFORMATION**  
**Selection of cable length****Incremental**

Versions with cable outlet (connection A, B, E or F) are available with various lengths of cable. To order your desired cable length, please add the respective code to the end of your ordering code. Further cable lengths on request.

<b>Code</b>	<b>Cable length</b>
without code	1.5 m
-D0	3 m
-F0	5 m
-K0	10 m
-P0	15 m
-U0	20 m
-V0	25 m

**ACCESSORIES**

see chapter "Accessories", starting page 322

## Incremental



## NUMBER OF PULSES

- Replacement for type RIM
- Economical miniature encoder
- Up to 14,400 steps with 3,600 pulses
- High mechanical efficiency
- Applications: wood working machines, FHP motors, graphic machines, table robots



5 / 10 / 20 / 25 / 28 / 32 / 50 / 60 / 72 / 100 / 128 / 144 / 200 / 250 / 256 / 288 / 300 / 360 / 400 / 500 / 512 / 600 / 720 / 900 / 1000 / 1024 / 1250 / 1500 / 2000 / 2048 / 2500 / 3000 / 3600  
Other number of pulses on request

TECHNICAL DATA  
mechanical

Housing diameter	40 mm
Shaft diameter	6 mm (Solid shaft)
Flange (Mounting of housing)	Pilot flange
Protection class shaft input (EN 60529)	IP40
Protection class housing (EN 60529)	IP50
Shaft load axial / radial	5 N / 10 N
Max. speed	max. 10 000 rpm
Torque	≤ 0.2 Ncm
Vibration resistance (DIN EN 60068-2-6)	100 m/s <sup>2</sup> (10 ... 2000 Hz)
Shock resistance (DIN EN 60068-2-27)	1000 m/s <sup>2</sup> (6 ms)
Operating temperature	-10 °C ... +70 °C
Storage temperature	-25 °C ... +85 °C
Material housing	Aluminum
Weight	approx. 60 g
Connection	Cable, radial

TECHNICAL DATA  
electrical

General design	as per DIN VDE 0160, protection class III, contamination level 2, overvoltage class II
Supply voltage <sup>1</sup>	Push-pull (D): DC 5 V ±10 % Push-pull (K): ± 10% DC 5 V or DC 10 - 30 V
Max. current w/o load	40 mA (DC 5 V), 60 mA (DC 10 V), 30 mA (DC 24 V)
Max. pulse frequency	DC 5 V: 300 kHz DC 10 - 30 V: 200 kHz
Standard output versions <sup>2,3</sup>	Push-pull (K): A, B, N, $\overline{\text{Alarm}}$ Push-pull 5V, ± 30 mA (D): A, B, N, $\overline{\text{Alarm}}$
Pulse width error	± max. 25° electrical
Number of pulses	5 ... 3600
Alarm output	NPN-O.C., max. 5 mA
Pulse shape	Square wave
Pulse duty factor	1:1

## Incremental

### TECHNICAL DATA electrical (continued)

- <sup>1</sup> With push-pull (K): pole protection
- <sup>2</sup> Output code "K": short-circuit-proof
- <sup>3</sup> Output description and technical data see chapter "Technical basics"

### ELECTRICAL CONNECTIONS Cable

Description (push-pull)	Lead Ø mm <sup>2</sup>	Colour
DC 5 V/10 - 30 V	0.5	red
Channel A	0.14	white
Channel B	0.14	green
Channel N	0.14	yellow
GND	0.5	black
Alarm	0.14	yellow/black
screen <sup>1</sup>		screen <sup>1</sup>

<sup>1</sup> not connected with encoder housing

### DIMENSIONED DRAWINGS

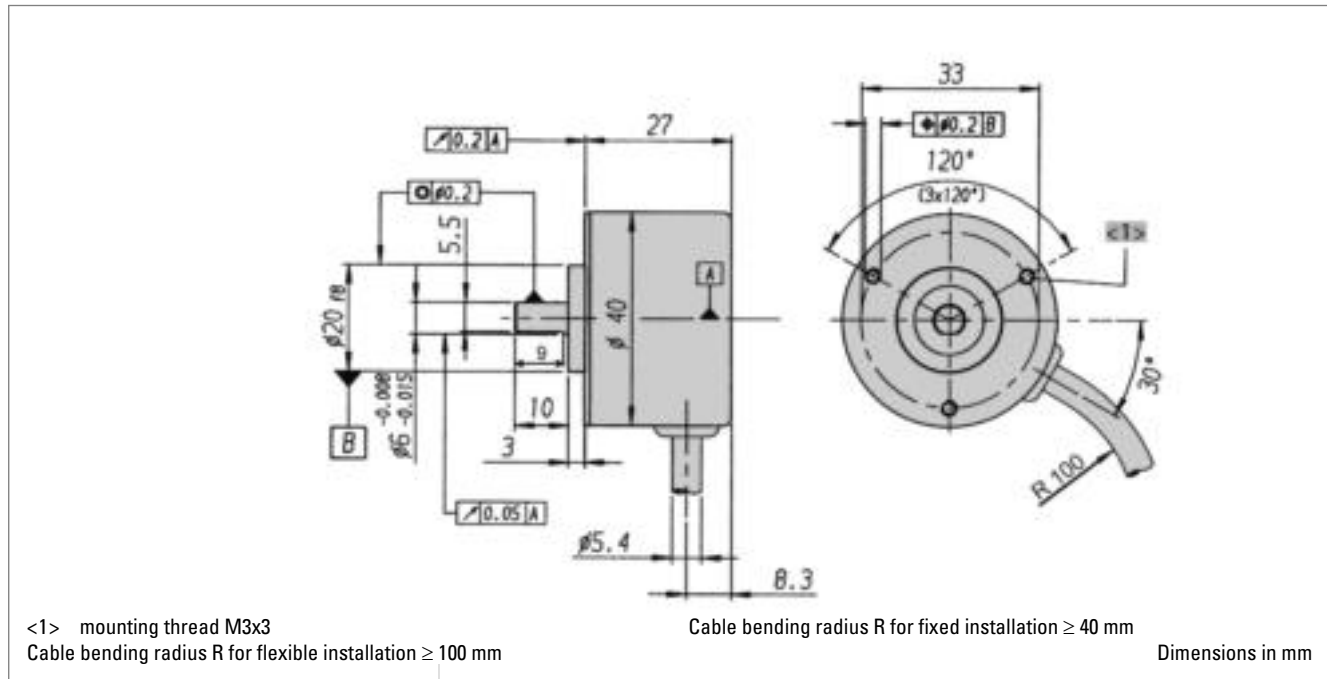

### ORDERING INFORMATION

Type	Number of pulses	Supply voltage <sup>1</sup>	Flange, Protection, Shaft	Output <sup>2,3</sup>	Connection
<input type="checkbox"/>	<input type="checkbox"/>	<input type="checkbox"/>	<input type="checkbox"/>	<input type="checkbox"/>	<input type="checkbox"/>
<b>RI41</b>	<b>5 ... 3600</b>	<b>A DC 5 V</b> <b>E DC 10 - 30 V</b>	<b>R.11</b> Pilot, IP40, 6 mm	<b>K</b> Push-pull <b>D</b> Push-pull 5V, $\pm 30$ mA	<b>B</b> PVC cable, radial

<sup>1</sup> DC 10 - 30 V: only with output "K" available

<sup>2</sup> Output code "K":  $\pm 10$  mA at DC 5 V,  $\pm 30$  mA at DC 10 - 30 V

<sup>3</sup> Output code "K": short-circuit-proof

## Incremental

### ORDERING INFORMATION

Selection of cable length

Versions with cable outlet (connection A, B, E or F) are available with various lengths of cable. To order your desired cable length, please add the respective code to the end of your ordering code. Further cable lengths on request.

Code	Cable length
without code	1.5 m
-D0	3 m
-F0	5 m
-K0	10 m
-P0	15 m
-U0	20 m
-V0	25 m

### ACCESSORIES

see chapter "Accessories", starting page 322

## Incremental



## NUMBER OF PULSES

- Economical miniature encoder
- High protection IP65
- Output Push-pull or NPN-O.C.
- High mechanical efficiency
- Applications: textile machinery



5 / 10 / 20 / 25 / 28 / 32 / 50 / 60 / 72 / 100 / 128 / 144 / 200 / 250 / 256 / 288 / 300 / 360 / 400 / 500  
/ 512 / 600 / 720 / 900 / 1000 / 1024  
Other number of pulses on request

**TECHNICAL DATA**  
**mechanical**

Housing diameter	40 mm
Shaft diameter	6 mm (Solid shaft)
Flange (Mounting of housing)	Pilot flange
Protection class shaft input (EN 60529)	IP64
Protection class housing (EN 60529)	IP65
Shaft load axial / radial	5 N / 10 N
Max. speed	max. 10 000 rpm
Torque	≤ 1 Ncm
Vibration resistance (DIN EN 60068-2-6)	100 m/s <sup>2</sup> (10 ... 2000 Hz)
Shock resistance (DIN EN 60068-2-27)	1000 m/s <sup>2</sup> (6 ms)
Operating temperature	0 °C ... +60 °C
Storage temperature	-25 °C ... +85 °C
Material shaft	Aluminum
Material housing	Plastic
Weight	approx. 75 g
Connection	Cable, axial

**TECHNICAL DATA**  
**electrical**

General design	as per DIN VDE 0160, protection class III, contamination level 2, overvoltage class II
Supply voltage <sup>1</sup>	Push-pull (D): DC 5 V ±10 % Push-pull (K): ± 10% DC 5 V or DC 10 - 30 V Push-pull antivalent (I): DC 10-30 V Open Collector NPN (S): DC 10-24 V
Max. current w/o load	40 mA (DC 5 V), 30 mA (DC 24 V, with push-pull K, I), 40 mA (DC 24 V, NPN-O.C.)
Max. pulse frequency	DC 5 V: 300 kHz DC 10 - 30 V: 200 kHz DC 10 - 24 V: 50 kHz
Standard output versions <sup>2,3,4</sup>	Push-pull (K): A, B, N, $\overline{A}$ alarm Push-pull 5V, ± 30 mA (D): A, B, N, $\overline{A}$ alarm Push-pull complementary (I): A, B, N, $\overline{A}$ , $\overline{B}$ , $\overline{N}$ , $\overline{A}$ alarm NPN-O.C. (S): A, B, N

## Incremental

### TECHNICAL DATA electrical (continued)

Pulse width error	± max. 25° electrical
Number of pulses	5 ... 1024
Alarm output	NPN-O.C., max. 5 mA
Pulse shape	Square wave
Pulse duty factor	1:1

- <sup>1</sup> With push-pull (K): pole protection  
<sup>2</sup> Output code "K": short-circuit-proof  
<sup>3</sup> NPN-O.C. with internal pull-up resistor = 10 K $\Omega$ , max. pulse frequency = 50 KHz, max. output lead = ± 30 mA, tolerance ≤ ± 30° electrical, delay time ≤ 4 $\mu$ s  
<sup>4</sup> Output description and technical data see chapter "Technical basics"

### ELECTRICAL CONNECTIONS Cable

Colour (PVC)	Output circuit	
	push-pull (K, D), Open Collector (S)	push-pull complementary (I)
white	Channel A	Channel A
white/brown		Channel $\bar{A}$
green	Channel B	Channel B
green/brown		Channel $\bar{B}$
yellow	Channel N	Channel N
yellow/brown		Channel $\bar{N}$
yellow/black	Alarm	Alarm
yellow/red		Sense V <sub>CC</sub>
red	DC 5/ 10 - 30/ 10 - 24 V	DC 10 - 30 V
black	GND	GND

### DIMENSIONED DRAWINGS

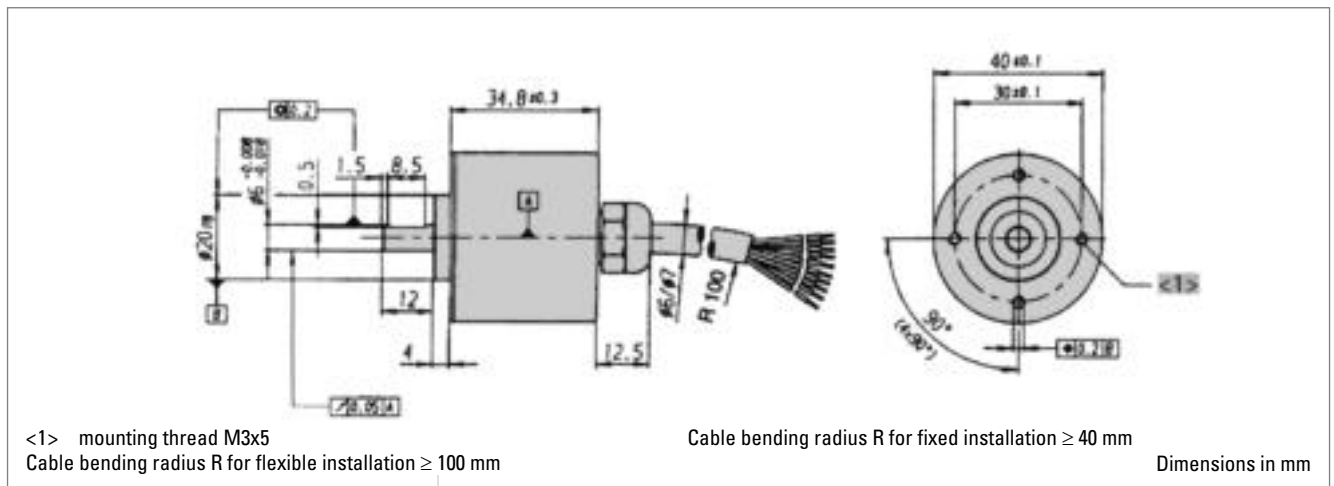

## Incremental

### ORDERING INFORMATION

Type	Number of pulses	Supply voltage 1, 2, 3	Flange, Protection, Shaft	Output 4, 5	Connection
<input type="checkbox"/>	<input type="checkbox"/>	<input type="checkbox"/>	<input type="checkbox"/>	<input type="checkbox"/>	<input type="checkbox"/>
<b>RI42</b>	<b>5 ... 1024</b>	<b>A</b> DC 5 V <b>C</b> DC 10 - 24 V <b>E</b> DC 10 - 30 V	<b>R.41</b> Pilot, IP64, 6 mm	<b>K</b> Push-pull <b>I</b> Push-pull complementary <b>D</b> Push-pull 5V, ± 30 mA <b>S</b> Open Collector NPN	<b>A</b> Cable, axial

<sup>1</sup> DC 5 V: only with output "K", "D" available

<sup>2</sup> DC 10 - 30 V: only with output "K", "I" available

<sup>3</sup> DC 10 - 24 V: only with output "S" available

<sup>4</sup> Output code "K": ±10 mA at DC 5 V, ±30 mA at DC 10 - 30 V

<sup>5</sup> Output code "K" and "I": short-circuit-proof

### ORDERING INFORMATION

#### Selection of cable length

Versions with cable outlet (connection A, B, E or F) are available with various lengths of cable. To order your desired cable length, please add the respective code to the end of your ordering code. Further cable lengths on request.

Code	Cable length
without code	1.5 m
-D0	3 m
-F0	5 m
-K0	10 m
-P0	15 m
-U0	20 m
-V0	25 m

### ACCESSORIES

see chapter "Accessories", starting page 322



## Motor Feedback



Hengstler offers Motor Feedback systems in all performance classes and with the most commonly used interfaces

From modular miniature incremental encoders for **DC and Stepper Motors** in 22 mm diameter up to the absolute AC110 with 50mm hollow shaft Hengstler provides a complete range of Motor Feedback systems.

**For asynchronous motors** and elevators the offering comprises incremental and absolute hollow shaft encoders in singleturn and multiturn versions. Trend-setting is the Incremental OptoASIC with diagnosis system and integrated interpolation electronic which is for the first time used in RI80-E. This enables resolutions of up to 200 000 pulses for good synchronism of electric machines running at low revs.

**For AC Servo Motors** there is an extensive range of feedback products available: Brushless resolvers size 10, 15 and 21 uniquely robust and low priced, incremental comcoders for direct block commutation of BLDC motors in low cost modular version or with integrated bearings and resolutions up to 10 000 pulses per revolution.

Your application requires highest precision and dynamics? Than you are on the right track with the Sine-wave encoder S21 and the absolute Acuro-Drive encoder. Latest OptoASIC technology and a true geared multiturn provides obvious advantages regarding performance and reliability. Hengstler offers the Acuro-Drives series with the open, highspeed, digital interface BiSS. With the open source BiSS interface the proprietary lock-in situation with absolute motorfeedback systems is broken up with the benefit of an increasing range of suppliers.

### **One Size fits all:**

No matter whether your servo application requires resolvers, incremental comcoders or absolute Multiturn encoders - the complete range in size 15 with resolver compatible mounting is available from Hengstler. The benefit of this is, that the B-side of the motor can be resolver style and doesn't need to be customized, depending on the feedback. The Feedback type can be selected according to customer demands or required resolution and technology. This helps reducing variation of parts and stock and enables improved delivery times.

## Miniature, DC & Stepper Motors Incremental



### GENERAL INFORMATION

- Ideal for position and speed sensing in small machines and actuators
- Low power standby mode is ideal for battery powered devices
- Max. output frequency: 200 kHz
- Resolution to 512 lines/rev



The type E9 incremental optical encoder provides high performance feedback for precision motion control in a very small package.

Its small envelope makes it ideal for instrument axes for position and speed control in mechanisms too small to accept standard encoders.

Its high performance, advanced features, and competitive pricing make it the encoder of choice for a broad range of applications.

The E9 optical encoders utilize a patentpending ASIC that integrates all encoder electronics, including the optoelectronic sensors, which enhances reliability and accuracy. Outputs are quadrature A and B channels with up to 512 lines per rev, an index pulse, unique up/down and rotation direction signals (version 2) or complementary CMOS compatible (version 1). The E9 also has a low-power standby mode to conserve power in battery-operated applications.

### TECHNICAL DATA mechanical

Housing diameter	22 mm
Mounting depth	20 mm
Shaft diameter	1.5 mm / 2 mm / 2.5 mm / 3 mm / 4 mm / 1 1/8" / 0.156" (Hub shaft)
Hollow shaft tolerance	+0.010 / -0.000 mm
Axial endplay of mounting shaft (hubshaft)	± 0.076 mm + 0.127 mm / - 0.076 mm + 0.187 mm / - 0.076 mm
Radial runout of mating shaft (hubshaft)	± 0.0125 mm
Max. speed	max. 12 000 rpm
Moment of inertia	approx. 0.2 gcm <sup>2</sup>
Operating temperature	-40 °C ... +100 °C
Storage temperature	-50 °C ... +125 °C
Relative humidity	90 %, non-condensing
Weight	5.07 g
Connection	10 pole header (Accessory: 30 cm ribbon cable with connector, ordering code CA0040012)
Recommended mating connector	Thomas & Betts, ordering code 622-1030 (on request)

### TECHNICAL DATA electrical

Supply voltage	DC 5 V ±10 %
Max. current w/o load	10 mA
Standby current	50 µA
Code	Incremental, optical
Max. pulse frequency	200 kHz

Miniature, DC & Stepper Motors Incremental

TECHNICAL DATA  
electrical (continued)

Index pulse width (N)	90° ± 36° electrical
Phasing	90° ± 18° electrical
Symmetry	180° ± 18° electrical
Number of pulses	100 ... 512
Output signals	min. 2.5 V high (VOH), max. 0.5 V low (VOL)
Output current	3 mA sink/source (25°C), 2 mA (100°C)
Pulse shape	Square wave

OUTPUT WAVEFORMS AND CONNECTIONS (Direction viewing encoder cover)

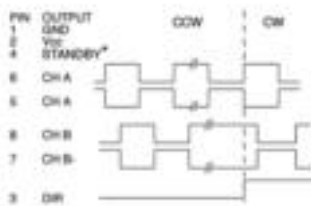

\* For operation, connect STANDBY (4) to Vcc (2)

Figure 1

Code 00 for ordering information

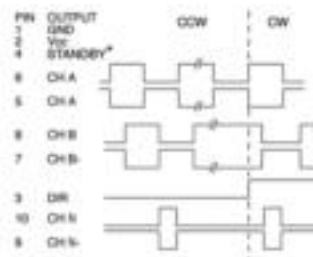

\* For operation, connect STANDBY (4) to Vcc (2)

Figure 2

Code 01 for ordering information

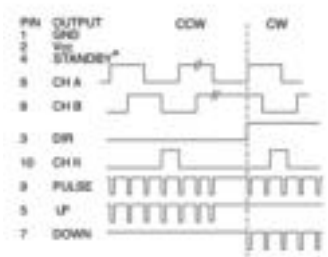

\* For operation, connect STANDBY (4) to Vcc (2)

Figure 3

Code 02 for ordering information

DIMENSIONED DRAWINGS

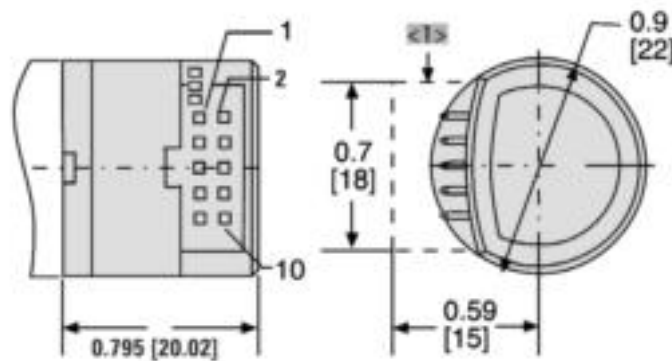

<1> Thomas Betts #622-1030

Dimensions in inch [mm]

## Miniature, DC & Stepper Motors Incremental

### ORDERING INFORMATION

Type	Number of pulses / poles	Shaft Ø	Output	Mounting <sup>1</sup>
<input type="checkbox"/>	<input type="checkbox"/>	<input type="checkbox"/>	<input type="checkbox"/>	<input type="checkbox"/>
<b>E9</b>	0100 / 0 0144 / 0 0200 / 0 0256 / 0 0300 / 0 0360 / 0 0500 / 0 0512 / 0	<b>1,5</b> 1.5 mm <b>2,0</b> 2.0 mm <b>2,5</b> 2.5 mm <b>3,0</b> 3.0 mm <b>125</b> 0.125" <b>156</b> 0.156"	<b>00</b> see Fig. 1 <b>01</b> see Fig. 2 <b>02</b> see Fig. 3	<b>0</b> No mounting base <b>A</b> 4 x M1,6 on 18,5 mm (0,728") B.C. <b>C</b> 2 x #2-56 on 19,05 mm (0,75") B.C. <b>D</b> 3 x #0-80 on 20,9 mm (0,823") B.C. <b>E</b> 2 x #2-56 on 46,02 mm (1,812") B.C.

<sup>1</sup> Further information (drawings and mounting) see homepage [www.hengstler.com](http://www.hengstler.com)

#### Important:

To properly install type E9, a specialized **mounting kit** must be purchased.  
Only **one** kit is required to install any number of encoders with the same hub shaft size.

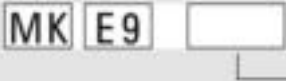

Hub shaft	
<b>1.5</b>	1.5 mm
<b>2.0</b>	2.0 mm
<b>2.5</b>	2.5 mm
<b>3.0</b>	3.0 mm
<b>125</b>	0.125 inch
<b>156</b>	0.156 inch

Please designate hub shaft diameter.

Example: Kit for installing encoders with 3.0 mm hub shaft = MK E9 3.0

### ACCESSORIES

see chapter "Accessories", starting page 322

## Miniature, DC & Stepper Motors Incremental



### GENERAL INFORMATION

- Ideal for position and speed sensing in small machines and actuators
- Max. output frequency: 200 kHz
- Resolution to 512 lines/rev



With a total length less than 15mm and a very low mass, the type M9 incremental optical encoder is ideally suited for use on the moving heads of pick-and-place type machines.

The M9 may be used as direct replacements for most Hewlett Packard HEDS-5XXX encoders with no changes to the motor or cable.

The M9 provides high performance feedback for precision motion control in a very small package. Its small envelope makes it ideal for instrument axes for position and speed control in mechanisms too small to accept standard encoders.

Its high performance, advanced features, and competitive pricing make it the encoder of choice for a broad range of applications.

It utilizes an ASIC that integrates all encoder electronics, including the optoelectronics sensors, which enhances reliability and accuracy.

Outputs are single-ended quadrature A and B channels with up to 512 lines per rev plus an index pulse.

### TECHNICAL DATA mechanical

Housing diameter	22 mm
Mounting depth	14.8 mm
Shaft diameter	1.5 mm / 2 mm / 2.5 mm / 3 mm / 4 mm / 1/8" / 0.156" (Hub shaft)
Hollow shaft tolerance	+0.010 / -0.000 mm
Axial endplay of mounting shaft (hubshaft)	± 0.076 mm + 0.127 mm / - 0.076 mm + 0.178 mm / - 0.076 mm
Radial runout of mating shaft (hubshaft)	± 0.0125 mm
Max. speed	max. 12000 rpm
Moment of inertia	approx. 0.11 gcm <sup>2</sup>
Operating temperature	-40 °C ... +100 °C
Storage temperature	-50 °C ... +125 °C
Relative humidity	90 %, non-condensing
Weight	4.14 g
Connection	5 pole header (Accessory: 30 cm ribbon cable with connector, ordering code CA0050012)
Recommended mating connector	AMP, ordering code 103675-4 (on request)

### TECHNICAL DATA electrical

Supply voltage	DC 5 V ±10 %
Max. current w/o load	10 mA
Code	Incremental, optical

Miniature, DC & Stepper Motors Incremental

TECHNICAL DATA  
electrical (continued)

Max. pulse frequency	200 kHz
Index pulse width (N)	90° ± 36° electrical
Phasing	90° ± 18° electrical
Symmetry	180° ± 18° electrical
Number of pulses	100 ... 512
Output signals	min. 2.5 V high, max. 0.5 V low
Output current	6 mA (25°C), 4 mA (100°C)

DIMENSIONED DRAWINGS

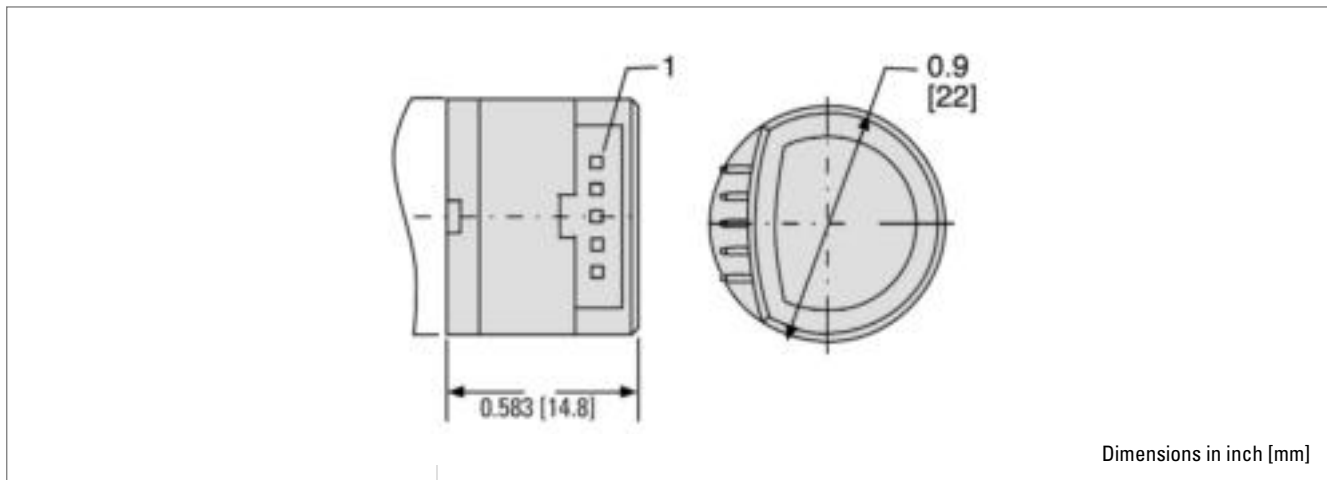

OUTPUT WAVEFORMS AND CONNECTIONS (Direction viewing encoder cover)

PIN	FUNCTION		CABLE WIRE
1	GND		BLACK
2	CH N		BLUE
3	CH A		WHITE
4	+U <sub>B</sub>		RED
5	CH B		BROWN

### ORDERING INFORMATION

Type	Number of pulses / poles	Mounting <sup>1</sup>	Shaft Ø	Connection
<input type="checkbox"/>	<input type="checkbox"/>	<input type="checkbox"/>	<input type="checkbox"/>	<input type="checkbox"/>
<b>M9</b>	0100 / 0 0144 / 0 0200 / 0 0256 / 0 0300 / 0 0360 / 0 0500 / 0 0512 / 0	<b>0</b> No mounting base <b>A</b> 4 x M1,6 on 18,5 mm (0,728") B.C. <b>C</b> 2 x #2-56 on 19,05 mm (0,75") B.C. <b>D</b> 3 x #0-80 on 20,9 mm (0,823") B.C. <b>E</b> 2 x #2-56 on 46,02 mm (1,812") B.C.	<b>1,5</b> 1.5 mm <b>2,0</b> 2.0 mm <b>2,5</b> 2.5 mm <b>3,0</b> 3.0 mm <b>4,0</b> 4.0 mm <b>125</b> 0.125" <b>156</b> 0.156"	<b>2</b> Flying leads <b>1</b> 5 pole header

<sup>1</sup> Further information (drawings and mounting) see homepage [www.hengstler.com](http://www.hengstler.com)

#### Important:

To properly install type M9, a specialized **mounting kit** must be purchased. Only **one** kit is required to install any number of encoders with the same hub shaft size.



Hub shaft	
<b>1.5</b>	1.5 mm
<b>2.0</b>	2.0 mm
<b>2.5</b>	2.5 mm
<b>3.0</b>	3.0 mm
<b>125</b>	0.125 inch
<b>156</b>	0.156 inch

Please designate hub shaft diameter.

Example: Kit for installing encoders with 3.0 mm hub shaft = MK M9 3.0

### ACCESSORIES

see chapter "Accessories", starting page 322

## Miniature, DC & Stepper Motors Incremental



### GENERAL INFORMATION

- Ideal economical feedback device for servo and step motors
- Short axial length and compact 1.5 inch diameter
- Easy "snap-on" installation
- High resolution to 1024 lines/rev and 200 kHz bandwidth
- Max. output frequency: 200 kHz
- Replacement for HP 5540
- CE qualified



The type M14 of incremental optical encoders provides high performance feedback for precision motion control in a small, low cost package.

Its high performance, advanced features, and competitive pricing make it the encoder of choice for a broad range of applications.

The M14 optical encoder utilizes a patentpending ASIC that integrates all encoder electronics, including the optoelectronic sensors, which enhances reliability and accuracy.

Quadrature A and B channels with up to 1024 lines per revolution and reference pulse are output as single-ended TTL/CMOS compatible signals.

The M 14 can be used as drop-in replacement for HP 5540.

### TECHNICAL DATA mechanical

Housing diameter	38 mm
Mounting depth	17.2 mm
Shaft diameter	3 mm / 4 mm / 5 mm / 6 mm / 8 mm / 0.1248" / 0.1873" / 0.2498" / 0.2501" / 0.3123" / 0.3748" / 3/4" (Hub shaft)
Hollow shaft tolerance	+0.010 / -0.000 mm
Axial endplay of mounting shaft (hubshaft)	± 0.076 mm + 0.127 mm / - 0.076 mm + 0.178 mm / - 0.076 mm
Radial runout of mating shaft (hubshaft)	± 0.0125 mm
Max. speed	max. 12 000 rpm
Moment of inertia	approx. 0.13 gcm <sup>2</sup>
Operating temperature	-40 °C ... +100 °C
Storage temperature	-50 °C ... +125 °C
Relative humidity	90 %, non-condensing
Weight	6.2 g
Connection	5 pole header (Accessory: 30 cm ribbon cable with connector, ordering code CA0050012)
Recommended mating connector	AMP, ordering code 103969-4 (on request)

### TECHNICAL DATA electrical

Supply voltage	DC 5 V ±10 %
Max. current w/o load	10 mA
Code	Incremental, optical
Max. pulse frequency	200 kHz
Index pulse width (N)	90° ± 36° electrical
Phasing	90° ± 18° electrical
Symmetry	180° ± 18° electrical



Miniature, DC & Stepper Motors Incremental

TECHNICAL DATA  
electrical (continued)

Number of pulses	200 ... 1024
Output signals	min. 2.5 V high, max. 0.5 V low
Output current	6 mA (25°C), 4 mA (100°C)

DIMENSIONED DRAWINGS

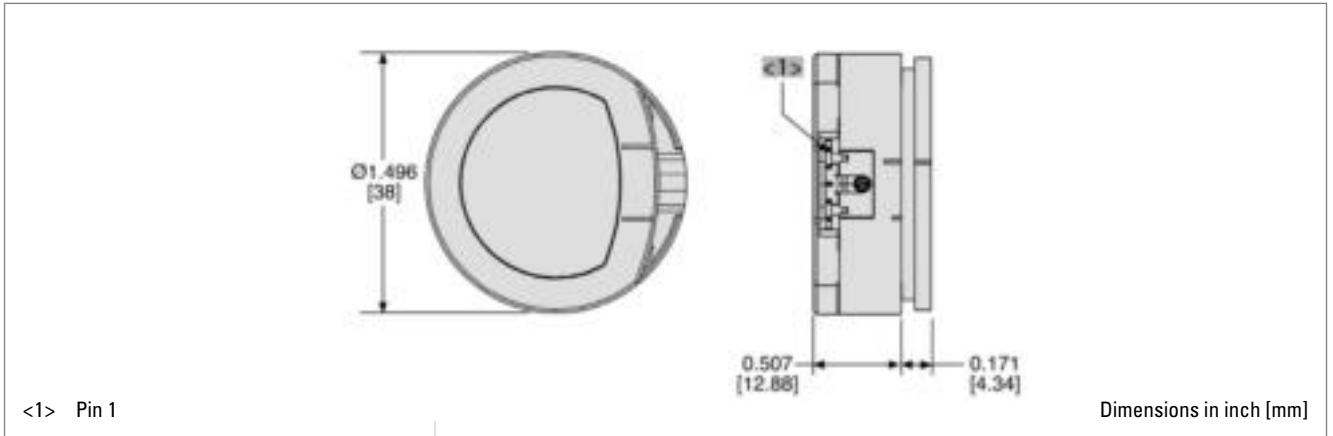

OUTPUT WAVEFORMS AND CONNECTIONS (Direction viewing encoder cover)

PIN	FUNCTION		CABLE WIRE
1	GND		BLACK
2	CH N		BLUE
3	CH A		WHITE
4	+U <sub>B</sub>		RED
5	CH B		BROWN

**Miniature, DC & Stepper Motors Incremental**

**ORDERING INFORMATION**

Type	Number of pulses / poles	Mounting <sup>1</sup>	Shaft Ø
<input type="checkbox"/>	<input type="checkbox"/>	<input type="checkbox"/>	<input type="checkbox"/>
<b>M14</b>	0200 / 0 0400 / 0 0500 / 0 0512 / 0 Higher on request	<b>0</b> No mounting base <b>A</b> 2 x #2-56 on 32,51 mm (1,28") B.C. <b>B</b> 3 x #0-80 on 20,9 mm (0,823") B.C. <b>C</b> 2 x #2-56 on 19,05 mm (0,75") B.C.	<b>3,0</b> 3.0 mm <b>4,0</b> 4.0 mm <b>5,0</b> 5 mm <b>6,0</b> 6 mm <b>8,0</b> 8 mm <b>125</b> 0.125" <b>187</b> 0.1873" <b>249</b> 0.2498" <b>250</b> 0.2501" <b>312</b> 0.2501" <b>374</b> 0.3748" <b>375</b> 0.3748"

<sup>1</sup> Further information (drawings and mounting) see homepage [www.hengstler.com](http://www.hengstler.com)

**Important:**

To properly install type M14, a specialized **mounting kit** must be purchased. Only one kit is required to install any number of encoders with the same hub shaft size.

Hub shaft			
<b>3.0</b>	3 mm	<b>187</b>	0.1873 inch
<b>4.0</b>	4 mm	<b>249</b>	0.2498 inch
<b>5.0</b>	5 mm	<b>250</b>	0.2501 inch
<b>6.0</b>	6 mm	<b>312</b>	0.3123 inch
<b>8.0</b>	8 mm	<b>374</b>	0.3748 inch
<b>125</b>	0.1248 inch	<b>375</b>	0.3750 inch

Please designate hub shaft diameter.

Example: Kit for installing encoders with 0.1248" mm hub shaft = MK M14 125

**ACCESSORIES**

see chapter "Accessories", starting page 322

### OVERVIEW

Our hollow shaft encoder industry types are particularly suitable as a motor feedback product for asynchronous- and DC motors. Due to the partially higher requirements on the operating temperature, there are specially developed high temperature versions (-TD) available, among certain types.



#### HOLLOW SHAFT ENCODER RI36-H

- Miniature industry encoder for high numbers of pulses (5 .. 3600)
- Hollow shaft (up to 10mm)
- Short overall length
- Easy and quick mounting procedure

There are two different spring tethers available.

Detailed description: Page 104



#### HOLLOW SHAFT ENCODERS RI58-D, TD, -G, TG

- Flexible hollow shaft design up to diameter 14 mm (-D,TD), 15mm hollow shaft (-G,TG)
- Short overall length
- Easy installation by means of clamping ring or blind shaft
- Operating temperature up to 100°C (RI58 TD and TG)
- High number of pulses (5 .. 5000) with -D
- Limited number of pulses (4 .. 2500) with TD and (50 .. 2500) with TG

The RI58 hollow shaft family offers a broad spectrum of mounting possibilities and is the right choice for all drive systems because of its high temperature option.

Detailed description of RI58-D, TD: Page 113

Detailed information of RI58-G, TG Page 122



#### HOLLOW SHAFT ENCODER RI76TD

- Through hollow shaft with up to diameter 42 mm
- Short overall length with an outside diameter of only 76 mm
- Easy installation by means of clamping ring
- Operating temperature up to 100 °C

Different Mounting options are available.

Detailed description: Page 132



#### HOLLOW SHAFT ENCODER RI80-E

- Incremental Output
- 30...45 mm hollow shaft
- Rugged mechanical design
- Unbreakable disc
- Integrated diagnostic system
- Wide voltage range DC 5 ... 30 V

The RI80-E is the first encoder using the latest Hengstler OptoAsic technology.

Detailed description: Page 136

**OVERVIEW**

Our absolute hollow shaft encoders of the Acuro family are particularly suitable as a motor feedback product for asynchronous- and DC motors, with special requirements concerning dynamics and absolute positioning. Besides the standard interfaces BiSS and SSI they offer additional Sin Cos of output signals.

**ABSOLUTE HOLLOW SHAFT ENCODER AC58**

- Absolute standard industry encoder with high resolution
- Hollow shaft (up to 12 mm)
- Short overall length
- Easy and quick mounting procedure

The AC58 offers all characteristics of the Acuro family in one universal design.

Detailed description: [Page 147](#)

**ABSOLUTE HOLLOW SHAFT ENCODER AC110**

- Robust absolute industry encoder with high resolution
- Hollow shaft (up to 50mm)
- Short overall length
- Easy and quick mounting procedure

The AC110 offers all characteristics of the Acuro family for applications with large shaft diameters (elevators, direct drives).

Detailed description: [Page 194](#)

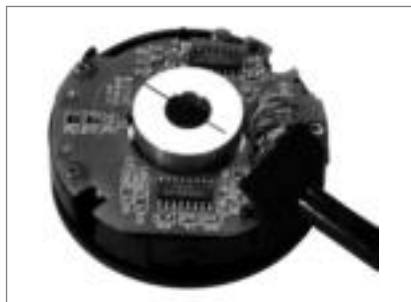
**AC-Synchronous & BLDC Motors Incremental**

**TECHNICAL DATA**  
**mechanical**

- Modular hollow shaft encoder, ideal for BLDC, DC-Servo and Stepper feedback
- Through hollow shaft  $\varnothing$  6 ... 12,7 mm
- Incremental + Commutation
- Incremental signals A, B, N and 4, 6 or 8 pole
- Outside diameter 53 mm
- Mounting depth: only 23 mm
- Maximum speed: 12,000 rpm
- Standard Operating temperature: -40 ... +120°C
- Easy installation and alignment

Housing diameter	53 mm
Mounting depth	22.9 mm
Shaft diameter	6 mm / 6.35 mm / 8 mm / 9.52 mm / 10 mm / 11.11 mm / 12 mm / 12.7 mm (Hub shaft)
Protection class shaft input (EN 60529)	IP50
Protection class housing (EN 60529)	with cover: IP50
Hollow shaft tolerance	+0.026 mm/ -0.000 mm
Mating shaft length	min. 12 mm max. 19 mm
Axial endplay of mounting shaft (hubshaft)	+ 0.3 mm / - 0.21 mm
Radial runout of mating shaft (hubshaft)	Includes shaft perpendicularity to mounting surface: $\pm$ 0.05 mm
Max. speed	max. 12 000 rpm
Acceleration	100 000 rad/s <sup>2</sup>
Moment of inertia	approx. 4.7 gcm <sup>2</sup>
Vibration resistance (DIN EN 60068-2-6)	25 m/s <sup>2</sup> (5 ... 2000 Hz)
Shock resistance (DIN EN 60068-2-27)	500 m/s <sup>2</sup> (11 msec)
Operating temperature	-40 °C ... +120 °C
Storage temperature	-40 °C ... +85 °C
Relative humidity	90% noncondensing
Material shaft	Aluminum
Material housing	Glass fiber-reinforced plastic
Weight	max. 85g
Connection	Shielded cable or dual row connector

**TECHNICAL DATA**  
**electrical**

Supply voltage	DC 5 V or DC 12 V $\pm$ 10 %
Max. current w/o load	100 mA (Incremental: DC 5 or 12 V $\pm$ 10 % (excluding output load)), 75 mA (Commutation: DC 5 or 12 V $\pm$ 10 % (excluding output load))
Code	Incremental with commutation, optical
Accuracy	Incremental signals: $\pm$ arc-mins max. edge to edge Commutation signals: $\pm$ arc-mins max.
Max. pulse frequency	200 kHz

AC-Synchronous & BLDC Motors Incremental

TECHNICAL DATA  
electrical (continued)

Phasing	Incremental signals (A leads B): $90^\circ \pm 18^\circ$ electrical Commutation signals (U leads V leads W): 8 Pole: $30^\circ$ , 6 Pole: $60^\circ$ , 4 Pole: $^\circ$ mechanical
Index pulse width (N)	Incremental signals: $180^\circ \pm 18^\circ$ electrical $180^\circ \pm 36^\circ$ elektrisch
Standard output versions	NPN-O.C.: A, B, N RS422: A, B, N, $\bar{A}$ , $\bar{B}$ , $\bar{N}$ NPN-O.C. (commutation): U, V, W RS422 (commutation): U, V, W, $\bar{U}$ , $\bar{V}$ , $\bar{W}$

DIMENSIONED DRAWINGS

<1> 5/64" (2 mm) hex key  
 <2> cw (clockwise)  
 <3> ccw (counter clockwise)  
 <4> 2 x 0.125"  $\varnothing$  (3.2 mm) on 1.812"  $\varnothing$  B.C.(46 mm)  
 <5> Mounting hole axis  
 <6> #1 Phillips alignment screw  
 <7> Index mark on hub

<8> for blind hub clamp screw: align index mark on hub with vertical edge on housing to properly orient hub clamp screw to hex key access hole thru side of housing  
 <9> 80 offset between mounting hole axis and active index output (centered in adjustment range)  
 ■ Index sensor position

Dimensions in inch (mm)

ORDERING INFORMATION

Type	Number of pulses	Poles commutation <sup>2</sup>	Housing	Electrical <sup>3,4,5</sup>	Shaft $\varnothing$	Connection
<input type="checkbox"/>	<input type="checkbox"/>	<input type="checkbox"/>	<input type="checkbox"/>	<input type="checkbox"/>	<input type="checkbox"/>	<input type="checkbox"/>
<b>M53</b>	<b>0500</b> <b>0512</b> <b>1000</b>	<b>0</b> Without <b>4</b> 4 pole <b>6</b> 6 pole <b>8</b> 8 pole	<b>0</b> Without cover <b>2</b> Axial exit (for shielded cable with pcb connector) <b>1</b> Radial exit cover (for shielded cable)	<b>0</b> U inc = DC 5 V, output inc = NPN-O.C. <b>1</b> U inc = DC 12 V, output inc = NPN-O.C. <b>3</b> U inc = DC 5 V, output inc = RS422 <b>6</b> U inc = DC 5 V, output inc = RS422, U com = DC 5 V, output com = NPN-O.C. <b>9</b> U inc = DC 5 V, output inc = RS422, U com = DC 5 V, output com = RS422	<b>A</b> 6.35 mm (1/4") <b>B</b> 6.35 mm (1/4") <b>C</b> 11.11 mm (7/16") <b>D</b> 12.7 mm (1/2") <b>E</b> 6 mm <b>F</b> 8 mm <b>G</b> 10 mm <b>H</b> 12 mm	<b>A ... H</b> Screened cable radial (A = 30 cm, B = 60 cm ...) <b>1 ... 8</b> Dual row connector with mating ribbon cable (1 = 30 cm, 2 = 60 cm ...)

<sup>1</sup> allowed combinations see available combinations (pulses/poles)  
<sup>2</sup> allowed combinations see available combinations (pulses/poles)  
<sup>3</sup> U inc: Supply voltage incremental, U com: Supply voltage commutation (only if commutation selected)  
<sup>4</sup> Code Electrical "0", "1", "3": only incremental, without commutation  
<sup>5</sup> Code Electrical "6", "9": inkremental plus commutation signals  
<sup>6</sup> Connection code "A" ... "H": only with output = RS 422

AC-Synchronous & BLDC Motors Incremental



- Compact hollowshaft motor encoder, ideal for BLDC, DC-Servo and Stepper feedback
- Through hollow shaft Ø 6 mm
- Incremental signals A, B, N
- Resolution up to 2048 ppr
- 6 or 10 pole commutation signals
- Frequency response to 300 kHz
- Resolver compatible mounting
- Operating temperature up to 120 °C
- Mounting depth: 22.4 mm



NUMBER OF PULSES

1024, 2048;  
optional 6 or 10 pole commutation signals

GENERAL INFORMATION

The type F10 encoder provides high performance, cost effective feedback for stepper and servo motor applications. The F10 offers compact package dimensions and flying leads for a low-profile installation. A size 10 servo ring allows easy mounting and replacement of pancake resolvers with high tolerance to motor shaft movement and 360 degrees of adjustment to align the signal outputs to the shaft position.

TECHNICAL DATA  
mechanical

Housing diameter	31.7 mm
Mounting depth	22.5 mm
Shaft diameter	6 mm (Hub shaft)
Flange (Mounting of housing)	Servo flange
Hollow shaft tolerance	+0.025 mm/ -0.000 mm (+0.001"/ -0.000")
Mounting	26.54 mm (1.045") flexible servo ring (size 10 pancake resolver equivalent)
Axial endplay of mounting shaft (hubshaft)	± 0.25 mm
Radial runout of mating shaft (hubshaft)	Includes shaft perpendicularity to mounting surface: 0.05 mm
Max. speed	max. 5000 rpm (continuous), max. 12000 rpm (short term)
Acceleration	100 000 rad/s <sup>2</sup>
Bearing life	[(3.6 x 10 <sup>9</sup> ) / rpm] hours, e.g. 605 000 hours at 6000 rpm
Moment of inertia	approx. 1.6 gcm <sup>2</sup>
Vibration resistance (DIN EN 60068-2-6)	2.5 g at 5 to 2000 Hz
Shock resistance (DIN EN 60068-2-27)	50 g for 6 ms duration
Operating temperature	0 °C ... +120 °C
Storage temperature	0 °C ... +120 °C
Relative humidity	90 %, non-condensing
Material shaft	Brass
Material housing	Cast aluminum
Material flange	Aluminum
Material disk	0.76 mm thick glass
Weight	approx. 45 g
Connection	Flying leads

## AC-Synchronous & BLDC Motors Incremental

### TECHNICAL DATA electrical

Supply voltage	DC 5 V $\pm 10\%$
Max. current w/o load	100 mA (Incremental and Commutation, w/o load)
Code	Incremental with commutation, optical
Accuracy	Incremental signals: $\pm 2.5$ arc-mins. max. (edge to edge) Commutation signals: $\pm 6$ arc-mins. max.
Max. pulse frequency	300 kHz
Phasing	Incremental signals (A leads B): A leads B by $90^\circ$ for ccw shaft rotation viewing the shaft clamp end of the encoder Commutation signals (U leads V leads W): U leads V leads W by $120^\circ$
Index to u channel	$\pm 1^\circ$ mech. index pulse center to U channel edge
Index pulse width (N)	$90^\circ$ gated A and B low
Standard output versions	NPN-O.C. (S): A, B, N RS422: A, B, N, $\bar{A}$ , $\bar{B}$ , $\bar{N}$ NPN-O.C. (commutation): U, V, W RS422 (commutation): U, V, W, $\bar{U}$ , $\bar{V}$ , $\bar{W}$
Number of pulses	1024, 2048
Output current	Incremental: $\pm 40$ mA (RS422) Commutation: 8 mA (NPN-O.C) or $\pm 40$ mA (RS 422)

### ELECTRICAL CONNECTIONS

Function <sup>1</sup>	Colour
VCC	red
GND	black
$\bar{A}$	blue/black
A	blue
$\bar{B}$	green/black
B	green
$\bar{N}$	violet/black
N	violet
$\bar{U}$	brown/black
U	brown
$\bar{V}$	grey/black
V	grey
$\bar{W}$	white/black
W	white

<sup>1</sup> availability of function depends on version



AC-Synchronous & BLDC Motors Incremental

DIMENSIONED DRAWINGS

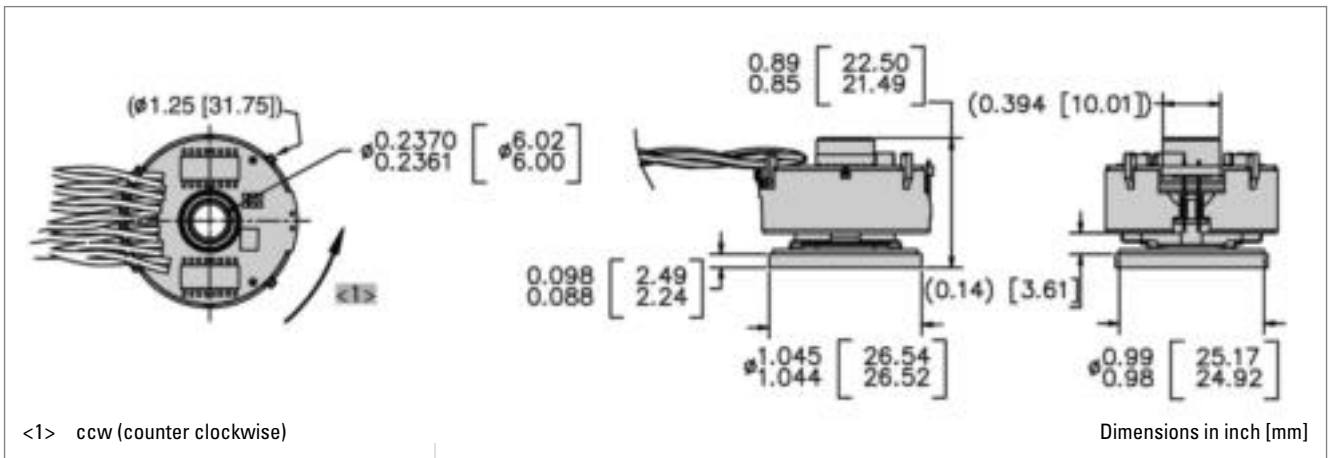

OUTPUT WAVEFORMS

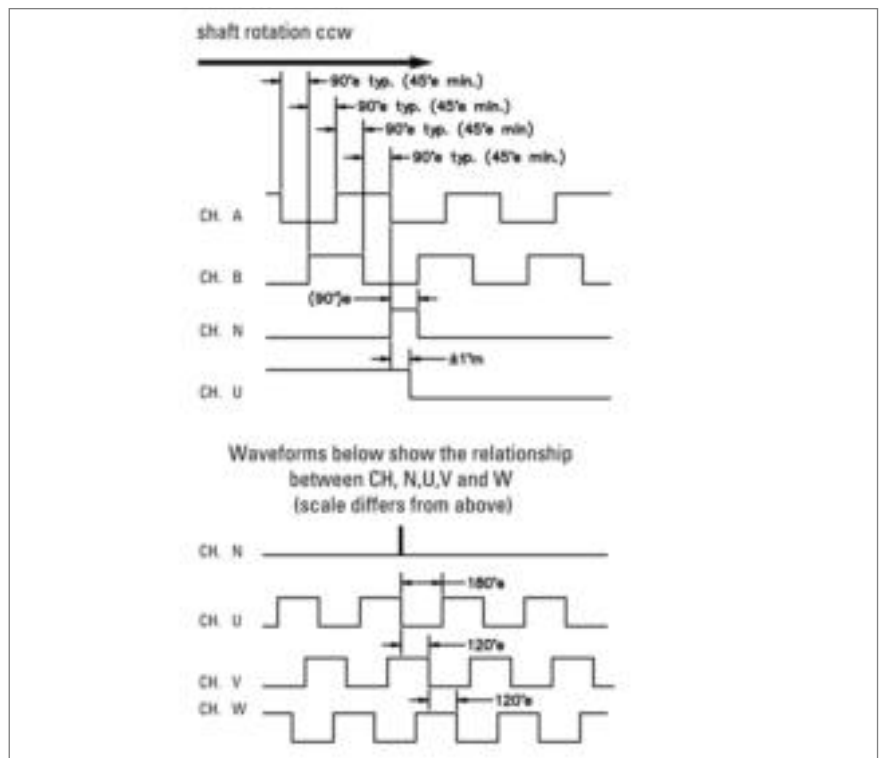

AC-Synchronous & BLDC Motors Incremental

ORDERING INFORMATION

Type	Number of pulses <sup>1</sup>	Poles commutation <sup>2</sup>	Electrical <sup>3,4,5</sup>	Shaft / bore	Connection	Mounting
<input type="checkbox"/>	<input type="checkbox"/>	<input type="checkbox"/>	<input type="checkbox"/>	<input type="checkbox"/>	<input type="checkbox"/>	<input type="checkbox"/>
<b>F10</b>	<b>1024</b> <b>2048</b>	<b>0</b> Without <b>6</b> 6 pole <b>C</b> 10 pole	<b>3</b> U inc = DC 5 V, output inc = RS422 <b>6</b> U inc = DC 5 V, output inc = RS422, U com = DC 5 V, output com = NPN-O.C. <b>9</b> U inc = DC 5 V, output inc = RS422, U com = DC 5 V, output com = RS422	<b>4</b> 6 mm/ through bore	<b>0</b> 16.5 cm flying leads	<b>0</b> Servo ring size 10

<sup>1</sup> allowed combinations see available combinations (pulses/poles)

<sup>2</sup> allowed combinations see available combinations (pulses/poles)

<sup>3</sup> U inc: Supply voltage incremental, U com: Supply voltage commutation (only if commutation selected)

<sup>4</sup> Code Electrical "3": only incremental, without commutation

<sup>5</sup> Code Electrical "6", "9": incremental plus commutation signals

Available combinations (pulses/poles)

Pulses ppr	Number of poles		
	0	6	10 (=C)
1024	X	X	X
2048	X	X	X

# AC-Synchronous & BLDC Motors Incremental



- Compact hollowshaft motor encoder, ideal for BLDC, DC-Servo and Stepper feedback
- Through hollow shaft Ø 9.52 mm
- Incremental signals A, B, N
- Resolution up to 2048 ppr
- 6, 8 or 10 pole commutation signals
- Frequency response to 300 kHz
- Resolver compatible mounting
- Operating temperature up to 120 °C
- Mounting depth: 22.4 mm



**NUMBER OF PULSES**

1024, 2048;  
optional 6, 8 or 10 pole commutation signals

**GENERAL INFORMATION**

The type F15 encoder provides high performance, cost effective feedback for stepper and servo motor applications. The F15 offers compact package dimensions and flying leads for a low-profile installation. A size 15 servo ring allows easy mounting and replacement of pancake resolvers with high tolerance to motor shaft movement and 360 degrees of adjustment to align the signal outputs to the shaft position.

**TECHNICAL DATA**  
mechanical

Housing diameter	36.8 mm
Mounting depth	22.1 mm
Shaft diameter	9.52 mm (Through hollow shaft)
Flange (Mounting of housing)	Servo flange
Hollow shaft tolerance	+0.025 mm/ -0.000 mm (+0.001"/ -0.000")
Mounting	36.83 mm (1.450") flexible servo ring (size 15 pancake resolver equivalent)
Axial endplay of mounting shaft (hubshaft)	± 0.25 mm
Radial runout of mating shaft (hubshaft)	Includes shaft perpendicularity to mounting surface: ± 0.05 mm
Max. speed	max. 5000 rpm (continuous), max. 12000 rpm (short term)
Acceleration	100 000 rad/s <sup>2</sup>
Bearing life	[(3.6 x 10 <sup>9</sup> ) / rpm] hours, e.g. 605 000 hours at 6000 rpm
Moment of inertia	approx. 2.5 gcm <sup>2</sup>
Vibration resistance (DIN EN 60068-2-6)	2.5 g at 5 to 2000 Hz
Shock resistance (DIN EN 60068-2-27)	50 g for 6 ms duration
Operating temperature	0 °C ... +120 °C
Storage temperature	0 °C ... +120 °C
Relative humidity	90 %, non-condensing
Weight	approx. 45 g
Connection	Flying leads

**TECHNICAL DATA**  
electrical

Supply voltage	DC 5 V ±10 %
Max. current w/o load	100 mA (Incremental and Commutation, w/o load)
Code	Incremental with commutation, optical

AC-Synchronous & BLDC Motors Incremental

TECHNICAL DATA  
electrical (continued)

Accuracy	Incremental signals: max. ±2,5 arc-mins. Incremental signals: max. ±6 arc-mins.
Max. pulse frequency	300 kHz
Phasing	Incremental signals (A leads B): A leads B by 90° for ccw shaft rotation viewing the shaft clamp end of the encoder Commutation signals (U leads V leads W): U leads V leads W by 120° for ccw shaft rotation viewing the shaft clamp end of the encoder
Index to u channel	±1° mech. index pulse center to U channel edge
Index pulse width (N)	90° gated A and B low
Standard output versions	RS422: A, B, N, $\bar{A}$ , $\bar{B}$ , $\bar{N}$ NPN-O.C.: U, V, W RS422 (commutation): U, V, W, $\bar{U}$ , $\bar{V}$ , $\bar{W}$
Number of pulses	1024, 2048
Output current	Incremental: max. ±40 mA (RS 422) Commutation: max. ±8 mA (NPN-O.C) or ±40 mA (RS 422)

ELECTRICAL CONNECTIONS

Function <sup>1</sup>	Colour
VCC	red
GND	black
$\bar{A}$	blue/black
A	blue
$\bar{B}$	green/black
B	green
$\bar{N}$	violet/black
N	violet
$\bar{U}$	brown/black
U	brown
$\bar{V}$	grey/black
V	grey
$\bar{W}$	white/black
W	white

<sup>1</sup> availability of function depends on version

DIMENSIONED DRAWINGS

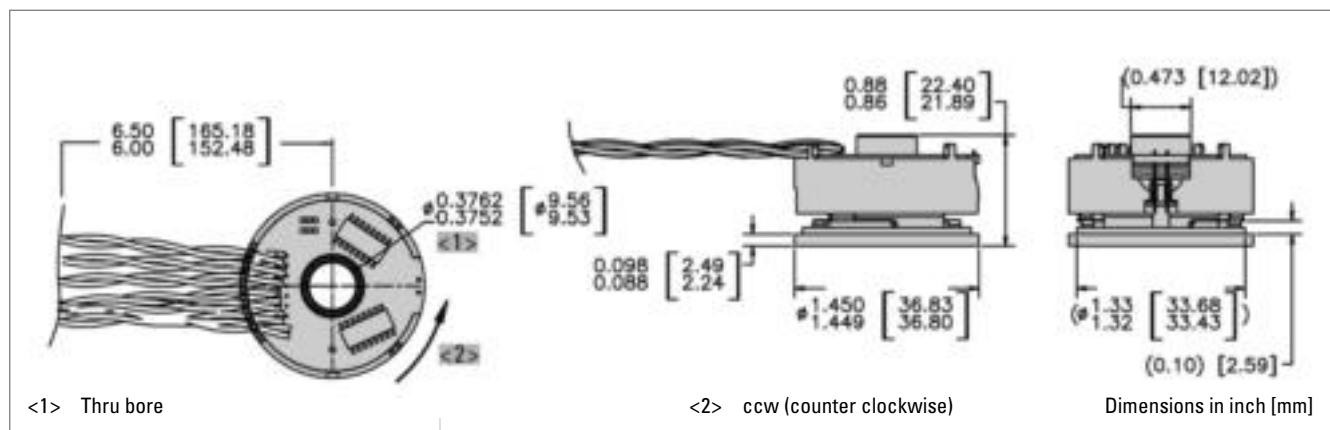

AC-Synchronous & BLDC Motors Incremental

OUTPUT WAVEFORMS

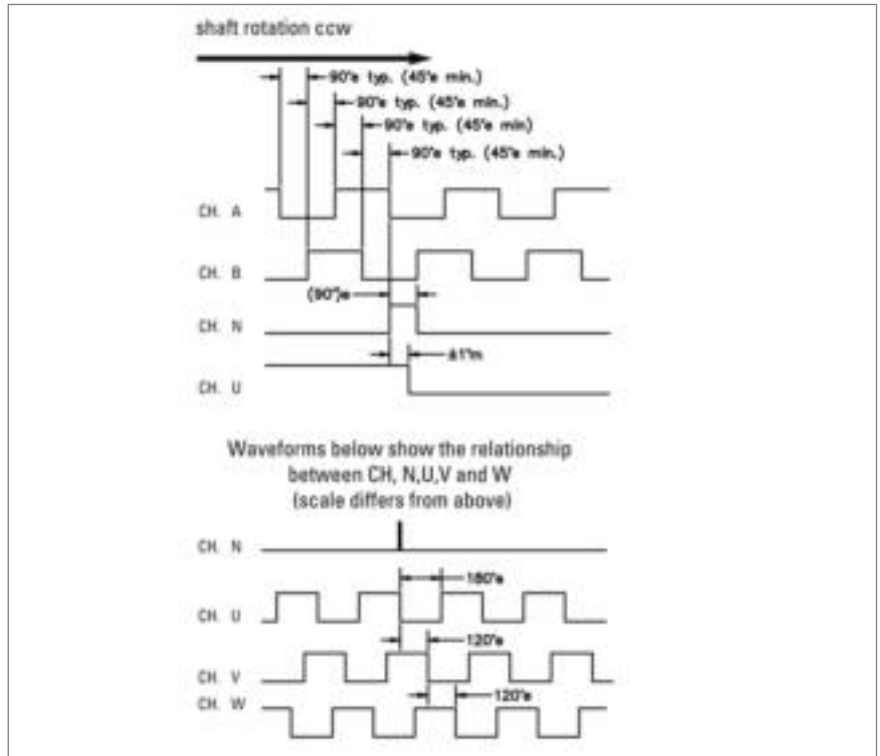

ORDERING INFORMATION

Type	Number of pulses <sup>1</sup>	Poles commutation <sup>2</sup>	Mounting	Electrical <sup>3,4,5</sup>	Shaft / bore	Connection
<input type="checkbox"/>	<input type="checkbox"/>	<input type="checkbox"/>	<input type="checkbox"/>	<input type="checkbox"/>	<input type="checkbox"/>	<input type="checkbox"/>
<b>F15</b>	<b>1024</b> <b>2048</b>	<b>0</b> Without <b>6</b> 6 pole <b>8</b> 8 pole <b>C</b> 10 pole	<b>0</b> Servo ring size 15	<b>3</b> U inc = DC 5 V, output inc = RS422 <b>6</b> U inc = DC 5 V, output inc = RS422, U com = DC 5 V, output com = NPN-0.C. <b>9</b> U inc = DC 5 V, output inc = RS422, U com = DC 5 V, output com = RS422	<b>1</b> 9.52 mm/ through bore	<b>0</b> 16.5 cm flying leads

<sup>1</sup> allowed combinations see available combinations (pulses/poles)

<sup>2</sup> allowed combinations see available combinations (pulses/poles)

<sup>3</sup> U inc: Supply voltage incremental, U com: Supply voltage commutation (only if commutation selected)

<sup>4</sup> Code Electrical "3": only incremental, without commutation

<sup>5</sup> Code Electrical "6", "9": incremental plus commutation signals

Available combinations (pulses/poles)

Pulses ppr	Number of poles			
	0	6	8	10 (=C)
1024	X	X	X	X
2048	X	X	X	X

AC-Synchronous & BLDC Motors Incremental



- Compact hollowshaft motor encoder, ideal for BLDC, DC-Servo and Stepper feedback
- Through hollow shaft Ø 12.7 mm
- Incremental signals A, B, N
- Resolution up to 2048 ppr
- 6, 8, 10, 12 or 16 pole commutation signals
- Frequency response to 300 kHz
- Resolver compatible mounting
- Operating temperature up to 120 °C
- Mounting depth max.: 26 mm



NUMBER OF PULSES

1024, 2048;  
optional 6, 8, 10, 12 or 16 pole commutation signals

GENERAL INFORMATION

The type F21 encoder provides high performance, cost effective feedback for stepper and servo motor applications. The F21 offers compact package dimensions and flying leads for a low-profile installation. A size 21 servo ring allows easy mounting and replacement of pancake resolvers with high tolerance to motor shaft movement and 360 degrees of adjustment to align the signal outputs to the shaft position.

TECHNICAL DATA  
mechanical

Housing diameter	53 mm
Mounting depth	26 mm
Shaft diameter	12.7 mm (Hub shaft)
Flange (Mounting of housing)	Servo flange
Hollow shaft tolerance	+0.025 mm/ -0.000 mm (+0.001"/ -0.000")
Mounting	52.37 mm (2.062") flexible servo ring (size 21 pancake resolver equivalent)
Axial endplay of mounting shaft (hubshaft)	± 0.25 mm
Radial runout of mating shaft (hubshaft)	Includes shaft perpendicularity to mounting surface: + 0.05 mm
Max. speed	max. 5000 rpm (continuous), max. 12 000 rpm (short term)
Acceleration	100 000 rad/s <sup>2</sup>
Bearing life	[(3.6 x 10 <sup>9</sup> ) / rpm] hours, e.g. 605 000 hours at 6000 rpm
Moment of inertia	approx. 2.5 gcm <sup>2</sup>
Vibration resistance (DIN EN 60068-2-6)	2.5 g at 5 to 2000 Hz
Shock resistance (DIN EN 60068-2-27)	50 g for 6 ms duration
Operating temperature	0 °C ... +120 °C
Storage temperature	0 °C ... +120 °C
Relative humidity	90 %, non-condensing
Material shaft	Brass
Material housing	Cast aluminum
Material flange	Aluminum
Material disk	0.76 mm thick glass
Weight	approx. 90 g
Connection	Flying leads

AC-Synchronous & BLDC Motors Incremental

TECHNICAL DATA  
electrical

Supply voltage	DC 5 V $\pm$ 10 %
Max. current w/o load	100 mA (Incremental and Commutation, w/o load)
Code	Incremental with commutation, optical
Accuracy	Incremental signals: max. $\pm$ 2,5 arc-mins. Commutation signals: max. $\pm$ 6 arc-mins.
Max. pulse frequency	300 kHz
Phasing	Incremental signals (A leads B): A leads B by 90° for ccw shaft rotation viewing the shaft clamp end of the encoder Commutation signals (U leads V leads W): U leads V leads W by 120° for ccw shaft rotation viewing the shaft clamp end of the encoder
Index to u channel	$\pm$ 1° mech. index pulse center to U channel edge
Index pulse width (N)	90° gated A and B low
Standard output versions	RS422: A, B, N, $\bar{A}$ , $\bar{B}$ , $\bar{N}$ RS422 (commutation): U, V, W, $\bar{U}$ , $\bar{V}$ , $\bar{W}$ NPN-O.C. (commutation): U, V, W
Number of pulses	1024, 2048
Output current	Incremental: $\pm$ 40 mA (RS 422) Commutation: 8 mA (NPN-O.C) or $\pm$ 40 mA (RS 422)

ELECTRICAL CONNECTIONS

Function <sup>1</sup>	Colour
VCC	red
GND	black
$\bar{A}$	blue/black
A	blue
$\bar{B}$	green/black
B	green
$\bar{N}$	violet/black
N	violet
$\bar{U}$	brown/black
U	brown
$\bar{V}$	grey/black
V	grey
$\bar{W}$	white/black
W	white

<sup>1</sup> availability of function depends on version

AC-Synchronous & BLDC Motors Incremental

DIMENSIONED DRAWINGS

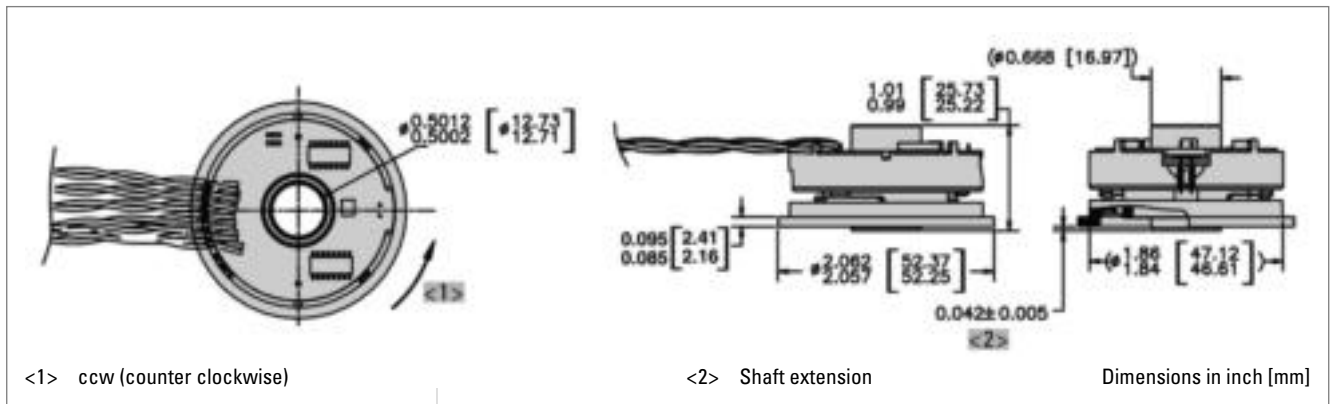

OUTPUT WAVEFORMS

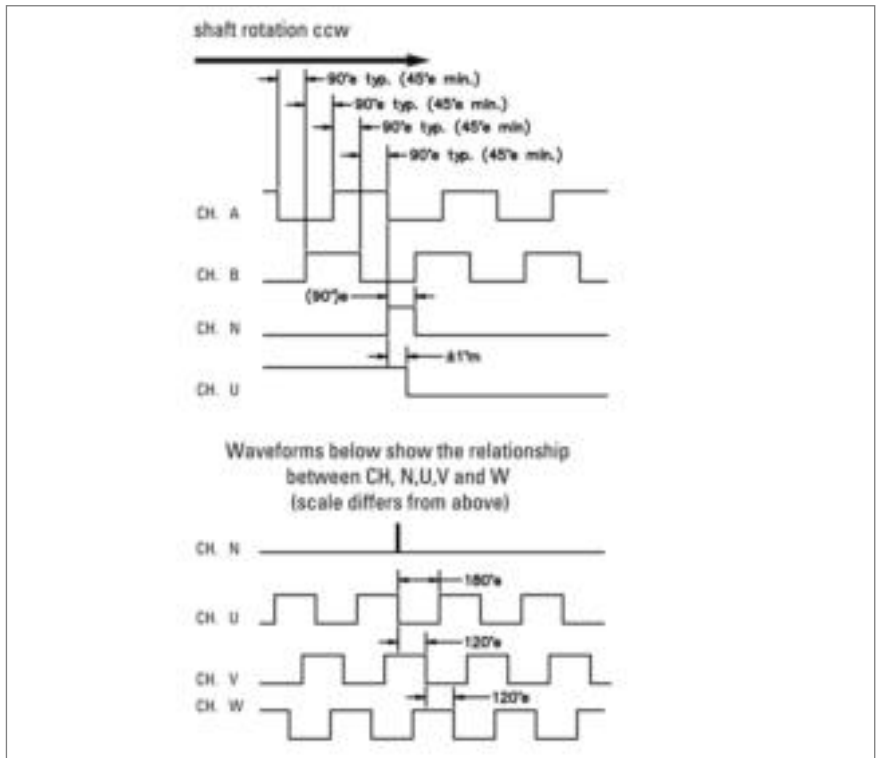



**AC-Synchronous & BLDC Motors Incremental**

**ORDERING INFORMATION**

Type	Number of pulses <sup>1</sup>	Poles commutation <sup>2</sup>	Mounting	Electrical <sup>3,4,5</sup>	Shaft / bore	Connection
<input type="checkbox"/>	<input type="checkbox"/>	<input type="checkbox"/>	<input type="checkbox"/>	<input type="checkbox"/>	<input type="checkbox"/>	<input type="checkbox"/>
<b>F21</b>	<b>1024</b> <b>2048</b>	<b>0</b> Without <b>6</b> 6 pole <b>8</b> 8 pole <b>C</b> 10 pole <b>E</b> 12 pole <b>I</b> 16 pole	<b>0</b> Servo ring size 21	<b>3</b> U inc = DC 5 V, output inc = RS422 <b>6</b> U inc = DC 5 V, output inc = RS422, U com = DC 5 V, output com = NPN-O.C. <b>9</b> U inc = DC 5 V, output inc = RS422, U com = DC 5 V, output com = RS422	<b>3</b> 12.7 mm/ through bore	<b>0</b> 16.5 cm flying leads

<sup>1</sup> allowed combinations see available combinations (pulses/poles)

<sup>2</sup> allowed combinations see available combinations (pulses/poles)

<sup>3</sup> U inc: Supply voltage incremental, U com: Supply voltage commutation (only if commutation selected)

<sup>4</sup> Code Electrical "3": only incremental, without commutation

<sup>5</sup> Code Electrical "6", "9": inkremental plus commutation signals

**Available combinations (pulses/poles)**

Pulses ppr	Number of poles					
	0	6	8	10 (=C)	12 (=E)	16 (=I)
1024	X	X	X	X	X	X
2048	X	X	X	X	X	X

## AC-Synchronous & BLDC Motors Incremental



- Compact hollowshaft motor encoder, ideal for BLDC, DC servo and Stepper feedback
- Incremental + commutation
- Phased Array Technology
- Frequency response to 500 kHz
- Operating temperature up to 120 °C
- Outside diameter 50 mm
- Cable plug-in radial/axial

500, 512, 1000, 1024, 2000, 2048, 2500;  
optional 4, 6 or 8 pole commutation signals

### GENERAL INFORMATION

The type HC20 encoder provides high performance, cost effective feedback for stepper and servo motor controls. A compliant tether allows easy mounting with high tolerance to motor shaft movement and 20 degrees of adjustment to align the signal outputs to the shaft position.

A superior optical configuration allows for generous internal component clearance eliminating potential damage at high ambient operating temperatures. High temperature rated grease is standard for extended bearing life. No special tools are required for installation.

### TECHNICAL DATA mechanical

Housing diameter	50 mm
Mounting depth	36"
Shaft diameter	6 mm / 8 mm
Flange (Mounting of housing)	Tether
Mounting of shaft	Front clamping ring
Protection class shaft input (EN 60529)	IP50
Protection class housing (EN 60529)	IP50
Axial endplay of mounting shaft (hubshaft)	± 0.8 mm
Radial runout of mating shaft (hubshaft)	± 0.2 mm
Max. speed	max. 12 000 rpm
Operating temperature	0 °C ... +120 °C
Storage temperature	-40 °C ... +120 °C
Material housing	Aluminum
Material flange	Aluminum
Connection	Cable, axial or radial

### TECHNICAL DATA electrical

Supply voltage	DC 5 V ±10 %
Max. current w/o load	150 mA (incremental), 175 mA (incremental + commutation)
Code	Incremental with commutation, optical
Accuracy	max. 40 arc-sec.
Max. pulse frequency	500 kHz

AC-Synchronous & BLDC Motors Incremental

TECHNICAL DATA  
electrical (continued)

Phasing	Incremental signals (A leads B): A leads B by 90° for ccw shaft rotation viewing the shaft clamp end of Commutation signals (U leads V leads W): U leads V leads W by 120° for ccw shaft rotation viewing the shaft clamp end of the encoder
Index pulse width (N)	90° gated A and B high
Tolerance N to U	± 1° mech. index pulse center N to U channel edge
Standard output versions	NPN-O.C.: A, B, N RS422: A, B, N, $\bar{A}$ , $\bar{B}$ , $\bar{N}$ NPN-O.C.: U, V, W RS422: U, V, W, $\bar{U}$ , $\bar{V}$ , $\bar{W}$

DIMENSIONED DRAWINGS

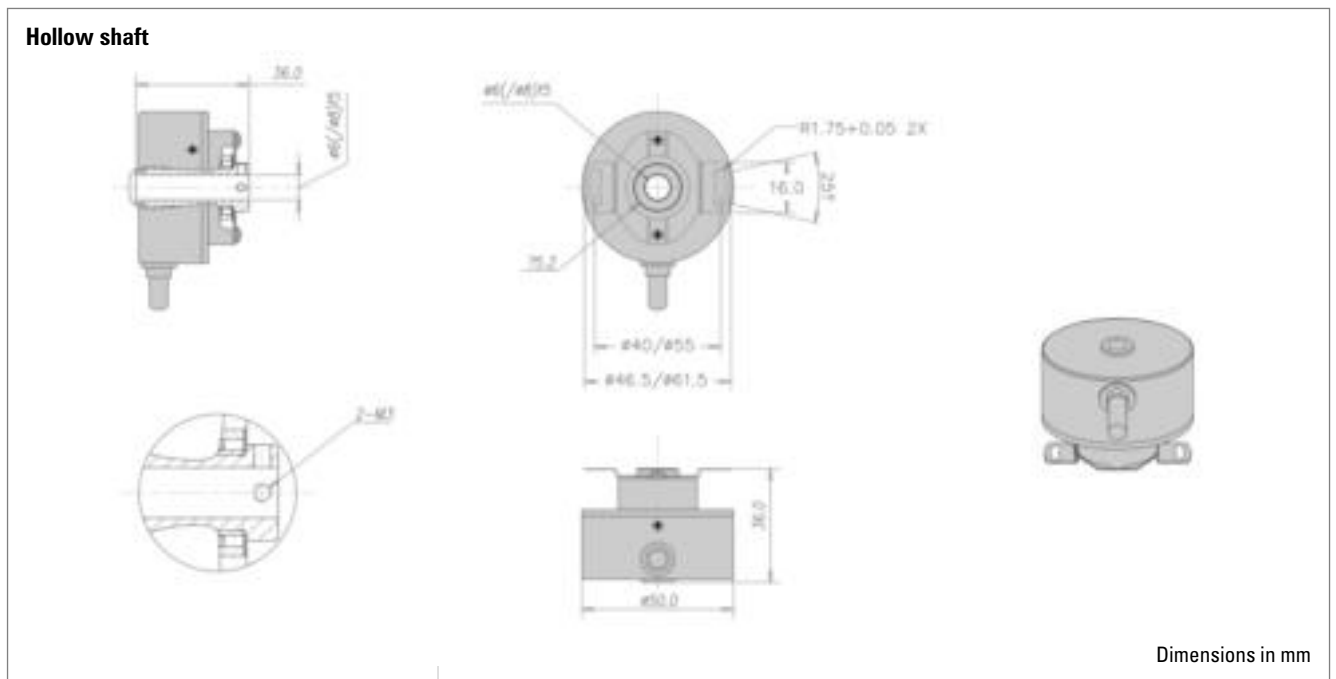

DIMENSIONED DRAWINGS (continued)

Hubshaft

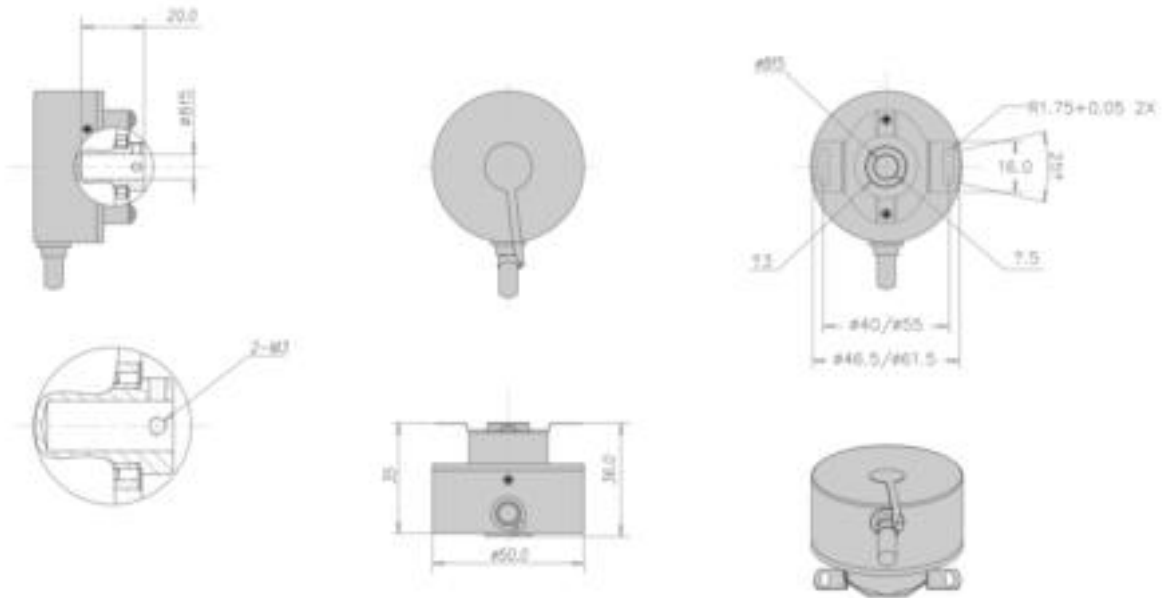

Dimensions in mm

Taper shaft

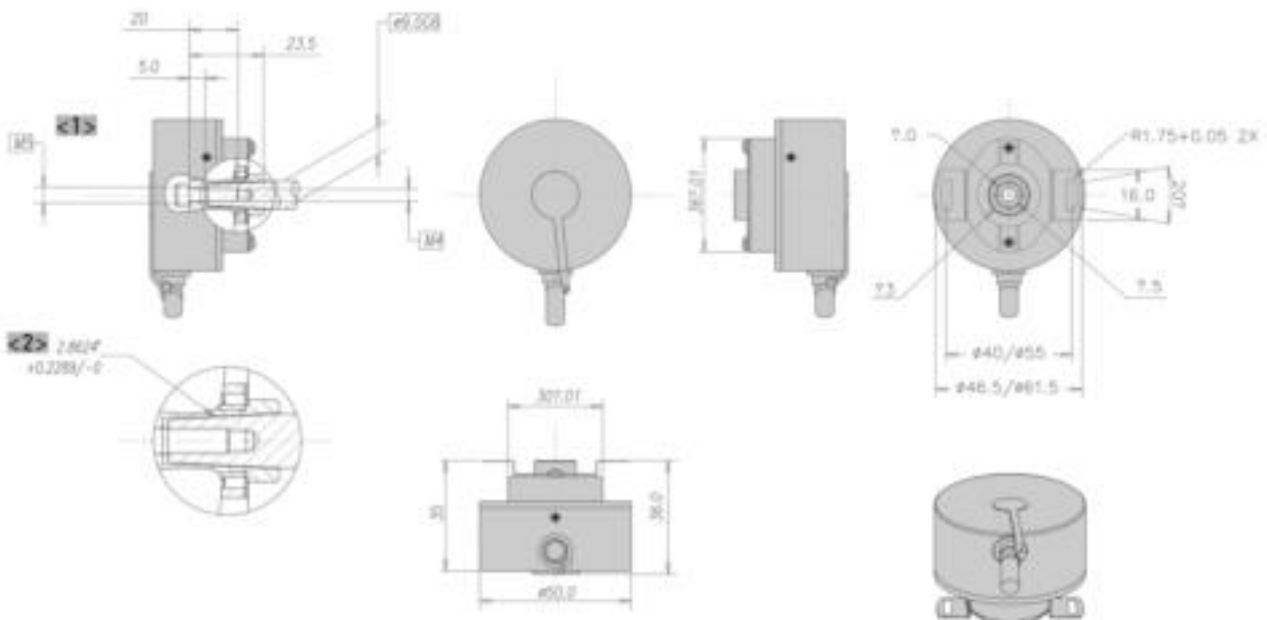

<1> used for dismounting

<2> Taper

Dimensions in mm

AC-Synchronous & BLDC Motors Incremental

ORDERING INFORMATION

Type	Number of pulses <sup>1</sup>	Poles commutation	Mounting	Electrical <sup>3, 4, 5, 6</sup>	Shaft	Connection
<input type="checkbox"/>	<input type="checkbox"/>	<input type="checkbox"/>	<input type="checkbox"/>	<input type="checkbox"/>	<input type="checkbox"/>	<input type="checkbox"/>
<b>HC20</b>	<b>0500</b> <b>1000</b> <b>1024</b> <b>2000</b> <b>2048</b> <b>2500</b>	<b>0</b> Without <b>4</b> 4 pole <b>6</b> 6 pole <b>8</b> 8 pole	<b>0</b> No mounting base	<b>0</b> U inc = DC 5 V, output inc = NPN-0.C. <b>3</b> U inc = DC 5 V, output inc = RS422 <b>6</b> U inc = DC 5 V, output inc = RS422, U com = DC 5 V, output com = NPN-0.C. <b>9</b> U inc = DC 5 V, output inc = RS422, U com = DC 5 V, output com = RS422	<b>1</b> Hub shaft, 6 mm <b>2</b> Hub shaft, 8 mm <b>0</b> Tapered shaft (9 mm; 1:10) <b>3</b> Through hollow shaft, 6 mm <b>4</b> Through hollow shaft, 8 mm	<b>A</b> Cable, 25 mm, radial <b>2</b> Cable, 50 mm, axial <b>B</b> Cable, 50 mm, radial <b>3</b> Cable, 76 mm, axial <b>C</b> Cable, 76 mm, radial <b>4</b> Cable, 0.1 m, axial <b>D</b> Cable, 0.1 m, radial

<sup>1</sup> allowed combinations see available combinations (pulses/poles)

<sup>2</sup> allowed combinations see available combinations (pulses/poles)

<sup>3</sup> U inc: Supply voltage incremental, U com: Supply voltage commutation (only if commutation selected)

<sup>4</sup> Code Electrical "0": only incremental, < 2 048/0 (ppr/poles)

<sup>5</sup> Code Electrical "3": only incremental, without commutation

<sup>6</sup> Code Electrical "6", "9": inkremental plus commutation signals

AC-Synchronous & BLDC Motors Incremental



RF 53 with rear tether

- Solid shaft motor encoder for BLDC and gearless elevator traction machines
- Incremental + commutation
- Up to 10 000 ppr
- Operating temperature up to 120 °C
- IP54
- Outside diameter 53 mm



NUMBER OF PULSES

500 to 10000 ppr;  
optional 4, 6, 8, 10, 12, 16, 20, 24 or 32 pole commutation signals

TECHNICAL DATA  
mechanical

Housing diameter	53 mm
Shaft diameter	Cone solid shaft
Flange (Mounting of housing)	Tether
Mounting of shaft	Center bolt
Protection class shaft input (EN 60529)	IP54
Protection class housing (EN 60529)	IP54
Shaft load axial / radial	20 N / 90 N
Axial endplay of mounting shaft (hubshaft)	± 1.4 mm
Radial runout of mating shaft (hubshaft)	± 0.18 mm
Max. speed	max. 12.000 rpm (continuous), max. 5000 rpm (short term)
Vibration resistance (DIN EN 60068-2-6)	25 m/s <sup>2</sup>
Shock resistance (DIN EN 60068-2-27)	1000 m/s <sup>2</sup>
Operating temperature	-20 °C ... +120 °C
Storage temperature	-40 °C ... +120 °C
Relative humidity	95 %, non-condensing
Material shaft	Stainless Steel
Material housing	Aluminum
Weight	approx. 200 g

AC-Synchronous & BLDC Motors Incremental

TECHNICAL DATA  
mechanical (continued)

Connection	Cable Cable with Sub-D connector PCB connector
------------	--

TECHNICAL DATA  
electrical

Supply voltage	DC 5 V ±10 %
Max. current w/o load	100 mA
Code	Incremental with commutation, optical
Accuracy	Incremental signals: ±2.5 arc-mins. max. (edge to edge) Commutation signals: ±6 arc-mins. max.
Max. pulse frequency	100 kHz
Phasing	Incremental signals (A leads B): 90° Commutation signals (U leads V leads W): U zu V zu W um 120°
Standard output versions	RS422: A, B, N, $\bar{A}$ , $\bar{B}$ , $\bar{N}$ NPN-O.C.: A, B, N
Number of pulses	500 ... 10 000

ELECTRICAL CONNECTIONS  
PIN NUMBERING

PCB connector

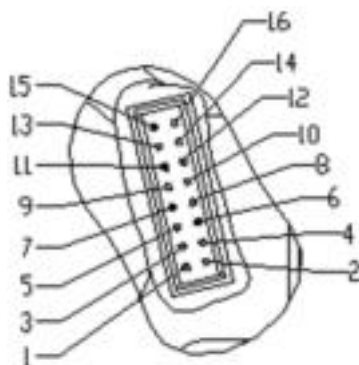

Sub-D connector

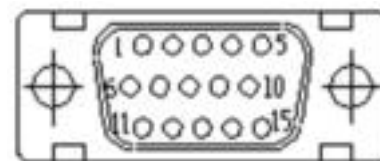

ELECTRICAL CONNECTIONS  
Cable / Sub-D connector, 15 pole

PIN	Signal	Color	SUB-D 15 PIN
1	DC 5 V	red	13
2	U	brown	7
3	0 V	black	14
4	V	grey	9
5	A	blue	1
6	W	white	11
7	$\bar{A}$	blue/black	2
8	N.C.		
9	B	green	3
10	$\bar{U}$	brown/black	8
11	$\bar{B}$	green/black	6
12	$\bar{V}$	grey/black	10
13	N	violet	N.C.
14	$\bar{W}$	white/black	12
15	$\bar{N}$	violet/black	N.C.
16	N.C.		

DIMENSIONED DRAWINGS

Front tether

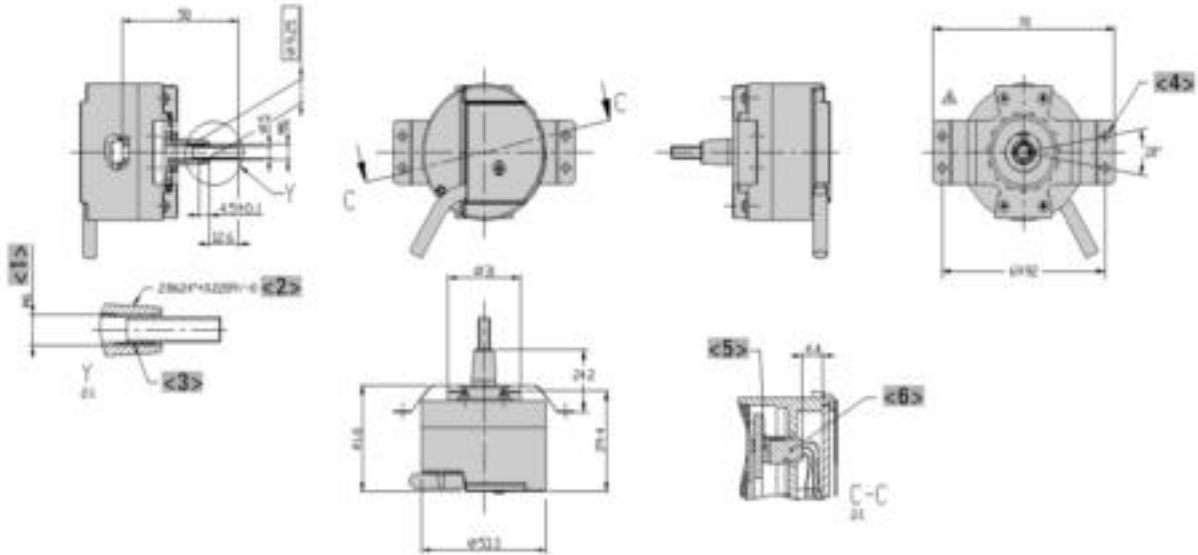

<1> M6 (used for dismounting)

<2> Taper

<3> Internal thread M6x1 x 12 mm deep

<4> Ø 3.2 x on a 71 mm bolt circle (B.C.)

<5> Cable connector 1

<6> Cable connector 2

Dimensions in mm

Rear tether

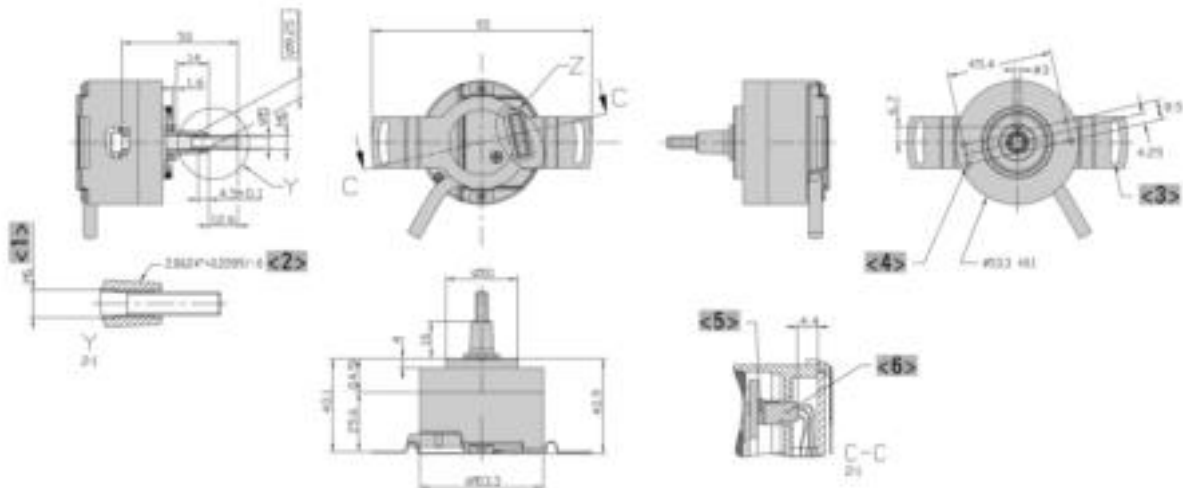

<1> M6 (used for dismounting)

<2> Taper

<3> 3.8 wide slot on a Ø 85 bolt circle (B.C.)

<4> M2.5 x 6 mm DP. (4x)

<5> Cable connector 1

<6> Cable connector 2

Dimensions in mm



AC-Synchronous & BLDC Motors Incremental

OUTPUT WAVEFORMS

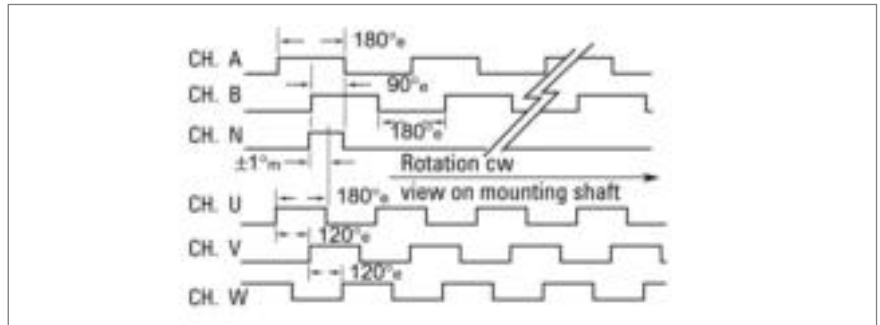

ORDERING INFORMATION

Type	Number of pulses <sup>1,2</sup>	Poles commutation	Spring tether	Electrical <sup>3,4,5,6</sup>	Connection
<input type="checkbox"/>	<input type="checkbox"/>	<input type="checkbox"/>	<input type="checkbox"/>	<input type="checkbox"/>	<input type="checkbox"/>
<b>RF53</b>	<b>0500</b> <b>0512</b> <b>1000</b> <b>1024</b> <b>2000</b> <b>2048</b> <b>2500</b> <b>4096</b> <b>5000</b> <b>8129</b> <b>10E3</b> = 10 000	<b>0</b> Without <b>4</b> 4 pole <b>6</b> 6 pole <b>8</b> 8 pole <b>A</b> 10 pole <b>C</b> 12 pole <b>G</b> 16 pole <b>K</b> 20 pole <b>O</b> 24 pole <b>W</b> 32 pole	<b>1</b> Spring tether rear <b>2</b> Spring tether front	<b>0</b> U inc = DC 5 V, output inc = NPN-O.C. <b>3</b> U inc = DC 5 V, output inc = RS422 <b>6</b> U inc = DC 5 V, output inc = RS422, U com = DC 5 V, output com = NPN-O.C. <b>9</b> U inc = DC 5 V, output inc = RS422, U com = DC 5 V, output com = RS422	<b>E</b> Cable, 7 m <b>K</b> Cable, 10 m <b>P</b> Cable, 15 m <b>1</b> Sub-D connector at 3 m cable <b>2</b> Sub-D connector at 5 m cable <b>3</b> Sub-D connector at 10 m cable <b>0</b> PCB connector, 16 pole

<sup>1</sup> Option redundant on request

<sup>2</sup> allowed combinations see available combinations (pulses/poles)

<sup>3</sup> U inc: Supply voltage incremental, U com: Supply voltage commutation (only if commutation selected)

<sup>4</sup> Code Electrical "0": only incremental, <= 2 048/0 (ppr/poles)

<sup>5</sup> Code Electrical "3": only incremental, without commutation

<sup>6</sup> Code Electrical "6", "9": inkremental plus commutation signals

Available combinations (pulses/poles)

Pulses ppr	Number of poles									
	0	4	6	8	10 (=A)	12 (=C)	16 (=G)	20 (=K)	24 (=O)	32 (=W)
0500	X	X	X	X	X	X				
0512	X	X	X	X						
1000	X	X	X	X	X	X				
1024	X	X	X	X		X				
2000	X	X	X	X	X	X				
2048	X	X	X	X	X	X	X	X	X	X
2500	X	X	X	X	X	X				
4096	X	X	X	X	X	X	X	X	X	X
5000	X	X	X	X	X	X				
8192	X	X	X	X	X	X	X	X	X	X
10E3 =10 000	X	X	X	X	X	X				

AC-Synchronous & BLDC Motors Absolute



- For brushless servo motors
- Light duty encoder
- Notched shaft 6 mm
- Mounting Depth: 25 mm
- Up to 17 Bit Resolution
- +120°C operating temperature
- 10,000 rpm continuous operation
- BiSS or SSI interface
- Sinewave 1 Vpp
- Bandwidth 500 kHz



GENERAL INFORMATION

The AD34 is the most compact absolute encoder in class. It is available with a resolution up to 17 Bit Singleturn. The mechanical design consists of two ball bearings and a flexible torque support. The AD34 complements the ACURO-DRIVE series and is appropriate for use within BLDC servo motors with small frame sizes. The AD34 is available with a notched shaft, which saves installation time.

**Notched shaft saves installation cost**

Because of its innovative shaft mounting the AD34 saves work on the motor shaft. A common 6 mm bore on the motor B – side is enough. AD34's notched shaft is inserted in the B side of the motor shaft in one process step.

**Fully digital control loop**

The new and completely digital OptoAsic technology enables the transition to a truly digital drive system. The conventional absolute encoders still have analog sine wave signals for the feedback of speed and position data. The AD34, however, provides fully digital position data up to 17 Bit over the BiSS interface with a variable clock rate up to 10 MHz. BiSS is the only open high speed bidirectional sensor interface available on the market. Backward compatibility to most of the existing drives is realized through the variant with SSI interface together with 2048 sine –cosine periods per revolution.

**Integrated diagnostic system**

The AD34 has an integrated diagnostic system that controls and regulates the internal signals. Maximum motor uptime is achieved through the pre warning in case of any system error or aging effects well before they affect the function of the encoder. A code plausibility check guarantees that the output data represents always the true position. Also the operating temperature can be measured and read out with 8 Bit resolution. If programmable limits are exceeded or under run this is indicated over warn and alarm bits.

TECHNICAL DATA  
mechanical

Housing diameter	37.5 mm
Shaft diameter	6 mm (Notched Shaft)
Flange (Mounting of housing)	Tether
Protection class shaft input (EN 60529)	IP40
Protection class housing (EN 60529)	IP40
Axial endplay of mounting shaft (hubshaft)	± 0.5 mm
Radial runout of mating shaft (hubshaft)	± 0.05 mm

## AC-Synchronous & BLDC Motors Absolute

### TECHNICAL DATA mechanical (continued)

Max. speed	max. 10 000 rpm (continuous), max. 12 000 rpm (short term)
Torque	0.01 Ncm
Moment of inertia	ca. $2.5 \times 10^{-6}$ kgm <sup>2</sup>
Vibration resistance (DIN EN 60068-2-6)	100 m/s <sup>2</sup> (10 ... 2000 Hz)
Shock resistance (DIN EN 60068-2-27)	1000 m/s <sup>2</sup> (6 ms)
Operating temperature	-15 °C ... +120 °C
Storage temperature <sup>1</sup>	-15 °C ... +85 °C
Weight	approx. 80 g (ST)
Connection	Cable, radial PCB connector, 12 pole

<sup>1</sup> due to packing

### TECHNICAL DATA electrical

Supply voltage	DC 5 V -5 %/+10 % or DC 7 - 30 V
Max. current w/o load	50 mA
Resolution singleturn	12 - 17 Bit
Output code	Gray
Drives	Clock and Data / RS422
Incremental signals optional	Sinus-Cosinus 1 Vpp
Number of pulses	2048
3dB limiting frequency	500 kHz
Absolute accuracy	±35"
Repeatability	±7"
Alarm output	Alarm bit (SSI Option), warning bit and alarm bit (BiSS)

### ELECTRICAL CONNECTIONS PCB connector, 12 pole

Color	PIN	Signals
grey	1a	Data
white/green	2a	A +
black	3a	0 V Sensor
red/blue	4a	B +
green	5a	Clock
violet	6a	5 V Sensor
white	1b	DC 5 V/ 7 - 30 V
yellow	2b	Clock
grey/pink	3b	B -
brown	4b	0 V (U <sub>N</sub> )
brown/green	5b	A -
pink	6b	Data

### CONNECTION ENCODER SIDE

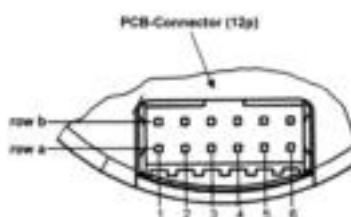

12 pin PCB connector  
manufacture Berg, type Minitex

DIMENSIONED DRAWINGS

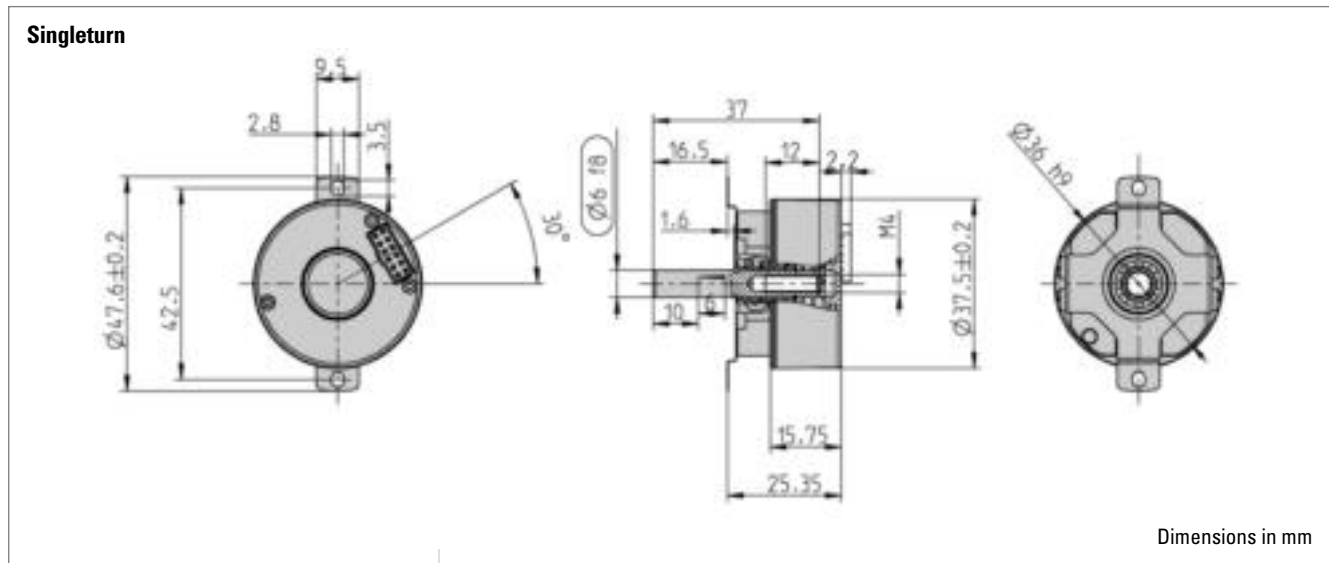

ORDERING INFORMATION

Type	Resolution	Supply voltage <sup>1</sup>	Flange, Protection, Shaft	Interface	Connection
<input type="checkbox"/>	<input type="text"/>	<input type="checkbox"/>	<input type="checkbox"/>	<input type="checkbox"/>	<input type="checkbox"/>
<b>AD34</b>	<b>0012</b> 12 Bit ST <b>0013</b> 13 Bit ST <b>0014</b> 14 Bit ST <b>0017</b> 17 Bit ST	<b>A</b> DC 5 V <b>E</b> DC 7 - 30 V	<b>U.0N</b> Spring tether, IP40, 6mm Notched Shaft	<b>BI</b> BiSS <b>SG</b> SSI Gray <b>SC</b> SSI Gray (+SinCos 1Vpp)	<b>0</b> PCB connector, 12 pole <b>B</b> PCB connector, 12 pole, with mating connector and 0.5 m cable

<sup>1</sup> No inverse-polarity protection for 5 V power supply

AC-Synchronous & BLDC Motors Absolute



- Shortest absolute encoder world wide
- Mounting depth: 23.65 mm
- Hub shaft 8 mm
- Resolution up to 22 Bit Singleturn
- +120°C operating temperature
- 10,000 rpm continuous operation
- BiSS or SSI interface
- Bandwidth 500kHz



GENERAL INFORMATION

Hengstler presents the shortest hollowshaft encoder world wide: The AD35. It is available with a 8 mm hub shaft and a resolution up to 22 Bit Singleturn. The mechanical design consists of two ball bearings and a flexible torque support. The AD35 complements the ACURO-DRIVE series and is appropriate for use within BLDC servo motors with small frame sizes.

Further fields of Application:

- Medical
- Measuring instrument
- Military
- Robotics

Fully digital control loop

The new and completely digital OptoAsic technology enables the transition to a truly digital drive system. The conventional absolute encoders still have analog sine wave signals for the feedback of speed and position data. The AD35, however, provides fully digital position data up to 22 Bit over the BiSS interface with a variable clock rate up to 10 MHz. BiSS is the only open high speed bidirectional sensor interface available on the market. Backward compatibility to most of the existing drives is realized through the variant with SSI interface together with 2048 sine –cosine periods per revolution.

Integrated diagnostic system

The AD35 has an integrated diagnostic system that controls and regulates the internal signals. Maximum motor uptime is achieved through the pre warning in case of any system error or aging effects well before they affect the function of the encoder. A code plausibility check guarantees that the output data represents always the true position. Also the operating temperature can be measured and read out with 8 Bit resolution. If programmable limits are exceeded or under run this is indicated over warn and alarm bits.

TECHNICAL DATA  
mechanical

Housing diameter	37.5 mm
Shaft diameter	8 mm (Hubshaft)
Flange (Mounting of housing)	Tether
Protection class shaft input (EN 60529)	IP40
Protection class housing (EN 60529)	IP40
Axial endplay of mounting shaft (hubshaft)	± 0.5 mm

## AC-Synchronous & BLDC Motors Absolute

### TECHNICAL DATA mechanical (continued)

Radial runout of mating shaft (hubshaft)	± 0.05 mm
Max. speed	max. 10 000 rpm (continuous), max. 12 000 rpm (short term)
Torque	0.01 Ncm
Moment of inertia	ca. $2.5 \times 10^{-6}$ kgm <sup>2</sup>
Vibration resistance (DIN EN 60068-2-6)	100 m/s <sup>2</sup> (10 ... 2000 Hz)
Shock resistance (DIN EN 60068-2-27)	1000 m/s <sup>2</sup> (6 ms)
Operating temperature	-15 °C ... +120 °C
Storage temperature <sup>1</sup>	-15 °C ... +85 °C
Material housing	Plastic
Weight	approx. 80 g (ST)
Connection	Cable, radial PCB connector, 12 pole

<sup>1</sup> due to packing

### TECHNICAL DATA electrical

Supply voltage	DC 5 V -5 %/+10 % or DC 7 - 30 V
Max. current w/o load	50 mA
Resolution singleturn	12 - 22 Bit
Resolution multiturn	12 Bit
Output code	Gray
Drives	Clock and Data / RS422
Incremental signals optional	Sinus-Cosinus 1 Vpp
Number of pulses	2048
3dB limiting frequency	500 kHz
Absolute accuracy	±35"
Repeatability	±7"
Alarm output	Alarm bit (SSI Option), warning and alarm bit (BiSS)

### ELECTRICAL CONNECTIONS PCB connector, 12 pole

Color	PIN	Signals
grey	1a	Data
white/green	2a	A +
black	3a	0 V Sensor
red/blue	4a	B +
green	5a	Clock
violet	6a	5 V Sensor
white	1b	DC 5 V/ 7 - 30 V
yellow	2b	Clock
grey/pink	3b	B -
brown	4b	0 V (U <sub>N</sub> )
brown/green	5b	A -
pink	6b	Data

AC-Synchronous & BLDC Motors Absolute

CONNECTION ENCODER SIDE

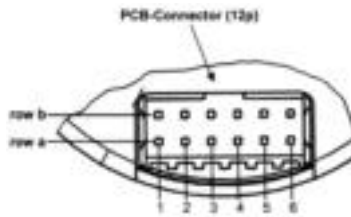

12 pin PCB connector  
manufacture Berg, type Minitek

DIMENSIONED DRAWINGS

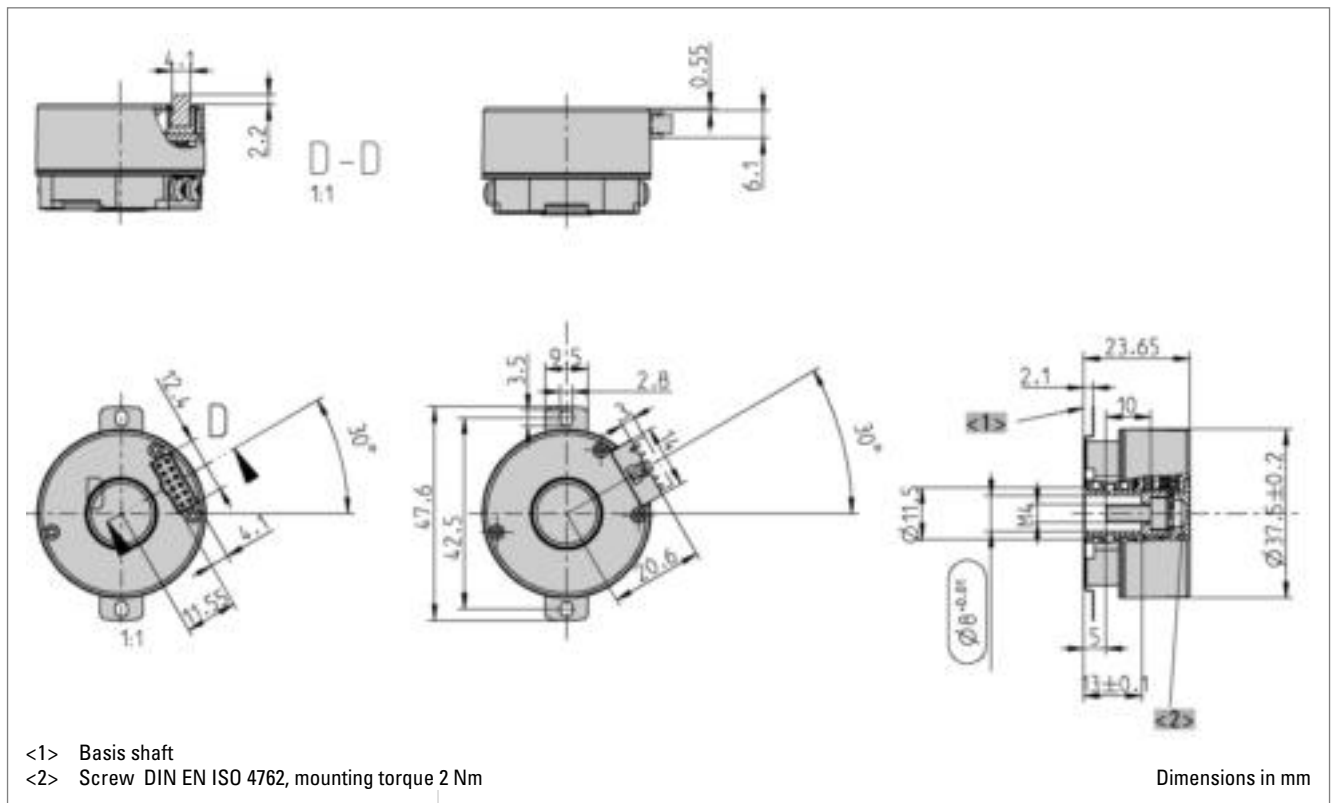

ORDERING INFORMATION

Type	Resolution	Supply voltage <sup>1</sup>	Flange, Protection, Shaft	Interface	Connection
<input type="checkbox"/>	<input type="checkbox"/>	<input type="checkbox"/>	<input type="checkbox"/>	<input type="checkbox"/>	<input type="checkbox"/>
<b>AD35</b>	<b>0012</b> 12 Bit ST <b>0013</b> 13 Bit ST <b>0014</b> 14 Bit ST <b>0017</b> 17 Bit ST <b>0019</b> 19 Bit ST (BiSS) <b>0022</b> 22 Bit ST (BiSS)	<b>A</b> DC 5 V <b>E</b> DC 7 - 30 V	<b>F.0R</b> Spring tether, IP40, 8 mm hub shaft	<b>BI</b> BiSS <b>SG</b> SSI Gray <b>SC</b> SSI Gray (+SinCos 1Vpp)	<b>0</b> PCB connector, 12 pole <b>B</b> PCB connector, 12 pole, with mating connector and 0.5 m cable

<sup>1</sup> No inverse-polarity protection for 5 V power supply

AC-Synchronous & BLDC Motors Absolute



- For brushless servo motors
- Resolver size 15 compatible
- Through hollow shaft 8 mm
- 19 Bit Singleturn + 12 Bit Multiturn
- +120°C operating temperature
- 10,000 rpm continuous operation
- Optical encoder with a true geared multiturn
- BiSS or SSI interface
- Sinewave 1 Vpp
- Bandwidth 500 kHz



GENERAL INFORMATION

The AD36 is an absolute encoder with a true geared Multiturn, optical sensing technology and 36 mm diameter. Unique is the through hollow shaft which enables an assembly that is compatible with resolver size 15. The mechanical design consists of two ball bearings and a flexible torque support. The AD36 complements the **ACURO-DRIVE** series and is appropriate for use within BLDC servo motors with small frame sizes.

Fully digital control loop

The new and completely digital OptoAsic technology enables the transition to a truly digital drive system. The conventional absolute encoders still have analog sine wave signals for the feedback of speed and position data. The AD36, however, provides fully digital position data up to 19 Bit (Singleturn) and 12 Bit (Multiturn) over the BiSS interface with a variable clock rate up to 10 MHz. BiSS is the only open high speed bidirectional sensor interface available on the market. Backward compatibility to most of the existing drives is realized through the variant with SSI interface together with 2048 sine – cosine periods per revolution.

Integrated diagnostic system

The AD36 has an integrated diagnostic system that controls and regulates the internal signals. Maximum motor uptime is achieved through the pre warning in case of any system error or aging effects well before they affect the function of the encoder. A code plausibility check guarantees that the output data represents always the true position. Also the operating temperature can be measured and read out with 8 Bit resolution. If programmable limits are exceeded or under run this is indicated over warn and alarm bits.

TECHNICAL DATA  
mechanical

Housing diameter	37.5 mm
Shaft diameter	8 mm (Through hollow shaft) 8 mm (Hubshaft)
Flange (Mounting of housing)	Tether
Protection class shaft input (EN 60529)	IP40
Protection class housing (EN 60529)	IP40
Axial endplay of mounting shaft (hubshaft)	± 0.5 mm
Radial runout of mating shaft (hubshaft)	± 0.05 mm
Max. speed	max. 10 000 rpm (continuous), max. 12 000 rpm (short term)
Torque	0.01 Ncm



## AC-Synchronous & BLDC Motors Absolute

### TECHNICAL DATA mechanical (continued)

Moment of inertia	ca. $2.5 \times 10^{-6} \text{ kgm}^2$
Vibration resistance (DIN EN 60068-2-6)	100 m/s <sup>2</sup> (10 ... 2000 Hz)
Shock resistance (DIN EN 60068-2-27)	1000 m/s <sup>2</sup> (6 ms)
Operating temperature	-15 °C ... +120 °C
Storage temperature <sup>1</sup>	-15 °C ... +85 °C
Weight	approx. 80 g (ST) / 130 g (MT)
Connection	Cable, radial PCB connector, 12 pole

<sup>1</sup> due to packing

### TECHNICAL DATA electrical

Supply voltage	DC 5 V -5 %/+10 % or DC 7 - 30 V
Max. current w/o load	50 mA (ST), 100 mA (MT)
Resolution singleturn	12 - 19 Bit (BiSS) 12 - 17 Bit (SSI)
Resolution multiturn	12 Bit
Output code	Gray
Drives	Clock and Data / RS422
Incremental signals optional	Sinus-Cosinus 1 Vpp
Number of pulses	2048
3dB limiting frequency	500 kHz
Absolute accuracy	±35"
Repeatability	±7"
Alarm output	Alarm bit (SSI Option), warning and alarm bit (BiSS)

### ELECTRICAL CONNECTIONS PCB connector, 12 pole

Color	PIN	Signals
grey	1a	Data
white/green	2a	A +
black	3a	0 V Sensor
red/blue	4a	B +
green	5a	Clock
violet	6a	5 V Sensor
white	1b	DC 5 V / 7 - 30 V
yellow	2b	Clock
grey/pink	3b	B -
brown	4b	0 V (U <sub>N</sub> )
brown/green	5b	A -
pink	6b	Data

### CONNECTION ENCODER SIDE

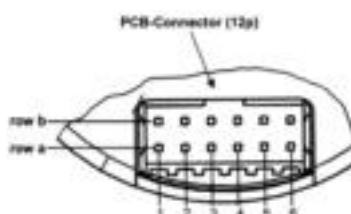

12 pin PCB connector  
manufacture Berg, type Minitek

DIMENSIONED DRAWINGS

Hubshaft

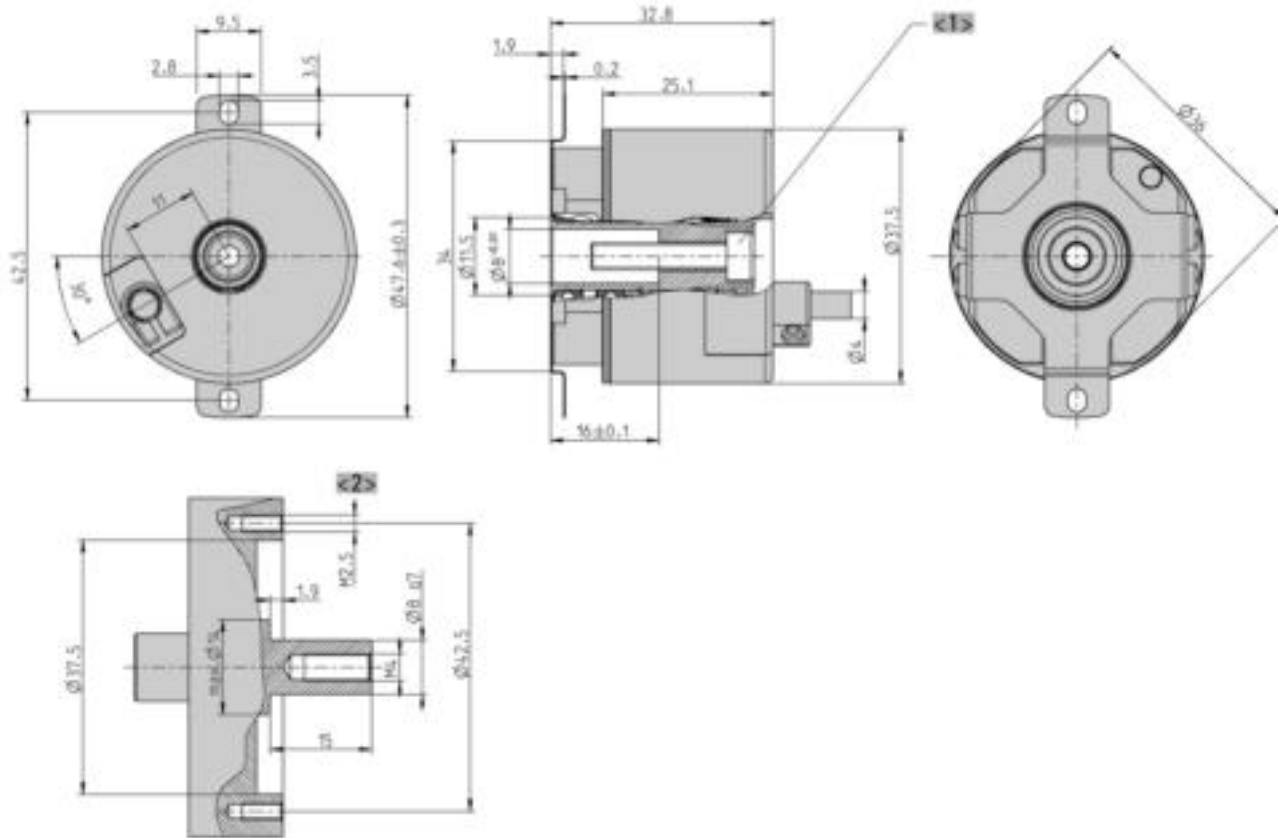

<1> ISO 4762 M4x20

<2> Mounting hollow shaft

Dimensions in mm

Through hollow shaft

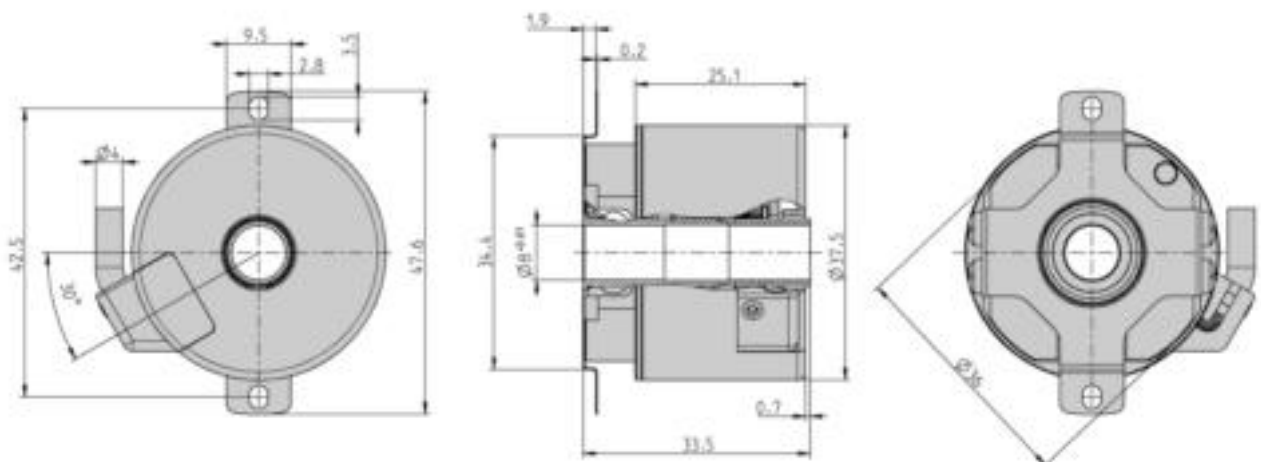

Dimensions in mm

**AC-Synchronous & BLDC Motors Absolute**

**ORDERING INFORMATION**

Type	Resolution	Supply voltage	Flange, Protection, Shaft	Interface	Connection
<input type="checkbox"/>	<input type="text"/>	<input type="checkbox"/>	<input type="checkbox"/>	<input type="checkbox"/>	<input type="checkbox"/>
<b>AD36</b>	<b>0012</b> 12 Bit ST <b>0013</b> 13 Bit ST <b>0014</b> 14 Bit ST <b>0017</b> 17 Bit ST <b>0019</b> 19 Bit ST (BiSS) <b>1213</b> 12 Bit MT + 13 Bit ST <b>1217</b> 12 Bit MT + 17 Bit ST <b>1219</b> 12 Bit MT + 19 Bit ST (BiSS)	<b>A</b> DC 5 V <b>E</b> DC 7 - 30 V	<b>F.0C</b> Spring tether, IP40, 8 mm trough hollow shaft <b>F.0R</b> Spring tether, IP40, 8 mm hub shaft	<b>BI</b> BiSS <b>SC</b> SSI Gray (+SinCos 1Vpp)	<b>0</b> PCB connector, 12 pole <b>B</b> PCB connector, 12 pole, with mating connector and 0.5 m cable

**ACCESSORIES**

see chapter "Accessories", starting page 322

AC-Synchronous & BLDC Motors Absolute



- For brushless servo motors
- All-digital and highspeed
- +120°C operating temperature
- 10,000 rpm continuous operation
- Optical encoder with a true geared multiturn
- BiSS or SSI interface
- Option Sinewave 1 Vpp: Harmonic distortion less than 1%
- Bandwidth 500 kHz



GENERAL INFORMATION

The AD58 is an absolute encoder with a true geared Multiturn and optical sensing technology: The mechanical design consists of two ball bearings and a flexible torque support. The AD58 is ideally suited for integration into BLDC servo motors for demanding applications such as CNC precision machining and printing in professional quality. Through its low current consumption the AD58 is contributing to lowering cost of ownership.

Fully digital control loop

The new and completely digital OptoAsic technology enables the transition to a truly digital drive system. The conventional absolute encoders still have analog sine wave signals for the feedback of speed and position data. The AD 58, however, provides fully digital position data up to 22 Bit (Singleturn) and 12 Bit (Multiturn) over the BiSS interface with a variable clock rate up to 10 MHz. This corresponds a singleturn resolution of morethan 4 million measured steps.

TECHNICAL DATA  
mechanical

Housing diameter	58 mm
Shaft diameter	10 mm (Cone hollow shaft) 10 mm (Cone solid shaft)
Flange (Mounting of housing)	Tether
Protection class shaft input (EN 60529)	IP40
Protection class housing (EN 60529)	IP40
Axial endplay of mounting shaft (hubshaft)	± 0.5 mm
Radial runout of mating shaft (hubshaft)	± 0.1 mm
Max. speed	max. 10 000 rpm (continuous), max. 12 000 rpm (short term)
Torque	0.01 Ncm
Moment of inertia	ca. 3.8 x 10 <sup>-6</sup> kgm <sup>2</sup>
Vibration resistance (DIN EN 60068-2-6)	100 m/s <sup>2</sup> (10 ... 2000 Hz)
Shock resistance (DIN EN 60068-2-27)	1000 m/s <sup>2</sup> (6 ms)
Operating temperature	-15 °C ... +120 °C
Storage temperature <sup>1</sup>	-15 °C ... +85 °C
Weight	approx. 260 g (ST) / 310 g (MT)
Connection	PCB connector, 12 pole

AC-Synchronous & BLDC Motors Absolute

TECHNICAL DATA  
mechanical (continued)

TECHNICAL DATA  
electrical

<sup>1</sup> due to packing

Supply voltage	± 10% DC 5 V or DC 10 - 30 V
Max. current w/o load	50 A (ST), 100 A (MT)
Resolution singleturn	13 Bit (SSI) max. 22 Bit (BiSS)
Resolution multiturn	12 Bit
Output code	Binary, Gray
Incremental signals optional	Sinus-Cosinus 1 Vpp
Number of pulses	2048
3dB limiting frequency	500 kHz
Absolute accuracy	±35"
Repeatability	±7"
Parametrization	Resolution, Code type, Direction, Warning, Alarm
Alarm output	Alarm bit (SSI Option), warning and alarm bit (BiSS)

ELECTRICAL CONNECTIONS  
PCB connector, 12 pole

Colour	PIN	Signals
violet	1a	$\overline{\text{Data}}$
green	2a	A+
brown/green	3a	0 V Sensor
blue	4a	B+
brown	5a	$\overline{\text{Clock}}$
red/blue	6a	5 V Sensor
green/pink	1b	DC 5 V/ 7 -30 V
white	2b	Clock
red	3b	B-
white/green	4b	0 V (U <sub>N</sub> )
yellow	5b	A-
black	6b	Data

CONNECTION ENCODER SIDE



12 pin PCB connector  
manufacture Berg, type Minitex  
Screen is connected over a  
length of 10 mm with  
encoder housing.

AC-Synchronous & BLDC Motors Absolute

DIMENSIONED DRAWINGS

<1> Central mounting screw, Singleturn: DIN 912 M5x50  
 <1> Central mounting screw, Multiturn: DIN 912 M5x65

Shaft code: "K"  
 Flange code: "T" (with tether), "O" (without tether)

Dimensions in mm

ORDERING INFORMATION

Type	Resolution	Supply voltage	Flange, Protection, Shaft	Interface	Connection
<input type="checkbox"/>	<input type="checkbox"/>	<input type="checkbox"/>	<input type="checkbox"/>	<input type="checkbox"/>	<input type="checkbox"/>
<b>AD58</b>	<b>0013</b> 13 Bit ST <b>0022</b> 22 Bit ST (BiSS) <b>1213</b> 12 Bit MT + 13 Bit ST <b>1222</b> 12 Bit MT + 22 Bit ST (BiSS)	<b>A</b> DC 5 V <b>E</b> DC 10 - 30 V	<b>1.0K</b> Spring tether, IP40, cone 10 mm	<b>BI</b> BiSS <b>SC</b> SSI Gray (+SinCos 1Vpp)	<b>0</b> PCB connector, 12 pole <b>B</b> PCB connector, 12 pole, with mating connector and 0.5 m cable

ACCESSORIES

see chapter "Accessories", starting page 322

AC-Synchronous & BLDC Motors Sine-wave



- Wide operating temperature range of -15 °C up to +120 °C, therefore optimum use of motor capacity
- High limiting frequency with excellent signal quality, allowing highest peak speeds and reduced non-productive time wastage
- Excellent immunity to interference (EN 61000-4-4, Class 4)
- High functional safety due to signal control and system monitoring (under-voltage, pollution, disc damage, end of LED service life)
- High signal quality through control and error compensation



**TECHNICAL DATA**  
mechanical

Housing diameter	53 mm
Shaft diameter	Cone 1/10
Protection class shaft input (EN 60529)	IP40
Protection class housing (EN 60529)	IP40
Shaft load axial / radial	for tapered solid shaft: 20 N / 90 N
Axial endplay of mounting shaft (hubshaft)	± 0.5 mm
Radial runout of mating shaft (hubshaft)	± 0.1 mm
Max. speed	max. 12 000 rpm (continuous), max. 15 000 rpm (short term)
Torque	≤ 1 Ncm
Vibration resistance (DIN EN 60068-2-6)	≤ 100 m/s <sup>2</sup> (10 ... 2,000 Hz)
Shock resistance (DIN EN 60068-2-27)	≤ 1,000 m/s <sup>2</sup> (6 ms)
Operating temperature	-15 °C ... +120 °C
Storage temperature	-20 °C ... +80 °C
Material housing	Aluminum
Weight	approx. 170 g
Connection	PCB connector and cable

**TECHNICAL DATA**  
electrical

General design	as per DIN EN 61010-1, protection class III, contamination level 2, overvoltage class II
Supply voltage	DC 5 V ±10 %
Max. current w/o load	120 mA
Reference signal R	> 0.4 V (1 pulse per revolution)
Commutation signals C, D	Sine - Cosine 1 Vpp (1 period per rev.)
Incremental signals optional	Sinus-Cosinus 1 Vpp
Number of pulses	2048
3dB limiting frequency	500 kHz
Absolute accuracy	±35"
Repeatability	±7"

AC-Synchronous & BLDC Motors Sine-wave

S 21 SIGNALS

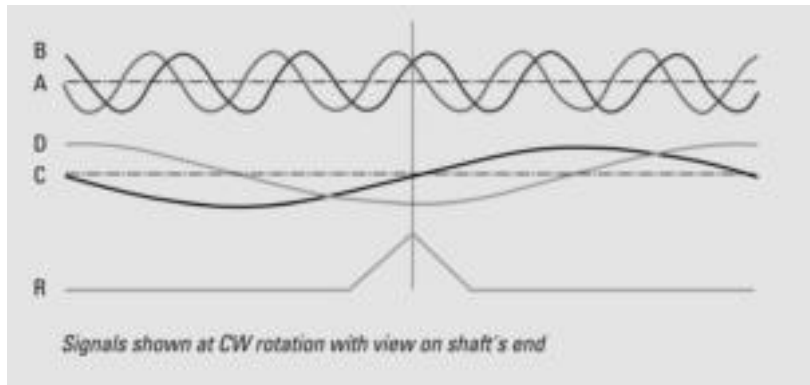

The incremental signals A and B and the zero signal R are differential voltage signals. The differential signal level is 1 Vpp. The zero signal appears once per revolution and reaches its maximum value at the angle where the amplitudes of A and B Signals are equal. The coarse tracks C and D deliver one sinewave period per revolution and are utilized to determine the absolute rotor position of Brushless DC motors for startup commutation. All signals have a DC offset of 2.5 V.

S 21 SIGNAL QUALITY

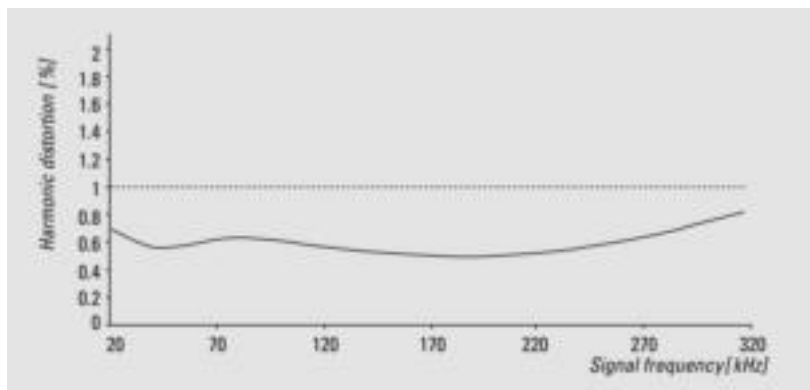

The quality of the servo loop is determined to a large extent by the absence of harmonics in the encoder's sinewave signals, particularly at low speed. In order to achieve high interpolation factors in the sequencing control, the incremental sinewave signals A and B are available with a harmonic distortion significantly under 1% throughout the specified temperature range. This delivers excellent synchronism and a high level of positional accuracy with servo axes.



AC-Synchronous & BLDC Motors Sine-wave

ELECTRICAL CONNECTIONS  
PCB connector

Colour	PIN	Signals
brown	1a	C-
grey/pink	1b	U <sub>B</sub>
yellow	2a	A-
black	2b	D+
green/brown	3a	0 V Sense
blue	3b	B+
pink	4a	R-
grey	4b	R+
red	5a	B-
white/green	5b	GND
violet	6a	D-
green	6b	A+
red/blue	7a	DC 5 V Sense
white	7b	C+

DIMENSIONED DRAWINGS

Tapered solid shaft

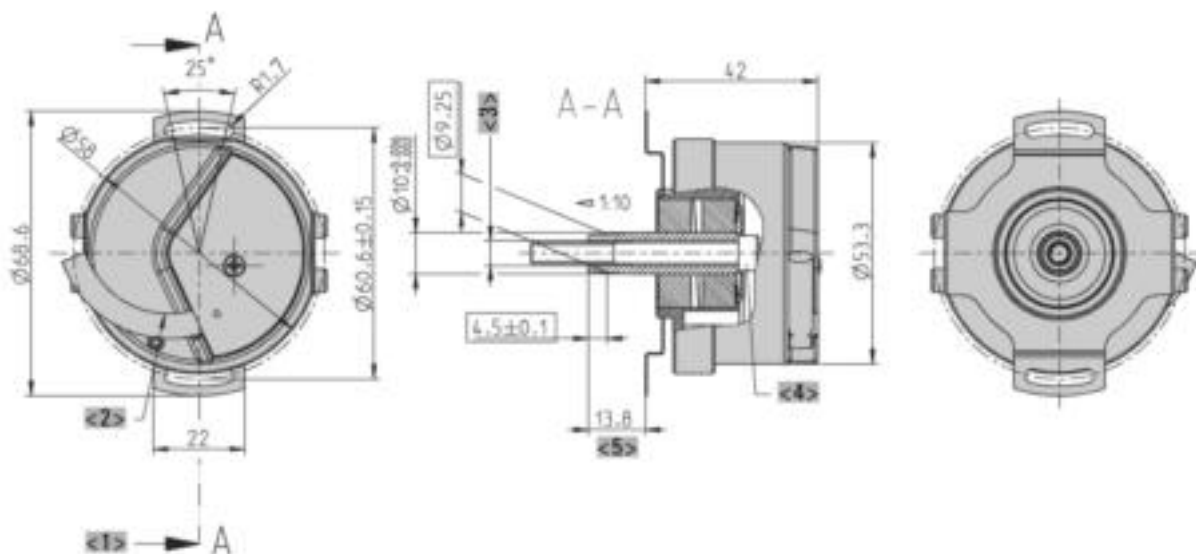

- <1> Shaft exterior
- <2> Cable bending radius  $R \geq 24\text{mm}$  (for fixed installation)
- <3> M6 jack-out thread

- <4> Central mounting screw DIN 912 M5x20
- <5> Mounting dimensions spring tether on shaft

Dimensions in mm

ORDERING INFORMATION

	Ordering code
Tapered solid shaft with mounting support	0 548 011

ACCESSORIES

see chapter "Accessories", starting page 322



## GENERAL INFORMATION

- Provide accurate, absolute position feedback
- Rugged and able to withstand high shock and vibration levels
- Impervious to most industrial contaminant and temperature extremes
- High temperature up to 220°C
- Operation in non electroconductive liquids possible
- Maintenance-free (brushless)
- Aging resistant (no electronic components)
- Low-priced
- Applications: Servo drives, medical technologie (sterilisable), robots, gearless drives, military engineering

Brushless resolvers are the ideal rotor position indicators for the position feedback of brushless motors, robots or direct drives. They are robust, reliable and suitable for high operating temperatures until 155 °C and resistant to most process liquids, contaminations, radiation and EMC-Interferences as well as highly shock-proof and vibration-resistant. These resolvers deliver absolute position information and can be combined with low cost integrated circuits, to generate an up to 16 bit digital position-value or, to produce an emulated incremental encoder output signal, as well as direction and analogue speedsignals.

## DIMENSIONED DRAWINGS

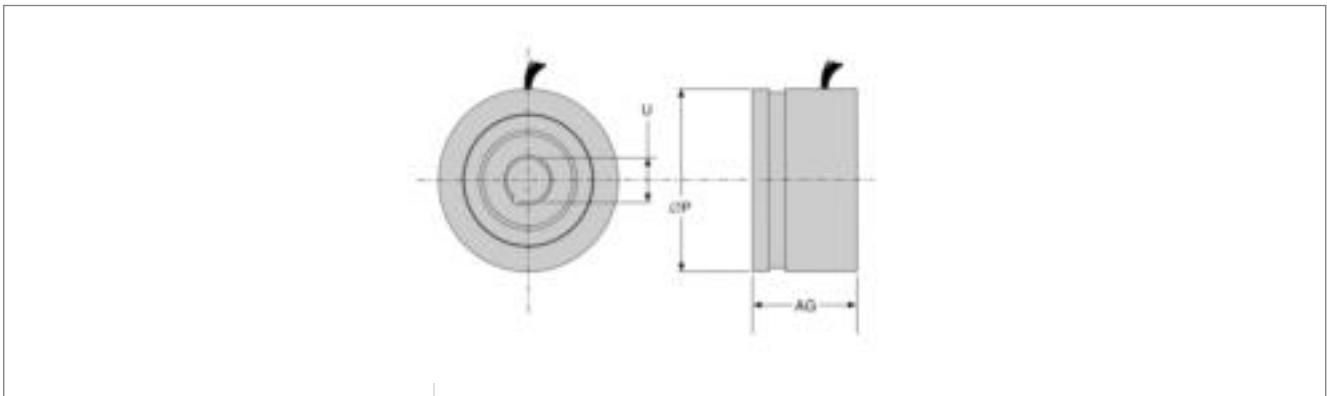

## OVERVIEW TYPES (models)

Type (model)	AG	P	U maximal
10BRCX	16.5 mm	26.5 mm	6.0 mm
15BRCX	25.4 mm	36.8 mm	12.0 mm
21BRCX	31.8 mm	52.4 mm	20.3 mm
31BRCX	31.8 mm	77.5 mm	40.0 mm
55BRCX	31.8 mm	139.7 mm	92.7 mm

### Ordering information:

Since resolvers are produced according to special applications, the production takes place only in big batch sizes. For replacement needs, please contact your drive-manufacturer.



### Housed Resolvers Series R11

- Brushless construction
- Rugged housing
- Maintenance free
- Able to withstand high shock and vibration levels
- Insensitive to most industrial contaminant and temperature extremes
- High temperature up to 115°C

Housed Resolvers distinguish themselves through high reliability in harsh environments, operating temperatures up to 155 °C and high shock resistance. Based on their brushless design they are the ideal supplement to brushless servo motors. The accuracy as well as the repeatability are excellent. These resolvers are equipped with precision bearings and are maintenance-free. They are also the shortest resolvers, that are available on the market.

### DIMENSIONED DRAWINGS

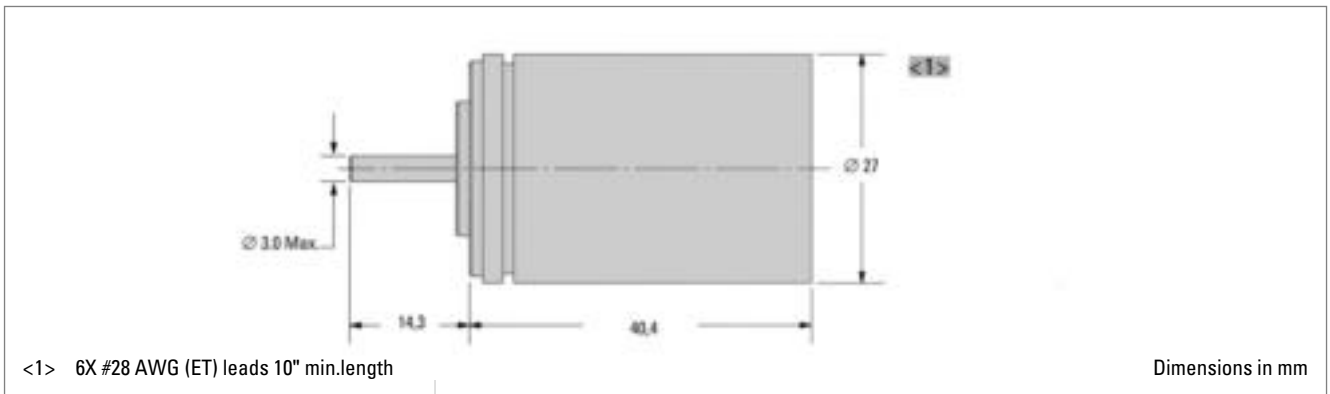

### Housed Resolvers Industry Series R25

- Rugged housing with IP65
- Able to withstand high shock and vibration levels
- Insensitive to most industrial contaminant and temperature extremes
- High temperature up to 125°C
- Flange- and servo-mount styles

Industry resolvers possess especially robust casings with protection class IP65. They are especially suitable for the use with high temperatures (+125 °C in long-term operation), and offer extraordinary values of vibration and shock resistance (40g as well as 200g), as well as noise immunity. The user is flexible in the application because of the corrosion resistant versions for integration or extension, the connection could easily be done by Standard MS-style connectors. The accuracy has a spread of  $\pm 7$  up to  $\pm 200$  arc-minutes.

### DIMENSIONED DRAWINGS

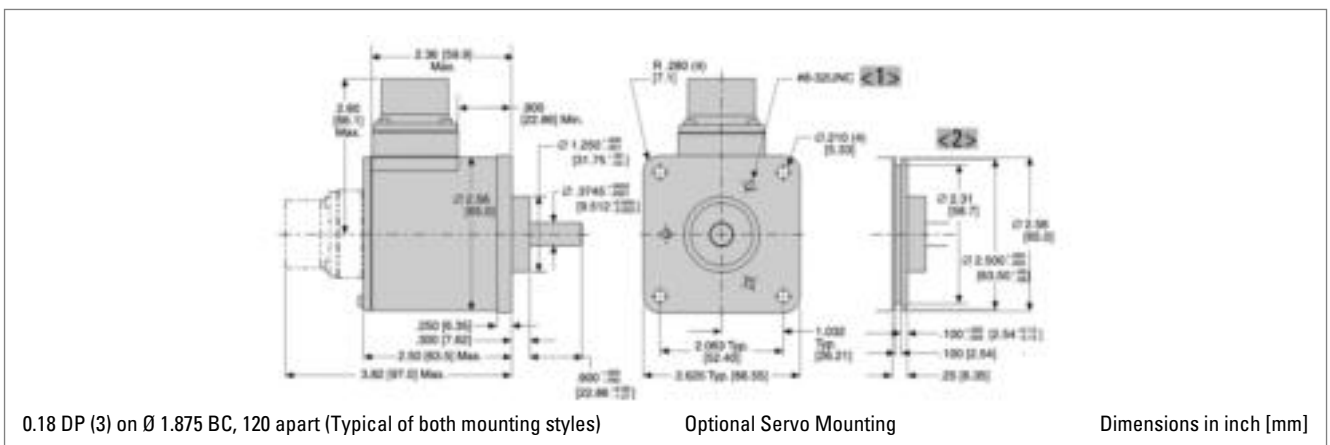

## Accessories

### **Problem solutions from a single source.**

Our wide range of accessory modules completes the encoder programme.

With these modules, we offer you an optimum means of meeting your application demands.

# for Absolute Encoder Connection



- Large, 6-digit, 14 mm high LED display
- Predetermined offset
- 2 variable limit values
- Easy direct selection by 2 function keys
- Relay outputs with change-over contacts
- Chain value or absolute value indication
- npn/pnp programming of inputs
- Synchronous Serial Interface

## APPLICATION FIELDS

Indication of infeed values, lengths, support- or machine positions, totalizing values etc. The coupling to the machine may be done with an absolute encoder with SSI-Interface from the wide and comprehensive Hengstler program of types AC 58.

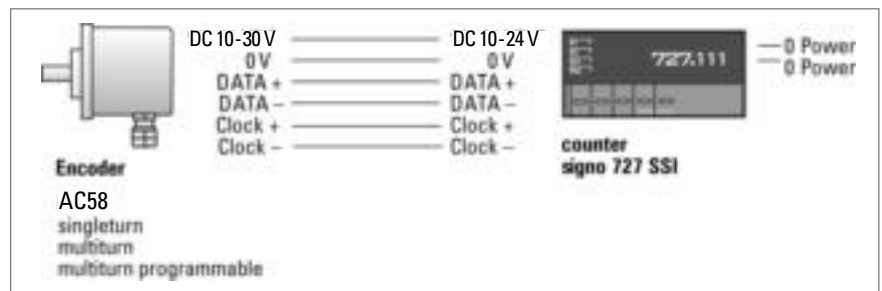

## DISPLAY



- Section A:** shows the actual count value when in counting mode, and the changeable parameters when in programming mode.
- Section B:** LED indicators showing the active output signal, and in programming mode indicating the changeable parameter.

## PROGRAMMING

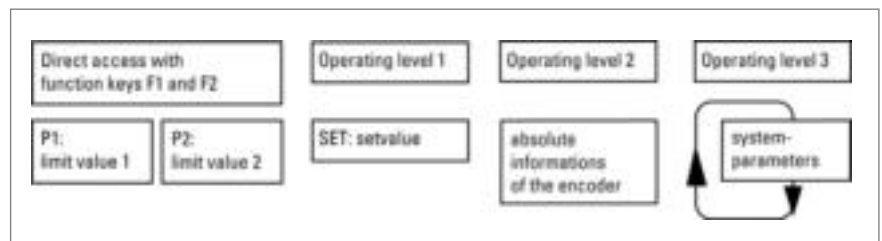

Programming of signo 727 is possible by direct access and in the 3 operating levels

- Direct access:** Limit values are set with the function keys F1, F2
- Operating level 1:** Set value
- Operating level 2:** Includes absolute informations of the encoder
- Operating level 3:** Includes system parameters, which are normally programmed during start-up procedure only.

Unauthorized programming of the signo 727 is prevented by a control input, which can lock the operating levels.

## for Absolute Encoder Connection

## TECHNICAL DATA

Display	LED, indication value/preselection 6 digits, suppression of leading zeros, programmable decimal point, minus sign
Digit Height	14 mm
Power Supply Voltage $U_B$	DC 12 ... 24 V or AC 115/230 V, depending on version
Max. current w/o load	DC 12 ... 24 V < 250 mA, AC 115/230 V < 60 mA
Sensor Supply	AC operation DC 12...24 V, DC operation $U_B - 2 V$ , $I_{max} = 60 mA$
Data Retention	non-volatile memory > 10 years
Operating Temperature	0 ... 50° C
Storage Temperature	-20 ... +70° C
Electrical Connection	plug-in terminals
Mounting	with clamping frame
Protection Class (IEC 144)	front side IP54, terminals IP20
Noise Immunity EMC	severity 3 according to IEC 801, part 2 + part 4
Vibration resistance	10 m/s <sup>2</sup> (10 ... 150 Hz) according to IEC 68-part 2-6
Shock resistance	100 m/s <sup>2</sup> (18 ms) according to IEC 68-part 2-27
General design	according to VDE 0411, DIN 57411, protection class II
Inputs	SSI Data + SSI Data -
Baud rate	approx. 100 kHz
Control Input	Application Input 1, static Display hold, Reset or Chain Reset (programmable)
Keylock	static
Outputs	SSI measure + SSI measure -
Relay <sup>1</sup>	Out 1 and Out 2
Contact Type	changeover relay
Switching Voltage	max. 250 VAC/30 VDC, mind 5 VAC/DC
Switching Current	max. 1A, min. 10 mA

<sup>1</sup> for versions with limit values only

for Absolute Encoder Connection

DIMENSIONAL DRAWINGS

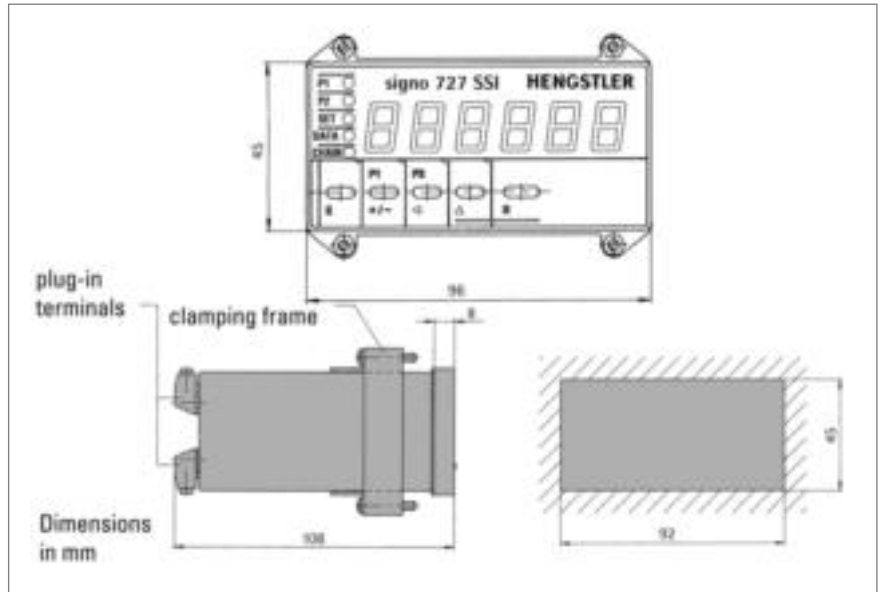

CONNECTION PLAN

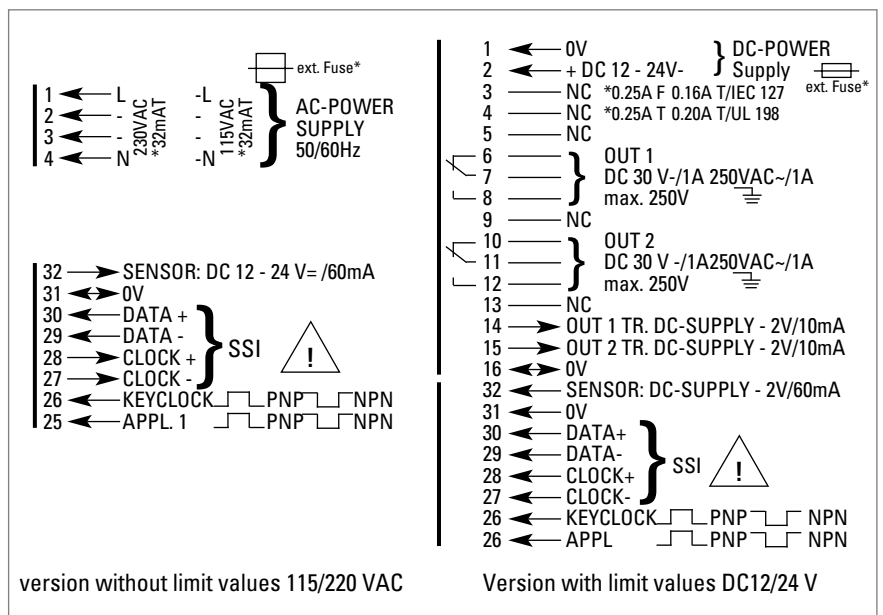

ORDERING DATA

Type	Absolute encoder connection	Supply	Ordering code
signo 727 without limit values	SSI	DC 12 - 24 V	<b>0 727 111</b>
signo 727 without limit values	SSI	AC 115/230 V	<b>0 727 112</b>
signo 727 with 2 limit values	SSI	DC 12 - 24 V	<b>0 727 131</b>
signo 727 with 2 limit values	SSI	AC 115/230 V	<b>0 727 132</b>

opt. with interface RS 485, RS 232 on request

Please note:

Absolute encoders with capped Gray Code (e.g. 360 or 720) must not be connected  
 Max. encoder resolution: 12 Bit ST (singleturn) and  
 24 Bit MT (multiturn 12 + 12 Bit)

## Encoder with Shock Module

### AC58-S/M/P WITH OPTIONAL SHOCK MODULE

Applications with vibration rates of up to  $>100 \text{ m/s}^2$  and shock rates  $>1000 \text{ m/s}^2$  require the use of a shock module. By means of integrated attenuating elements, these encoder ratings are reduced.

Fixing	flange by means of clamping flange or clamping eccentric, shaft by means of flexible coupling
Absolute max. shaft load	axial 30 N, radial 100 N
Shaft diameter	10 mm

### DIMENSIONAL DRAWING ENCODER WITH SHOCK MODULE, CONNECTING CABLE

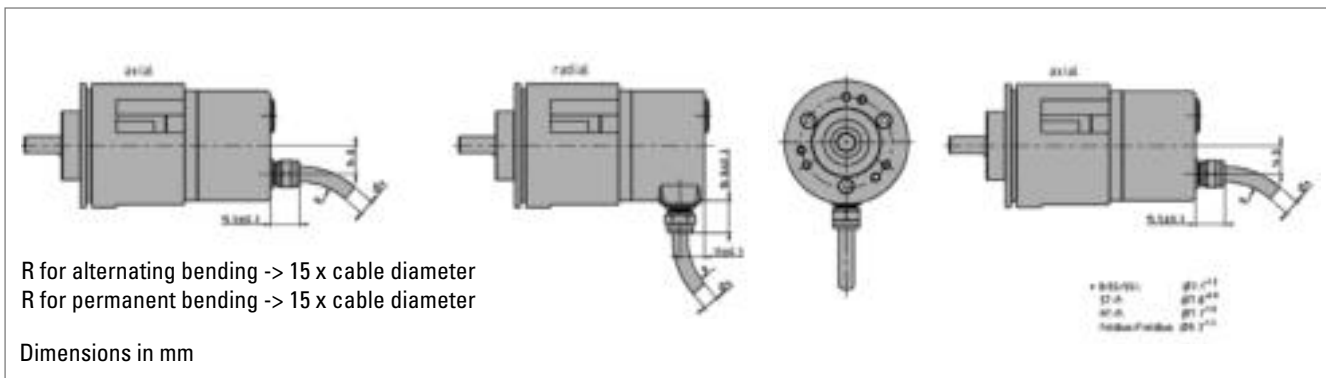

### DIMENSIONAL DRAWING ENCODER WITH SHOCK MODULE, FLANGE CONNECTOR

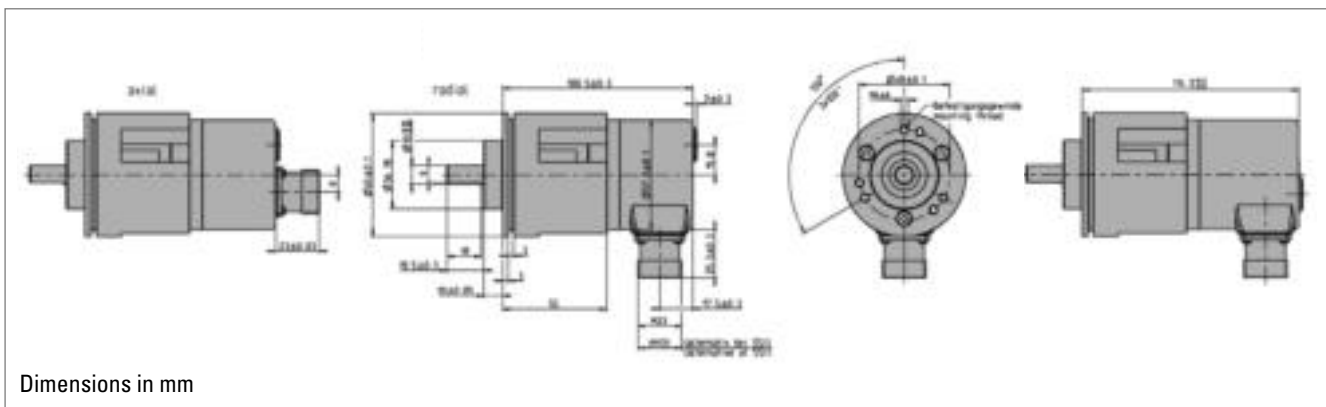

### ORDERING DATA

For the encoder option with shock module, please enquire by stating your desired encoder type.

(Accessories unit 1 540 239  
Flange ordering code: L.42 for RI 58, K.42 for AC 58)



# Flexible Couplings

Shaft encoders must be protected against excessive mechanical stresses, which occur whenever there are angular, axial, or radial misalignments between the machine and shaft encoder shafts.

Our flexible couplings can compensate for this within limits.



## PLASTIC COUPLING

Max. speed	10 000 min <sup>-1</sup>
Torque max.	20 Ncm
Moment of inertia	1.1 gcm <sup>2</sup>
Torsional spring constant	12 Nm/rad
Max. angular misalignment	±2.5°
Max. shaft misalignment radial / axial	±0.3 mm / ±0.2 mm
Max tightening torque of set screws	70 Ncm
Material	polyamide 6.6 glass-fibre reinforced
Weight approx.	6 g

### Plastic coupling

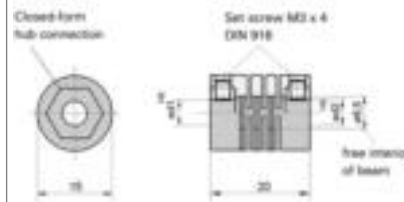

Dimensions in mm

Hub diameter

5/5 mm	Ordering code <b>3 520 034</b>
5/6 mm	Ordering code <b>3 520 033</b>
6/6 mm	Ordering code <b>1 761 026</b>

Suitable for encoder type RI 39  
RI 32, RI 41, RI 42 for simple applications



## HELICAL COUPLING

Max. speed	6 000 min <sup>-1</sup>
Torque max.	80 Ncm
Moment of inertia	8.7 gcm <sup>2</sup>
Torsional spring constant	14 Ncm/degree
Max. angular misalignment	±4°
Max. shaft misalignment radial/axial	±0.25 mm / ±0.4 mm
Max tightening torque of set screws	80 Ncm
Material	AlCuMgPb, chromed
Weight	16 g

### Helical coupling 19/28

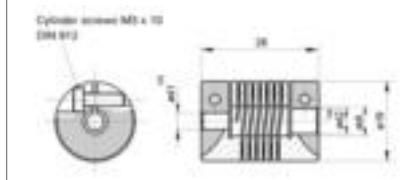

Dimensions in mm

Hub diameter	
5/5 mm	Ordering code <b>3 520 036</b>
5/6 mm	Ordering code <b>3 520 035</b>
6/6 mm	Ordering code <b>0 070 653</b>
6/6.35 mm	Ordering code <b>3 520 051</b>
6.35/6.35 mm	Ordering code <b>3 520 057</b>

Suitable for encoder type RI 30, RI 32,  
RI 36, RI 41, RI 42, RI 58, AC 58

### Helical coupling 25/32

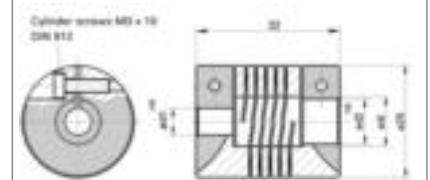

Dimensions in mm

Hub diameter	
6/9.53 mm	Ordering code <b>3 520 052</b>
6/10 mm	Ordering code <b>3 520 066</b>
6.35/9.52 mm	Ordering code <b>3 520 062</b>
10/12 mm	Ordering code <b>3 520 065</b>
10/10 mm	Ordering code <b>3 520 074</b>

Suitable for encoder type RI 58, AC 58

## Flexible Couplings



### ISOLATED DISK COUPLING

Max. speed		12 000 min <sup>-1</sup>
Torque max.		60 Ncm
Max. shaft misalignment	radial	±0.3 mm
	axial	±0.4 mm
	angular	±2.5°
Torsional spring constant		30 Nm/rad
Material	Flanges	aluminium, anodized
	Spring disc	plastic, glass-fibre reinforced

#### Hub diameter

5/6 mm	Ordering code <b>3 520 080</b>	Suitable for encoder type RI 30, RI 32, RI 36, RI 41, RI 42, RI 58, AC 58
6/6 mm	Ordering code <b>3 520 081</b>	
6/10 mm	Ordering code <b>3 520 082</b>	
6/6.35 mm	Ordering code <b>3 520 083</b>	
6/9.53 mm	Ordering code <b>3 520 084</b>	
6.35/6.35 mm	Ordering code <b>3 520 085</b>	
7/7 mm	Ordering code <b>3 520 086</b>	
10/6.35 mm	Ordering code <b>3 520 087</b>	
10/10 mm	Ordering code <b>3 520 088</b>	



### DISK COUPLING

Max. speed		12 000 min <sup>-1</sup>
Torque max.		80 Ncm
Moment of inertia		19 gcm <sup>2</sup>
Torsional spring constant		150 Nm/rad
Max. angular misalignment		±3.0°
Max. shaft misalignment	radial	±0.4 mm
	axial	±0.4 mm
Max tightening torque of set screws		80 Ncm
Hub diameter d and d <sub>1</sub>		6 mm H 8
Material	coupling body, flange	AlCuMgPb, anodized
	preloaded disc	stainless steel
Weight approx.		14.5 g

Ordering code **0 070 663** suitable for encoder type RI 36, RI 58, AC 58

### DIMENSIONAL DRAWINGS

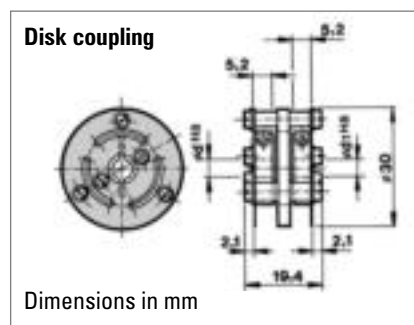
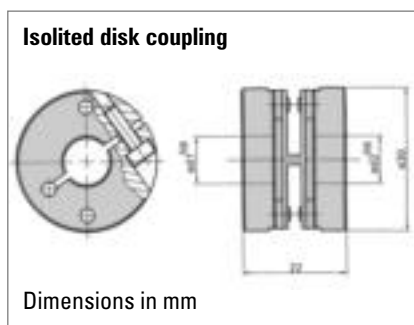

## Flexible Couplings



### BELLOWS COUPLING

Max. speed		8000 min <sup>-1</sup>
Torque max.		80 Ncm
Moment of inertia		9 gcm <sup>2</sup>
Torsional spring constant		140 Nm/rad
Max. angular misalignment		±4.0°
Max. shaft misalignment	radial	±0.3 mm
	axial	±0.5 mm
Max tightening torque of set screws		150 Ncm
Material	flange	aluminium
	bellows	stainless steel
Weight		16 g

#### Hub diameter

12/12 mm

Ordering code **0 070 666**

Suitable for type RI 58, AC 58

10/10 mm

Ordering code **3 520 037**

9.53/9.53 mm

Ordering code **3 520 038**

6/6 mm

Ordering code **3 520 068**

### DIMENSIONAL DRAWING

#### Bellows coupling

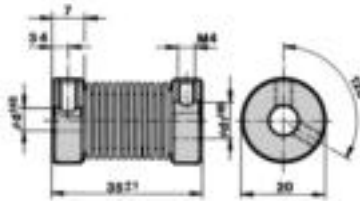

Dimensions in mm

# Mounting

## CLAMPING ECCENTRIC

	$\varnothing d_1$	$\varnothing d_2$	$\varnothing d_3$	a	b	c
Ordering code <b>0 070 655</b> (RI 58, AC 58) Synchro flange for M3)	8.9 <sup>+0.1</sup>	6.5	3.2	4.9 <sup>-0.1</sup>	2.9 <sup>-0.1</sup>	1.2
Ordering code <b>0 070 657</b> (RI 58, AC 58) Synchro flange for M3)	12	9	3.5	4.9 <sup>-0.1</sup>	2.9 <sup>-0.1</sup>	1.5
Ordering code <b>0 070 654</b> (RI 30, RI 36) Synchro flange for M2.5)	6.8 <sup>+0.2</sup>	5	2.8	4.4 <sup>-0.1</sup>	2.4 <sup>-0.1</sup>	0.9
Ordering code <b>1 522 300</b> (RI 58, AC 58) Synchro flange for M4)	(15)	9.5	4.2	5.4 <sup>-0.1</sup>	2.9 <sup>-0.1</sup>	flattened

Material CuZn39Pb3, surface nickel-plated  
Set of three  
Suitable for encoders with synchro flange  
type RI 30, RI 36, RI 58, AC 58

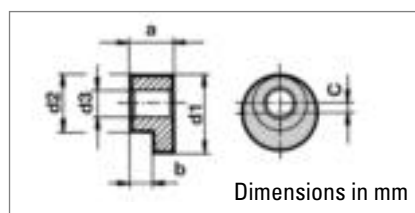

## SQUARE FLANGE ADAPTER 80 x 80 mm for clamping flange RI 58, AC 58 (fastening material included)

Ordering code 1 522 327

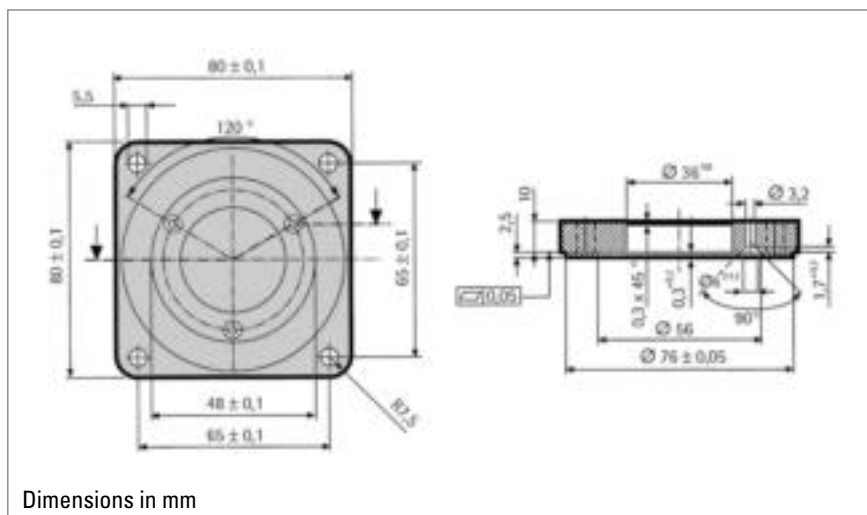

## SQUARE FLANGE ADAPTER 58 x 58 mm for clamping flange RI 58, AC 58 (fastening material included)

Ordering code 1 522 326

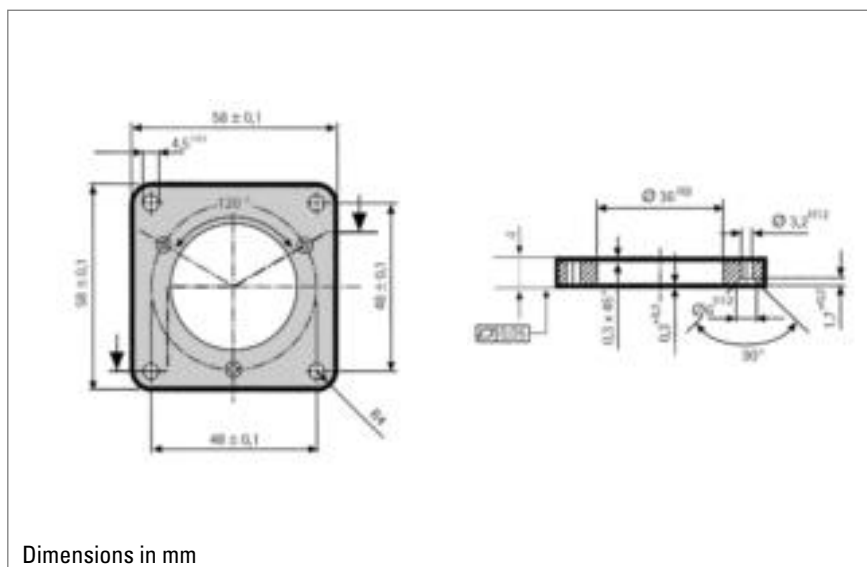

# Mounting

**SYNCHRO FLANGE ADAPTER**  
for clamping flange RI 58, AC 58  
(fastening material included)

Ordering code 1 522 328

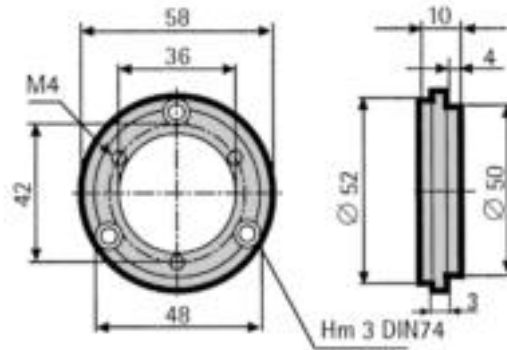

Dimensions in mm

**SYNCHRO FLANGE ADAPTER**  
for clamping flange RI 58,  
same dimensions as TR HE 65  
(fastening material included)

Ordering code 1 522 542

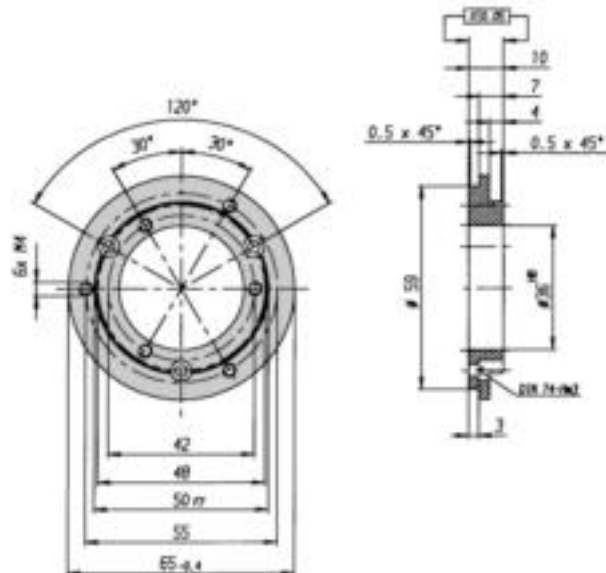

Dimensions in mm

**SYNCHRO FLANGE ADAPTER**  
for clamping flange RI 58,  
same dimensions as AG 661  
(fastening material included)

Ordering code 1 522 547

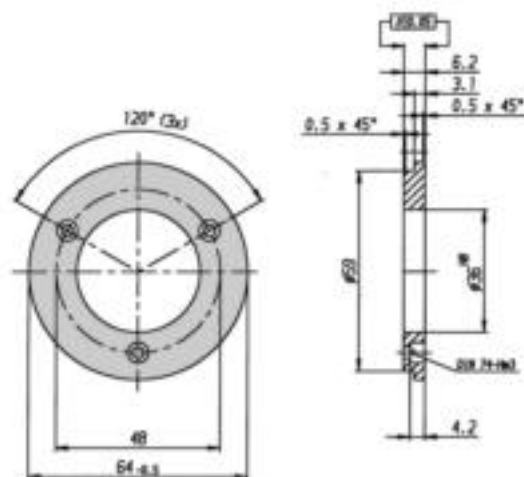

Dimensions in mm

## Mounting

**SYNCHRO FLANGE ADAPTER**  
for clamping flange RI 58,  
same dimensions as AG 100/110  
(fastening material included)

Ordering code 1 522 548

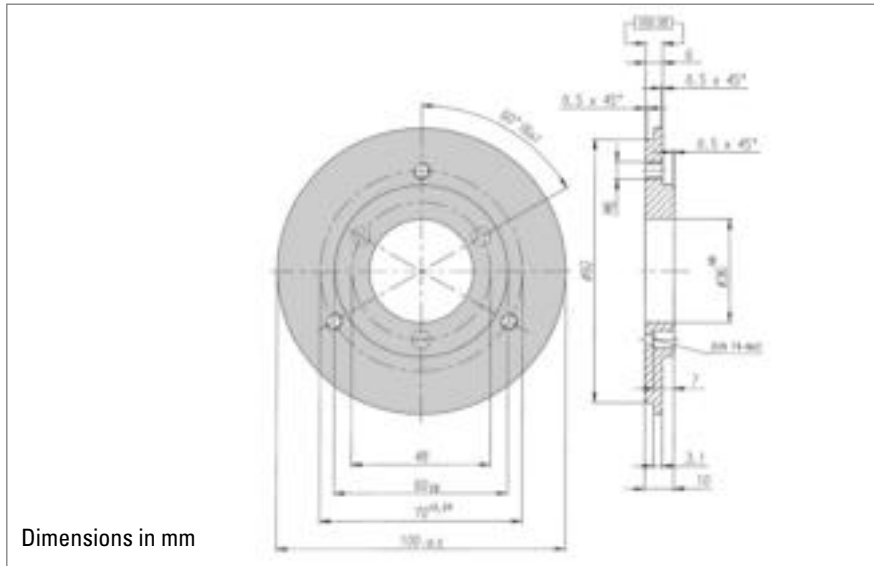

**FLANGE ADAPTER**  
for clamping flange AC 58,  
same dimensions as Gelma RAO 5  
(fastening material included)

Ordering code 1 540 336

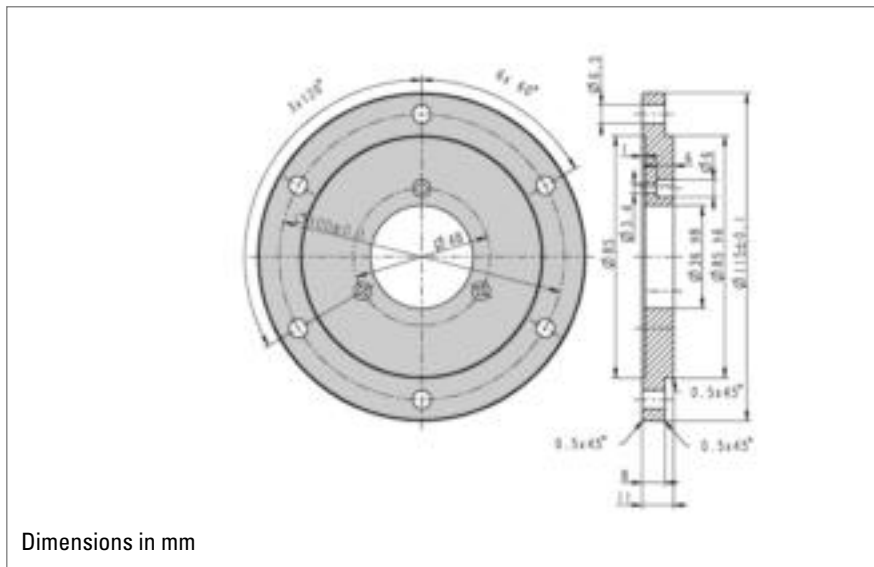

**FASTENING BRACKET (PLASTIC)**  
for clamping flange  
RI 58, AC 58  
(fastening material included)

Ordering code 1 522 329

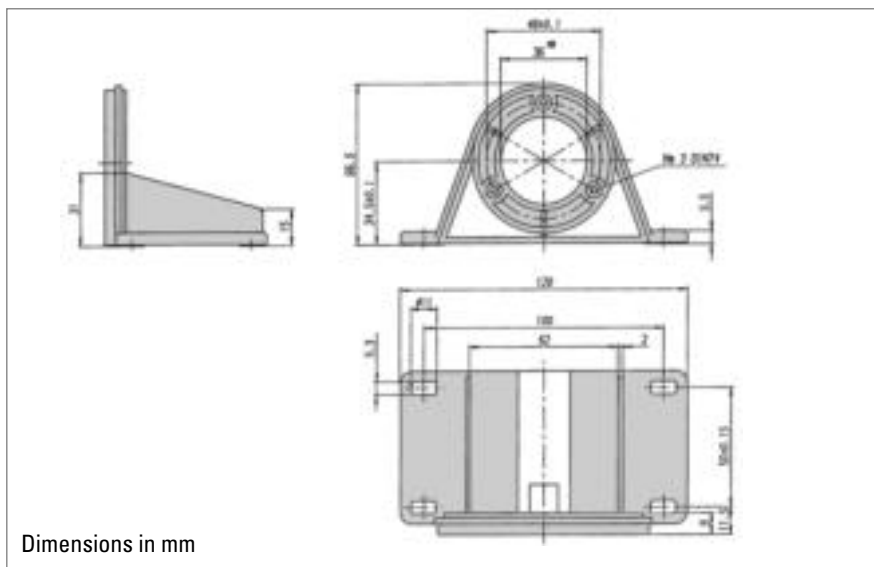

# Mounting

**MOUNTING BELL (PLASTIC)**  
for synchro flange RI 58, AC 58  
(clamping eccentric and  
fastening material included)

Ordering code 1 522 330

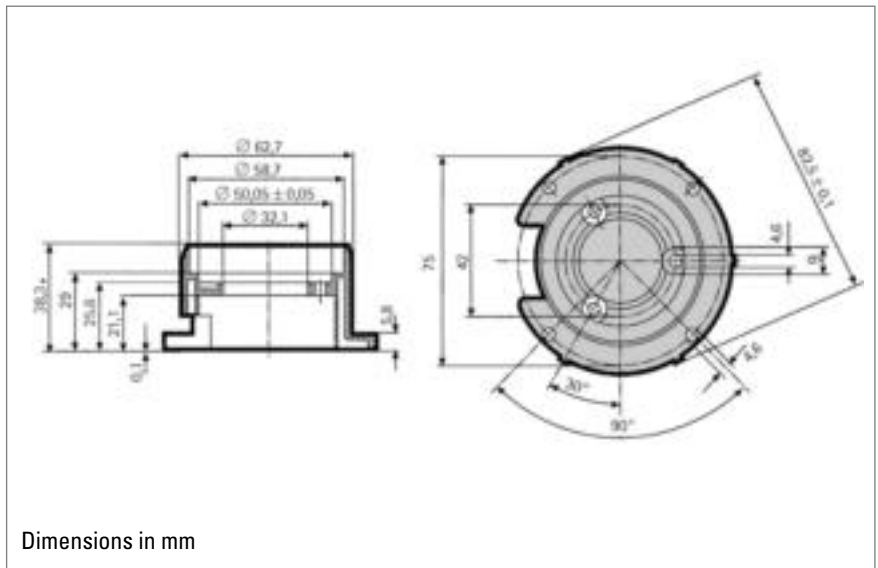

## FURTHER MOUNTING ACCESSORIES

	Ordering code
Hubshaft with tether as stator coupling, RI58-D	1 531 162
Hubshaft with tether BR.HA, RI76TD	1 533 119
Hubshaft with tether FE.GU, RI76TD	1 533 116
Hubshaft with tether flexible, RI76TD	1 533 079
Hubshaft with tether rigid, RI76TD	1 533 078
Torque support, RI58-F	2 531 199
Torque support, RI58-F, ACURO hollow shaft	1 531 188
Mounting kit (E9)	MK E9 + hollow shaft Ø
Mounting kit (M14)	MK M14 + hollow shaft Ø
Mounting kit (M9)	MK M9 + hollow shaft Ø

# Connectors

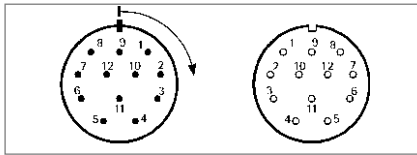

## NUMBERING OF PINS

### Clockwise system:

A connector with pin contacts, which is numbered clockwise, and the corresponding counter-plug connector with socket contacts (which consequently must be numbered counter-clockwise), is called right-turning.

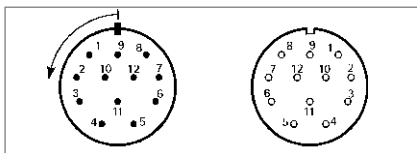

### Counter clockwise system:

A connector with pin contacts, which is numbered counter clockwise, and the corresponding counter-plug connector with socket contacts (which consequently must be numbered clockwise), is called left-turning.

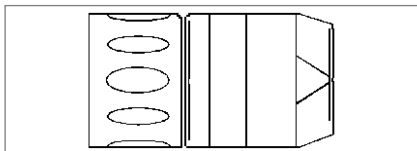

## PLUG

A connector with coupling nut is called plug, without regard to its pin or socket contacts.

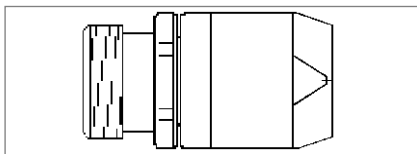

## COUPLING

A connector with outer thread is called coupling without regard to its pin or socket contacts.

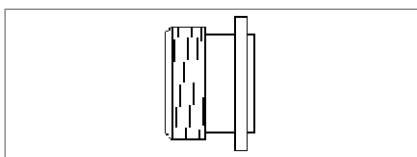

## CONNECTOR

A connector is fastened to the encoder or the machine's housing, has an outer thread (like the coupling) and is available with pin or socket contacts.

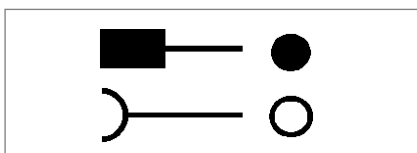

## CONTACTS

Sign for pin contact

Sign for socket contact



## Connectors

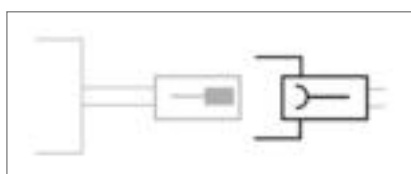
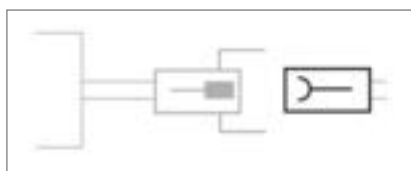
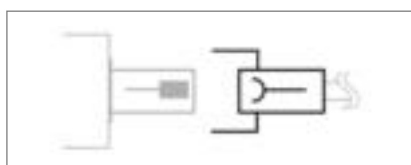

CONNECTOR (PINS) FOR MOUNTING IN ENCODER HOUSING	Ordering code
M23 (Conin), 12 pole, cw, mating connector for connection C/D (RI58, AC58)	3 539 198
M23 (Conin), 12 pole, ccw, identically equal to connection G/H (RI58, AC58)	3 539 230

CONNECTOR (SOCKET) MATCHING WITH ENCODER CONNECTOR <sup>1</sup>	Ordering code
M12, 8 pole, mating connector for connection 7/8 (AC58 BiSS/SSI)	3 539 597
M16 (Binder), 6 pole, bent, IP40, mating connector for connection J/N (RI30, RI36, RI58)	3 539 209
M16 (Binder), 6 pole, gerade, IP67, mating connector for connection J/N (RI30, RI36, RI58)	3 539 472
M23 (Conin), 12 pole, PG9, ccw, mating connector for connection G/H (RI58, AC58)	3 539 229
M23 (Conin), 12 pole, PG9, cw, mating connector for connection C/D/-I (RI58, AC58)	3 539 202
M23 (Conin), 17 pole, PG9, ccw, mating connector for connection U/V Singleturn (AC58 Parallel, ST)	3 539 256
M23 (Conin), 17 pole, PG9, cw, mating connector for connection W/Y Singleturn (AC58 Parallel, ST)	3 539 254
MS, 6 pole, mating connector for connection M/Q (RI58)	3 539 261
MS, 7 pole, mating connector for connection L/P (RI58)	3 539 262
MS, 10 pole, mating connector for connection K/O/R/T (RI58)	3 539 258
PT, 8 pole, mating connector for connection 1/2 (RI58)	3 539 333

<sup>1</sup> Extension cables with plug refer to "Connecting cables"

COUPLING (SOCKET) MATCHING WITH ENCODER CABLE WITH CONNECTOR	Ordering code
M23 (Conin), 12 pole, cw, mating connector for connection -C (cable plug 3 539 186) (RI30, RI36, RI58, RI76, RI80, AC58 Interbus)	3 539 187
M23 (VDW <sup>2</sup> ), 12 pole, cw, mating connector for connection -B (cable plug 3 539 252) (RI30, RI36, RI58, RI76, RI80)	3 539 304
SUB-D, 37 pole, mating connector for connection -F (cable plug 1 542 045) (AC 58 Parallel MT)	1 542 024

CONNECTOR (SOCKET) MATCHING WITH ENCODER CABLE WITH CONNECTOR	Ordering code
M23 (Conin), 12 pole, ccw, mating connector for connection G/H/-D/-H (RI30, RI36, RI58, RI76, RI80)	3 539 229
M23 (VDW <sup>2</sup> ), 12 pole, ccw, mating connector for connection -E (cable plug 3 539 274) (RI30, RI36, RI58, RI76, RI80)	3 539 305

<sup>2</sup> VDW corresponding to Conin plastic-coated

## Connectors

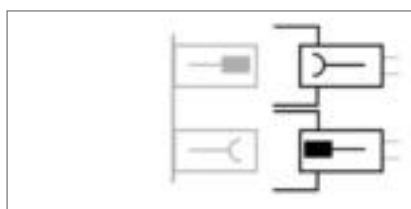
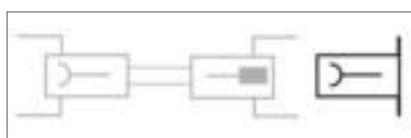
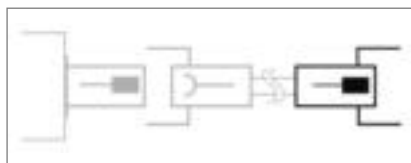

CONNECTOR (PINS) ON CONNECTING CABLE SUITABLE FOR DOWNSTREAM LOGIC CIRCUIT	Ordering code
M23 (Conin), 12 pole, PG9, ccw (RI30, RI36, RI58, RI76, RI80)	3 539 316
M23 (Conin), 12 pole, PG9, cw (RI30, RI36, RI58, RI76, RI80)	3 539 186
M23 (Conin), 17 pole, PG9, ccw (AC58 Parallel MT)	3 539 309
M23 (Conin), 17 pole, PG9, cw (AC58 Parallel MT)	3 539 317
M23 (VDW <sup>1</sup> ), 12 pole, PG9, cw (RI30, RI36, RI58, RI76, RI80)	3 539 252

COUPLING (PINS) ON CONNECTING CABLE SUITABLE FOR DOWNSTREAM LOGIC CIRCUIT	Ordering code
M23 (Conin), 12 pole, PG9, ccw (RI30, RI36, RI58, RI76, RI80)	3 539 273
M23 (Conin), 12 pole, PG9, cw (RI30, RI36, RI58, RI76, RI80)	3 539 301
M23 (Conin), 17 pole, PG9, ccw (AC58 Parallel MT)	3 539 303
M23 (Conin), 17 pole, PG9, cw (AC58 Parallel MT)	3 539 302
M23 (VDW <sup>1</sup> ), 12 pole, PG9, ccw (RI30, RI36, RI58, RI76, RI80)	3 539 274

<sup>1</sup> VDW corresponding to Conin plastic-coated

CONNECTOR (SOCKET) FOR MOUNTING INTO DOWNSTREAM LOGIC CIRCUIT HOUSING	Ordering code
M23 (Conin), 12 pole, ccw (RI30, RI36, RI58, RI76, RI80, AC58 BiSS/SSI, AC58 CANopen, AC58 CANlayer2, AC58 SSI-P)	3 539 319
M23 (Conin), 12 pole, cw (RI30, RI36, RI58, RI76, RI80, AC58 BiSS/SSI, AC58 CANopen, AC58 CANlayer2, AC58 SSI-P)	3 539 318

CONNECTOR FOR CONNECTING BUS COVER WITH 2X M23	Ordering code
M23 (Conin), 12 pole, PG9, cw, pins (AC 58 Profibus)	3 539 186
M23 (Conin), 12 pole, PG9, cw, socket (AC 58 Profibus)	3 539 202
M23 (Conin), 9 pole, PG9, cw, pins (AC58 CANopen, AC58 CANlayer2, AC58 Interbus)	3 539 293
M23 (Conin), 9 pole, PG9, cw, socket, (AC58 CANopen, AC58 CANlayer2, AC58 Interbus)	3 539 294

### Mounting accessories

	Ordering code
Mounting spanner for CONIN connectors	3 539 343

## Connecting Cables

### CONNECTING CABLES with plug (socket) on one end

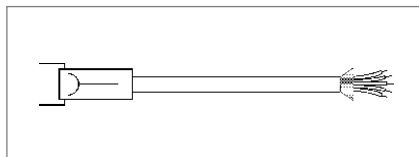

### M23 (CONIN), 12 POLE, FOR RI 30, RI 36, RI 58, RI 76, RI 80-E (TPE CABLE)

Pin	Colour <sup>1</sup>	Lead mm <sup>2</sup>
1	pink	0.14
2	blue	0.14
3	red	0.14
4	black	0.14
5	brown	0.14
6	green	0.14
7	violet	0.14
8	grey	0.14
9	Screen	0.14
10	white/green	0.5
11	white	0.14
12	brown/green	0.5
Housing	Screen	

<sup>1</sup> Cable version 3 280 112

### M16 (BINDER), 6 POLE FOR RI 30, RI 36, RI 58 (PVC CABLE)

Pin	Colour <sup>1</sup>	Lead mm <sup>2</sup>
1	red	0.5
2	white	0.14
3	yellow	0.14
4	green	0.14
5	yellow/black	0.14
6	black	0.5
Housing	Screen	

<sup>1</sup> Cable version 3 280 113

### M23 (CONIN), 12 POLE, FOR AC 58 WITH SSI-INTERFACE (TPE CABLE)

Pin	Colour <sup>1</sup>	Lead mm <sup>2</sup>
1	brown	0.5
2	pink	0.14
3	yellow	0.14
4		
5	blue	0.14
6		
7		
8	white	0.5
9		
10	grey	0.14
11	green	0.14
12	black	0.14
Housing	Screen	

<sup>1</sup> Cable version 3 280 220

### M12, 8 POLE FOR AC 58 BISS/SSI (PUR CABLE)

Length	Ordering code
3 m	<b>1 565 329</b>
5 m	<b>1 565 330</b>
10	<b>1 565 331</b>

Length	Matching with C/D/-I, cw <sup>1</sup>	Matching with G/H/-D/-H, ccw <sup>2</sup>
	Ordering code	Ordering code
3 m	<b>1 522 348</b>	<b>1 522 394</b>
5 m	<b>1 522 349</b>	<b>1 522 395</b>
10 m	<b>1 522 350</b>	<b>1 522 396</b>
15 m	<b>1 522 454</b>	<b>1 522 447</b>
20 m	<b>1 522 456</b>	<b>1 522 461</b>
25 m	<b>1 522 457</b>	<b>1 522 462</b>
30 m	<b>1 522 464</b>	<b>1 522 463</b>
40 m	<b>1 522 643</b>	<b>1 522 779</b>

<sup>1</sup> matching with encoder connector  
M23 (Conin), 12 pole, cw (C/D/-I)

<sup>2</sup> matching with encoder connector  
M23 (Conin), 12 pole, ccw (G/H/-D/-H)

Length	Ordering code
3 m	<b>1 522 405</b>
5 m	<b>1 522 404</b>
10 m	<b>1 522 340</b>
15 m	<b>1 522 833</b>
50 m	<b>1 522 836</b>

matching with encoder connector  
M16 (Binder), 6 pole (J, N)

Length	Matching with C/D, cw <sup>1</sup>	Matching with G/H, ccw <sup>2</sup>
	Ordering code	Ordering code
3 m	<b>1 542 003</b>	<b>1 542 010</b>
5 m	<b>1 542 004</b>	<b>1 542 011</b>
10 m	<b>1 542 005</b>	<b>1 542 012</b>
15 m	<b>1 542 006</b>	<b>1 542 013</b>
20 m	<b>1 542 007</b>	<b>1 542 014</b>
25 m	<b>1 542 008</b>	<b>1 542 015</b>
30 m	<b>1 542 009</b>	<b>1 542 016</b>
40 m	<b>1 542 026</b>	<b>1 542 028</b>
50 m	<b>1 542 027</b>	<b>1 542 029</b>

<sup>1</sup> matching with encoder connector  
M23 (Conin), 12 pole, cw (C/D)

<sup>2</sup> matching with encoder connector  
M23 (Conin), 12 pole, ccw (G/H)

matching with encoder connector  
M12, 8 pole (7/8)

## Connecting Cables

### CONNECTING CABLES with plug (socket) on one end

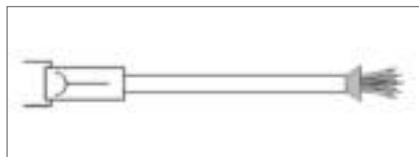

#### MS, 10 POLE FOR RI 58 (TPE CABLE)

Pin	Colour <sup>1</sup>	Lead mm <sup>2</sup>
A	brown	0.14
B	grey	0.14
C	red	0.14
D	brown/green	0.5
E	violet	0.14
F	white/green	0.5
G	green	0.14
H	pink	0.14
I	black	0.14
J	Screen	0.14

Length	Ordering code
3 m	<b>1 522 610</b>
5 m	<b>1 522 754</b>

matching with encoder connector  
MS, 10 pole (O/K)

<sup>1</sup> Cable version 3280112

#### M23 (CONIN), 12 POLE FOR AC 58 SSI-P (TPE CABLE)

Pin	Colour <sup>1</sup>	Lead mm <sup>2</sup>
1	green	0.14
2	yellow	0.14
3	pink	0.14
4	grey	0.14
5	brown	0.14
6	white	0.14
7	black	0.14
8	blue	0.14
9	red	0.14
10	violet	0.14
11	white	0.5
12	brown	0.5
Housing	Screen	

Length	Ordering code	ccw <sup>1</sup>
3 m	<b>1 543 002</b>	
5 m	<b>1 543 003</b>	
10 m	<b>1 543 004</b>	
15 m	<b>1 543 005</b>	
20 m	<b>1 543 006</b>	
25 m	<b>1 543 007</b>	
30 m	<b>1 543 008</b>	
40 m	<b>1 543 015</b>	
50 m	<b>1 543 016</b>	

<sup>1</sup> matching with encoder connector  
M23 (Conin), 12 pole, ccw (G/H)

<sup>1</sup> Cable version 3280220

#### SUB-D 37 POLE FOR AC 58 PARALLEL Multiturn (TPE CABLE)

Colour <sup>1</sup>	Pin	Colour <sup>1</sup>	Pin
brown	2	white/blue	14
green	21	brown/blue	33
yellow	3	white/red	15
grey	22	brown/red	34
pink	4	white/black	16
violet	23	brown/black	35
grey/pink	5	grey/green	17
red/blue	24	yellow/grey	36

Colour <sup>1</sup>	Pin	Colour <sup>1</sup>	Pin
white/green	6	pink/green	18
brown/green	25	yellow/pink	10
white/yellow	7	green/blue	30
yellow/brown	26	yellow/blue	12
white/grey	8	red	13
grey/brown	27	white	31
white/pink	9	blue	1
pink/brown	28	black	20

<sup>1</sup> Cable version 3280221

Length	Ordering code
1 m	<b>1 542 163</b>
3 m	<b>1 542 020</b>
5 m	<b>1 542 021</b>
10 m	<b>1 542 022</b>
15 m	<b>1 542 172</b>

Length	Ordering code
20 m	<b>1 542 173</b>
25 m	<b>1 542 174</b>
30 m	<b>1 542 175</b>
40 m	<b>1 542 176</b>
50 m	<b>1 542 177</b>

matching with encoder connector SUB-D, 37 pole (cable plug -F)

# Connecting Cables

## CONNECTING CABLES with plug (socket) on one end



### M23 (CONIN), 17 POLE FOR AC 58 PARALLEL Singleturn (PVC CABLE - 12 Bit pin assignment!)

Pin	Colour <sup>1</sup>	Lead mm <sup>2</sup>
1	brown/grey	0.14
2	red/blue	0.14
3	violet	0.14
4	white/brown	0.14
5	white/green	0.14
6	white/yellow	0.14
7	white/grey	0.14
8	white/pink	0.14
9	white/blue	0.14
10	white/red	0.14
11	white/black	0.14
12	brown/green	0.14
13	pink	0.14
14	green	0.14
15	black	0.5
16	red	0.5
17	brown	0.14
Housing	Screen	

<sup>1</sup> Cable version 3 280 100

Length	Matching with W/Y, cw <sup>1</sup>	Matching with U/V, ccw <sup>2</sup>
	Ordering code	Ordering code
3 m	<b>1 540 100</b>	<b>1 540 097</b>
5 m	<b>1 540 101</b>	<b>1 540 098</b>
10 m	<b>1 540 102</b>	<b>1 540 099</b>
15 m	<b>1 540 142</b>	<b>1 540 138</b>
20 m	<b>1 540 143</b>	<b>1 540 139</b>
25 m	<b>1 540 144</b>	<b>1 540 140</b>
30 m	<b>1 540 145</b>	<b>1 540 141</b>
40 m	<b>1 540 205</b>	<b>1 540 207</b>
50 m	<b>1 540 206</b>	<b>1 540 208</b>

<sup>1</sup> matching with encoder connector M23 (Conin), 17 pole, cw (W/Y)

<sup>2</sup> matching with encoder connector M23 (Conin), 17 pole, ccw (U/V)

Connection diagram see AC 58, parallel interface with connector.

### 12 POLE CONNECTING CABLE FOR AD 36

Ordering code		Ordering code	
0.3 m	<b>1 541 006</b>	2 m	<b>1 541 040</b>
0.5 m	<b>1 541 048</b>	3 m	<b>1 541 061</b>
1.5 m	<b>1 541 059</b>		

mating connector for connection 0/2

### 12 POLE CONNECTING CABLE FOR AD 58

Ordering code	
0.3 m	<b>1 547 078</b>
0.5 m	<b>1 547 049</b>

mating connector for connection 0

### RIBBON CABLE WITH CONNECTOR FOR E 9

Ordering code	
0.3 m	<b>CA 0 040 012</b>

### RIBBON CABLE WITH CONNECTOR FOR M 9

Ordering code	
0.3 m	<b>CA 0 050 012</b>

### RIBBON CABLE WITH CONNECTOR FOR M 14

Ordering code	
0.3 m	<b>CA 0 060 012</b>

### 14 POLE CONNECTING CABLE FOR S 21

Ordering code	
0.5 m	<b>1 548 003</b>



### M23 (CONIN), 12 POLE FOR RI 30, RI 36, RI 58, RI 76

Ordering code	
M23 (Conin), 12 pole, TPE cable, cw, mating connector for connection - C, 10 m (RI30, RI36, RI58, RI76)	<b>1 522 735</b>
M23 (Conin), 12 pole, TPE cable, cw, mating connector for connection - C, 20 m (RI30, RI36, RI58, RI76)	<b>1 522 621</b>

## Connecting Cables

### CONNECTING CABLES with connector on both ends



### CABLE NOT MADE UP WITH CONNECTORS

### M23 (CONIN), 12 POLE FOR AC58 INTERBUS (TPE CABLE)

Length <sup>1</sup>	Ordering code
3 m	<b>1 542 017</b>
5 m	<b>1 542 018</b>
10 m	<b>1 542 019</b>

<sup>1</sup> Cable version 3 280 220

	Ordering code
TPE cable for RI (12-core + screen)	<b>3 280 112 + length</b>
PVC cable for RI (10-core + screen)	<b>3 280 114 + length</b>
PVC cable for RI (6-core + screen)	<b>3 280 113 + length</b>
PVC cable for AC58 Parallel ST (20-core + screen)	<b>3 280 100 + length</b>
TPE cable for AC58 SSI, AC58 Interbus (12-core + screen)	<b>3 280 220 + length</b>
TPE cable for AC58 Parallel MT (32-core + screen)	<b>3 280 221 + length</b>

# Measuring Wheels

## GENERAL ASPECTS



In order to prevent the result being distorted when the shaft encoder is driven by a measuring wheel make sure that the slip is as small as possible. When selecting the tread (surface), take into account the structure, stretchability, thickness, and resistance to being carried along of the material being measured.

The slip is also affected by the width of the measuring wheel, the contact pressure, the tension in the material being measured, and the arc of contact. The arc of contact should be as large as possible. The wheel bodies are made of cast aluminium or plastic (as marked).

The position of the measuring wheel should be chosen so that the direction of movement of the material is away from the shaft encoder's bearing point.

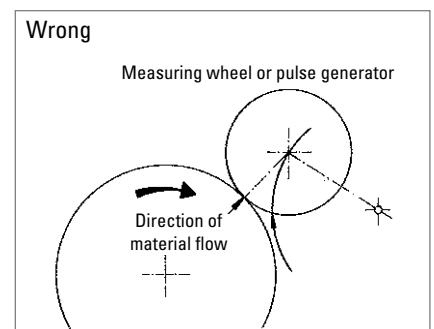
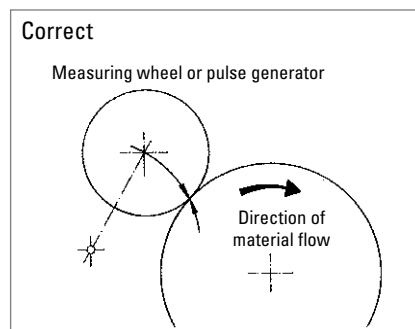

## MEASURING WHEEL TREADS

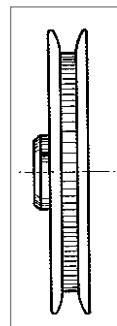

**Tread 1**  
with rim and  
fine crosshatched knurl  
Material: aluminium

Applications such as  
threads and yarns

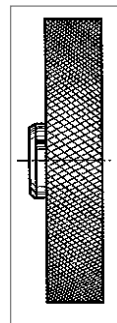

**Tread 2**  
with glued-on rubber profile  
A = soft specially clinging rubber  
surface (red)  
B = low-wear rubber surface with  
good grip (white)

Applications such as  
paper and cardboard, measuring  
cables, nongreasy metals, fleece,  
undressed or surface-treated  
wood, soft and hard plastics.

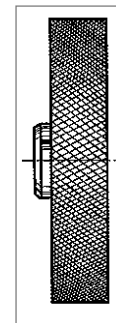

**Tread 3**  
vulcanized rubber  
surface with parallel  
knurl

Applications such as  
rubber, leather, fabrics,  
flooring and glass.

# Measuring Wheels

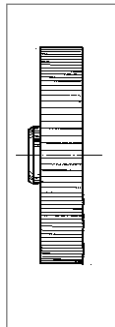

### Tread 4

aluminium with parallel knurl

Applications such as rubber, soft plastics, wood with rough surface, and to a limited extent for fabrics.

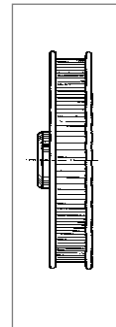

### Tread 5

with rim, aluminium with parallel knurl

Applications such as threads, yarns, and bands.

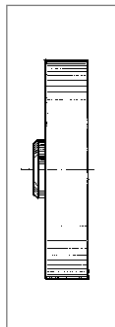

### Tread 6

plastic surface

Applications such as wire, greasy metals, and steel sections.

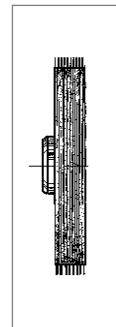

### Tread 7

carding belt

Applications such as carpets and coarse fabrics.

## ORDERING DATA Aluminium

Dia- meter	Circum- ference	Tread	Width of bearing surface	Bore diameter (mm) fitting to encoder shaft				
				4.0 mm	6.0 mm	7.0 mm	10.0 mm	12.0 mm
6.37 cm	0.2 m	1	4 mm	0 601 014	0 601 015	0 601 017		
		2 A	12 mm	0 601 018				
		2 B	12 mm	0 601 118	0 601 048		0 601 049	
		2 A	24 mm	0 601 020		0 601 092		
		2 B	24 mm			0 601 192		
		4	20.5 mm	0 601 023				
		4	20 mm			0 601 093		
		5	16.5 mm	0 601 026		0 601 094		
		15.92 cm	0.5 m	2 A	25 mm			0 601 050
2 B	25 mm					0 601 150	0 601 151	
2 B	25 mm					0 601 204		
3	25 mm					0 601 059	0 601 156	0 601 159
4	25 mm					0 601 121 <sup>1</sup>	0 601 157	
6	25 mm					0 601 063 <sup>1</sup>	0 601 163	0 601 165
5.73 cm	1/5 yd.	1	4 mm	0 601 034		0 601 037		
		2 A	24 mm	0 601 042				
		5	16.5 mm			0 601 096		
14.33 cm	1/2 yd.	4	25 mm			0 601 061		
9.70 cm	1 foot	2 A	25 mm			0 601 071		
		2 B	25 mm			0 601 171		

## Plastic

6.37 cm	0.2 m	1	4 mm			0 601 100		
		4	25 mm			0 601 301		
15.92 cm	0.5 m	6	25 mm			0 601 300		

<sup>1</sup> PTB approved

Other measuring wheels available on request



## Displays, Software, Technical Manuals

### DISPLAYS

	Ordering code
"Tico" display for connection T, AC58 Profibus, AC58 DeviceNet	0 731 205
"Tico" display for connection T (Caution: Neutralizes ohmic isolation) AC58 CANopen, AC58 CANLayer2	0 731 205
Connection cable bus cover (connection T) to "tico", 1.5 m, AC58 Profibus, AC58 CANopen, AC58 CANLayer2, AC58 DeviceNet	3 539 516
Position indicator Signo-SS, AC58 BiSS/SSI, AC58 SSI-P	0 727 111

### SOFTWARE

	Ordering code
EDS-file, as download from our homepage, AC58 CANopen, AC58 DeviceNet, AC61 CANopen, AC61 DeviceNet, AX70/71 CANopen	www.hengstler.com
EDS-file, as download from our homepage, AC58 Profibus, AC61 Profibus, AX70/71 Profibus	www.hengstler.com
Software Win SSI, as download from our homepage, AC 58 SSI-P, AC 61 SSI-P	www.hengstler.com
Software Win SSI, AX70/71 SSI-P	on request
Win SSI PC connecting cable, for M23 (Conin), 12 pole, ccw (suited for supply voltage E and connection G or H), AC58 SSI-P	1 543 010

### TECHNICAL MANUALS

	Ordering code
Technical manual, German, AC58 Profibus, AC61 Profibus, AX70/71 Profibus	2 565 090 (or homepage)
Technical manual, English, AC58 Profibus, AC61 Profibus, AX70/71 Profibus	2 565 255 (or homepage)
Technical manual, German, AC58 CANopen, AC61 CANopen, AX70/71 CANopen	2 565 250 (or homepage)
Technical manual, English, AC58 CANopen, AC61 CANopen, AX70/71 CANopen	2 565 329 (or homepage)
Technical manual, German, AC59/61 DeviceNet	2 565 094 (or homepage)
Technical manual, English, AC59/61 DeviceNet	2 565 256 (or homepage)
Technical manual, German, AC58 Interbus, AC59/61 Interbus	2 565 217 (or homepage)
Technical manual, German, AC58 SUCOnet	2 547 080 (or homepage)
Technical manual, English, AC58 SUCOnet	2 547 081 (or homepage)
Technical manual, German, AC58 SSI-P, AC61 SSI-P, AX70/71 SSI-P	2 565 287 (or homepage)
Technical manual, English, AC58 SSI-P, AC61 SSI-P, AX70/71 SSI-P	2 565 289 (or homepage)

# Encoder Basics

## GENERAL INFORMATION

Incremental encoders are sensors capable of generating signals in response to **rotary movement**. In conjunction with mechanical conversion devices, such as rack-and-pinions, measuring wheels or spindles, incremental shaft encoders can also be used to measure **linear movement**. The shaft encoder generates a signal for each incremental change in position.

With the **optical transformation**, a line-coded disc made of metal, plastic or glass and positioned on a rotary bearing interrupts the infra red light ray emitted by gallium arsenid sender diode. The number of lines determines the resolution, i.e. the measuring points within a revolution. The interruptions of the light ray are sensed by the receptor element and electronically processed. The information is then made available as a rectangular signal at the encoder output.

## Output Signals of Incremental Encoders

## OUTPUT SIGNALS

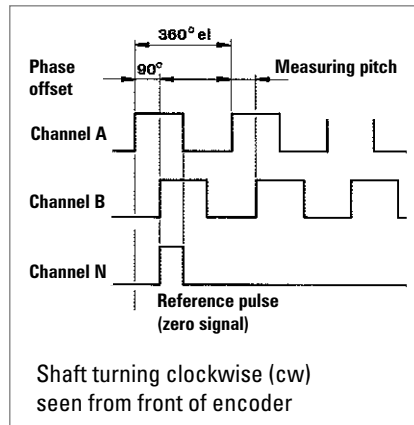

The shaft encoders supply two square wave pulses offset by  $90^\circ$  A and B, and a reference pulse N (zero signal) as well.

In order to suppress spurious pulses, certain output circuits (RS 422 and push-pull) generate inverted signals ( $\bar{A}$ ,  $\bar{B}$ ,  $\bar{N}$ ), such as in models RI 30, RI 36, RI 58, RI 58-H, RI 76-TD and RI 58-D.

The measuring pitch is defined as the value of the distance between two pulse edges of A and B.

## EVALUATION

The resolution of a two-channel shaft encoder can be doubled or quadrupled in the subsequent circuitry.

This enables the resolution of a two-channel encoder with 2500 lines per rev. to be increased electronically to 5,000 or 10,000 pulses per revolution (see diagram below).

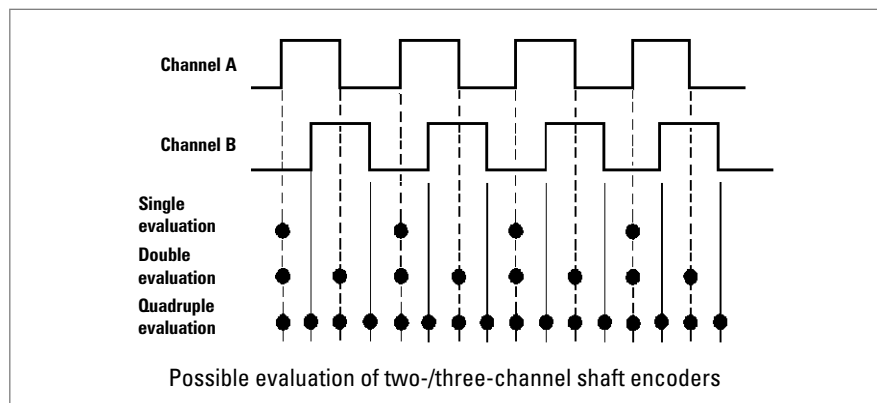

# Encoder Basics

## Maximum Speed, Protection Class

### SPEED

The maximum permissible speed of a shaft encoder is derived from:

- the **mechanically permissible r.p.m.**,
- the minimum permissible **pulse-edge spacing** of the square-wave output signals of the shaft encoder for the subsequent circuitry, which depends on the tolerance of the phase offset,
- the **functional speed**, which is limited by the pulse frequency.

The mechanically permissible r.p.m. is specified for each shaft encoder among the mechanical characteristics.

In general, the control circuitry does not permit less than a certain **minimum edge spacing** between the square-wave output signal pulses. The minimum pulse-edge spacing is specified for each model of shaft encoder among the electrical characteristics.

The **functional speed** of an encoder is obtained by the equation:

$$n_{\max} = f_{\max} \cdot 10^3 \cdot 60 / Z$$

$n_{\max}$  = maximum functional speed [r.p.m.]

$f_{\max}$  = maximum pulse frequency of shaft encoder, or input frequency of downstream circuitry [kHz]

$Z$  = number of pulses of shaft encoder

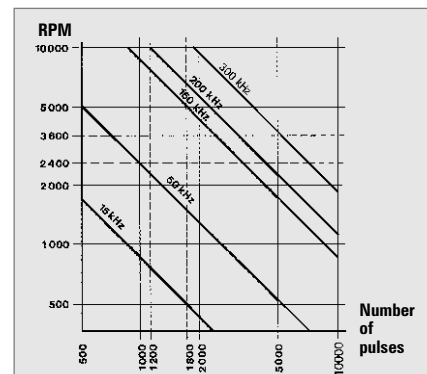

Maximum permissible speed as a function of number of pulses and signal frequency of shaft encoder

### PROTECTION CLASS

All encoders of the industrial types RI 30, RI 36, RI 58, RI 58-H, RI 58-D, RA 70-I as well as the absolute encoders ACURO, comply with protection class IP65 according to EN 60529 and IEC 529, unless otherwise stated.

These specifications are valid for the housing and the cable output and also for plugged in socket connectors. The shaft input complies with protection class IP64. If however the encoder is mounted vertically, there must be no standing water present at the shaft input and the ball bearings.

In case the standard protection class IP64 is not sufficient for the shaft input, e.g. with vertical mounting of the encoder, the encoders must be protected by additional labyrinth or pot-type seals.

On request our encoders are also available with protection class IP67 for the shaft input and for the housing.

# Encoder Basics

## Examples of Flange Mounting

### FLANGE TYPE OVERVIEW

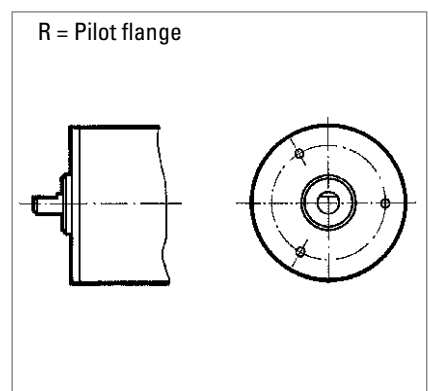
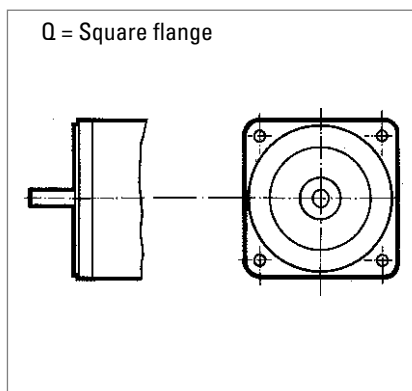
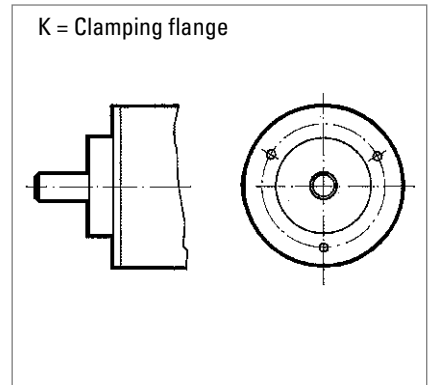
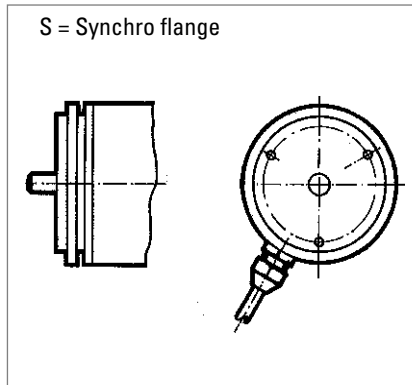

### SHAFT ENCODERS WITH CLAMPING FLANGE

The shaft encoders with a clamping flange can be installed in following ways:

- by means of various flange adapters (see "Accessories"),
- by means of the clamping flange itself,
- by means of the fastening threads provided on the face,
- by means of an angle bracket (see "Accessories").

The encoder housing is centered by means of the clamping flange.

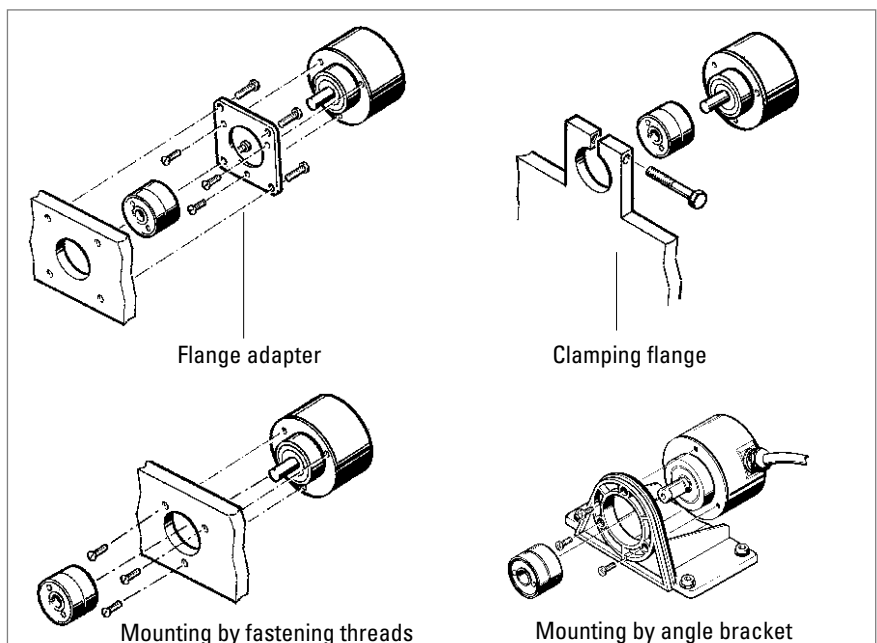

## Encoder Basics

### Examples of Flange Mounting

#### SHAFT ENCODERS WITH SYNCHRO FLANGE

The shaft encoders with synchro flange can be installed in two ways:

- by means of the synchro flange and three clamping eccentrics (see "Accessories"),
- by means of the fastening threads provided on the face.

The encoder is centered by means of the centering collar on the flange.

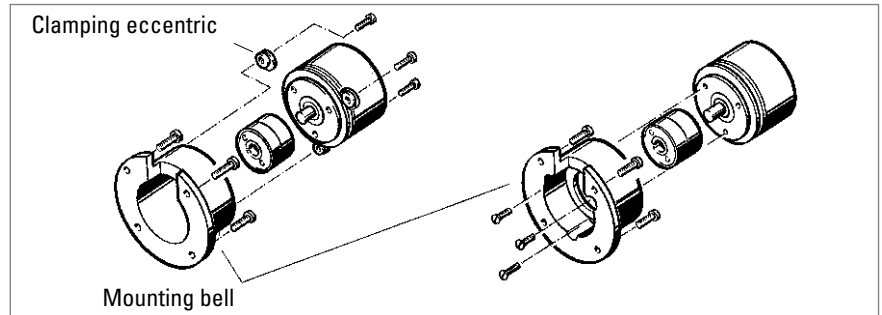

#### SHAFT ENCODERS WITH SQUARE FLANGE

The shaft encoders with square flange can be installed in two ways:

- by means of the fastening threads provided on the face,
- by means of an angle bracket.

The encoder is centered by means of the centering collar on the flange.

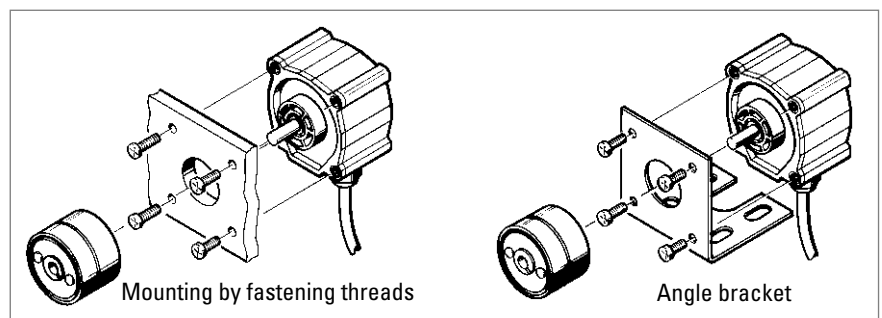

#### SHAFT ENCODERS WITH PILOT FLANGE

The shaft encoders with pilot flange can be installed in two ways:

- by means of the fastening threads provided on the face,
- by means of an angle bracket.

The encoder is centered by means of the centering collar on the flange.

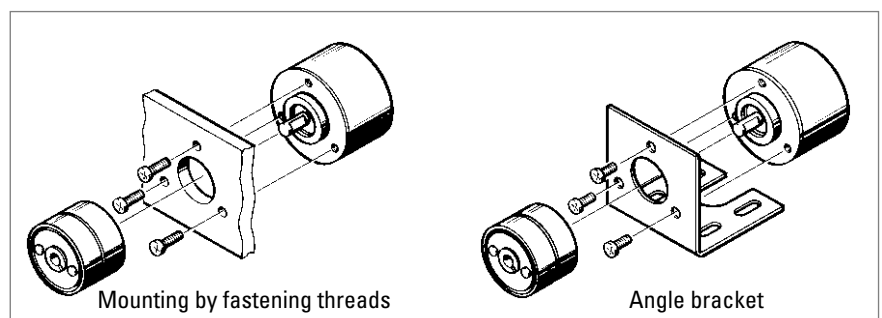

## Encoder Basics

### Examples of Flange Mounting

#### SHAFT ENCODERS WITH HOLLOW SHAFT (RI 58-D/G)

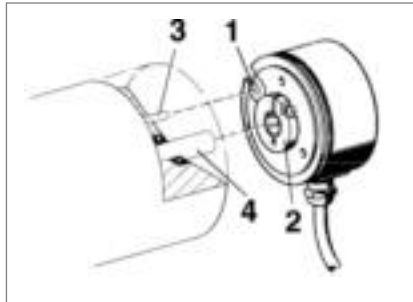

Mounting of version F, D (Clamping shaft)

- 1 Torque support
- 2 Clamping ring with cross-recess screw
- 3 Straight pin
- 4 Actuating shaft

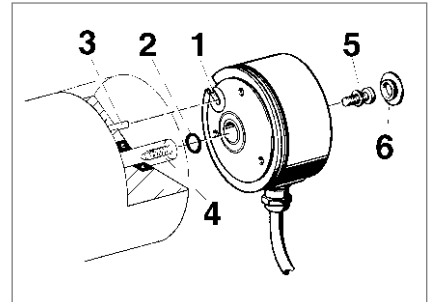

Mounting of version E (Blind shaft)

- 1 Torque support
- 2 O-ring
- 3 Straight pin
- 4 Actuating shaft with threaded bore
- 5 M4-screw with spring washer
- 6 Cap

#### SHAFT ENCODERS WITH HOLLOW SHAFT (RI 76, RI 80-E, AC110)

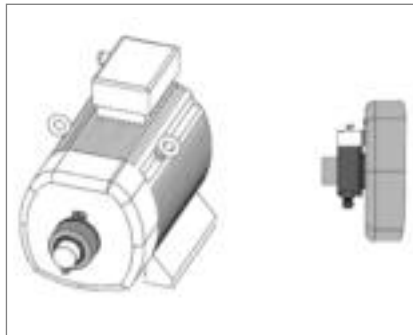

#### MOTOR SHAFT ENCODERS WITH HOLLOW SHAFT (E9, M9)

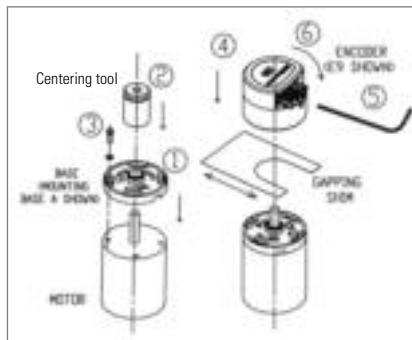

1. Place the base plate of encoder onto the motor rear end plate.
2. Install centering tool on motor shaft to center the base plate with respect to the shaft.
3. Install hardware supplied and tighten to secure the base plate. Remove centering tool.
4. Position and mount the encoder housing onto the base plate with its 3x120' bayonet snaps in their corresponding slots on the base plate. Slide the gapping shim between the base plate and the encoder from the side opposite the connector.
5. Place the hex wrench into the codewheel set screw. Tighten the set screw while pushing the codewheel down toward the gapping shim with the wrench.
6. Remove the gapping shim, push down and twist the encoder 30° clockwise to lock it in place.

#### SHAFT ENCODERS WITH SOLID SHAFT

Connection of solid-shaft encoders to the shaft is by means of a coupling. The coupling compensates for axial movements and lack of alignment between the shaft encoder and the drive shaft, thus preventing excessive bearing loads on the encoder shaft. For further details please refer to chapter "Accessories".

# Basics of Incremental Encoders

## Outputs - RS 422 - TTL

### OUTPUT CIRCUIT

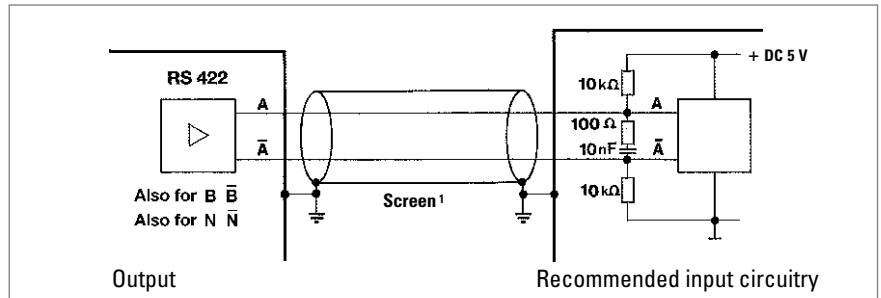

<sup>1</sup> Cable screen:

- not existing for RI 32, 38, 42,
- connected to encoder housing for RI 30, 36, 58, 59, 76 and RA 70

### TECHNICAL DATA

Code letter	R = RS 422 + Alarm <sup>3</sup> (with $U_B = DC 5/10 - 30 V$ ) T = RS 422 + Sense <sup>4</sup> (only with $U_B = DC 5 V$ )
Output signals shaft turning clockwise (cw) seen from front of encoder	<p>Square wave pulses (TTL) for channels A, B, N and their inverted signals <math>\bar{A}</math>, <math>\bar{B}</math>, <math>\bar{N}</math></p>
Delay times at 1,5 m cable	<p><math>\leq 100 ns \leq 100 ns</math></p>
Pulse shape	
Pulse duty factor	1:1
Phasing	$90^\circ \pm 25^\circ$ electrical
Symmetry	$180^\circ \pm 25^\circ$ electrical
Max. Output frequency	300 kHz
Output voltage	DC 0 ... +5 V <sup>2</sup>
Output level	$H \geq DC 2,5 V / L \leq DC 0,5 V$ (TTL-level)
Output load max.	$\pm 30 mA$
Short circuit protection	with $U_B = DC 5 V$ : only 1 channel at a time for max. 1 s (Standard RS 422-driver) with $U_B = DC 10 - 30 V$ : short circuit proof for all channels due to integrated controller
Pole protection of $U_B$	with $U_B = DC 5 V$ : no      with bei $U_B = DC 10 - 30 V$ : yes

<sup>1</sup> Distance A to B is at least 0,45  $\mu s$  (at 300 kHz)

<sup>2</sup> also for  $U_B = DC 10 - 30 V$

<sup>3</sup> Description - see Outputs Alarm

<sup>4</sup> Description - see Outputs Sense

### CABLE LENGTH

depending on voltage and frequency (at 25 °C) <sup>1</sup>:

Length	RS 422
10 m	DC 5 V, 300 kHz
50 m	DC 5 V, 300 kHz
100 m	DC 5 V, 300 kHz

<sup>1</sup> with Hengstler accessory cables

# Basics of Incremental Encoders

## Outputs - Push-pull

### OUTPUT CIRCUIT

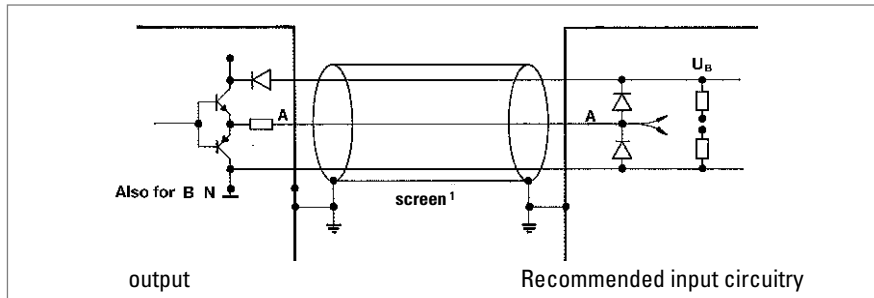

<sup>1</sup> Cable screen:

- not existing for RI 32, 38, 42
- Not connected to encoder housing for bei RI 41
- Connected to encoder housing for RI 30, 36, 58, 59, 76 and RA 70

### TECHNICAL DATA

Code letter	K = push-pull, 10 mA with $U_B = DC 5 V$ or push-pull, 30 mA with $U_B = DC 10 - 30 V$ D = push-pull, 30 mA with $U_B = DC 5 V$		
Output signals shaft turning clockwise (cw) seen from front of encoder			
Delay times at 1,5 m cable	<ul style="list-style-type: none"> <li>■ <math>\leq 100 \text{ ns}</math> (DC 5 V, push-pull D)</li> <li>■ <math>\leq 250 \text{ ns}</math> (DC 5 V, push-pull K)</li> <li>■ <math>\leq 2 \mu\text{s}</math> (DC 10 - 30 V, push-pull K)</li> </ul>		
Pulse shape			
Pulse duty factor	1:1		
Phasing	$90^\circ \pm 25^\circ$ electrical		
Symmetry	$180^\circ \pm 25^\circ$ electrical		
Max. Output frequency	300 kHz (see cable length)		
Output voltage	$0 \dots + U_B$		
Output level	K	K	D
	push-pull (DC 10 - 30 V)	push-pull (DC 5 V)	push-pull (DC 5 V)
	$H \geq U_B - 3V$	$H \geq 2,5 V$	$H \geq 2,5 V$
	$L \leq 2 V$	$L \leq 0,5 V$	$L \leq 0,5 V$
Output load max.	$\pm 30 \text{ mA}$	$\pm 10 \text{ mA}$	$\pm 30 \text{ mA}$
Short circuit protection	all channels	all channels	1 channel <sup>2</sup>
Pole protection of $U_B$	yes	yes	no

<sup>1</sup> Distance A to B is at least  $0,45 \mu\text{s}$  (at 300 kHz)

<sup>2</sup> only 1 channel at a time for max. 1 s

### CABLE LENGTH

depending on voltage and frequency (at 25 °C) <sup>1</sup> :			
Length	push-pull (K) DC 5 V, 10 mA	push-pull (D) DC 5 V, 30 mA	push-pull (K) DC 10 - 30 V, 30 mA
10 m	300 kHz	300 kHz	DC 12 V, 200 kHz DC 24 V, 200 kHz DC 30 V, 200 kHz
50 m		300 kHz	DC 12 V, 200 kHz DC 24 V, 200 kHz DC 30 V, 100 kHz
100 m		300 kHz	DC 12 V, 200 kHz DC 24 V, 100 kHz DC 30 V, 50 kHz

<sup>1</sup> with Hengstler accessory cables



# Basics of Incremental Encoders

## Outputs - Push-pull complementary

### OUTPUT CIRCUIT

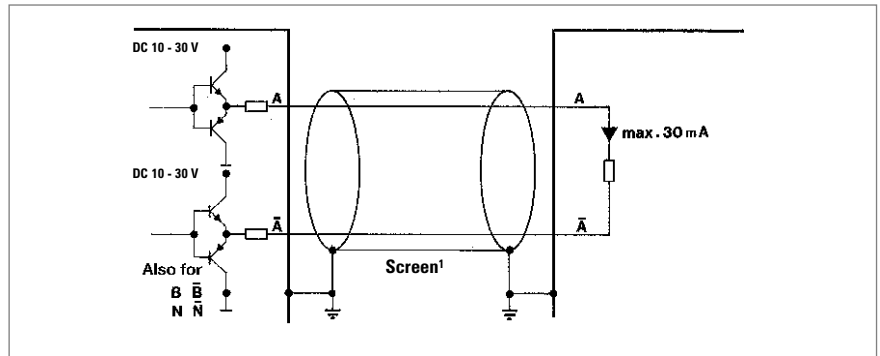

<sup>1</sup> cable screen connected with encoder housing

### TECHNICAL DATA

Code letter	I = push-pull complementary (with $U_B = DC 10 - 30 V$ )
Output signals shaft turning clockwise (cw) seen from front of encoder	
Delay times at 1,5 m cable	 $\leq 250 \text{ ns}$
Pulse shape	
Pulse duty factor	1:1
Phasing	$90^\circ \pm 25^\circ$ electrical
Symmetry	$180^\circ \pm 25^\circ$ electrical
Nax. output frequency	200 kHz (see cable length)
Output voltage	$0 \dots + U_B$
Output level	$H \geq U_B - 3V / L \leq 2V$
Output load max.	$\pm 30 \text{ mA}$
Short circuit protection	short circuit proof for all channels due to integrated controller
Pole protection of $U_B$	yes

<sup>1</sup> Distance from A to B is at least  $0,7 \mu s$  (at 200 kHz)

### CABLE LENGTH

depending on voltage and frequency (at $25^\circ C$ ) <sup>1</sup> :	
Length	push-pull complementary
10 m	DC 12 V, 200 kHz
	DC 24 V, 200 kHz
	DC 30 V, 200 kHz
50 m	DC 12 V, 200 kHz
	DC 24 V, 50 kHz
	DC 30 V, 25 kHz
100 m	DC 12 V, 150 kHz
	DC 24 V, 25 kHz
	DC 30 V, 12 kHz

<sup>1</sup> with Hengstler accessory cables

# Basics of Incremental Encoders

## Outputs - Alarm

### OUTPUT CIRCUIT

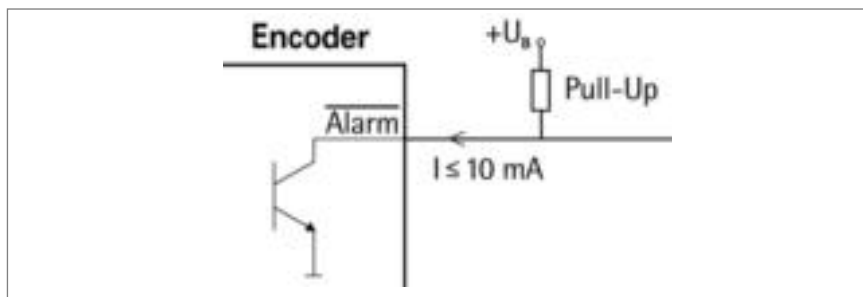

### TECHNICAL DATA

Output	NPN - Open collector
Output load max.	5 mA / 24 V at $U_B = DC\ 5\ V$ 5mA / 32 V at $U_B = DC\ 10-30\ V$
Output level	Output active (failure condition): $L \leq DC\ 0,7\ V$ Output inactive: high impedance (if necessary: get H-level by an external pull-up resistor)
Malfunction indication time	$\geq 20\ ms$

### FUNCTION

The rotary encoders are equipped with an electronic monitoring system that reports potential malfunctions via a separate alarm output.

The alarm output can be used for selecting an optical display (LED; for circuit, see above) or the control system (SPC or similar).

Moreover, the alarm outputs of several encoders can be interconnected to a common "systems alarm" by means of a parallel connection. The following errors are indicated:

Category I	Category II	Category III
- damaged disks	- overtemperature	- voltage range $DC\ 1\ V < U < DC\ 4\ V$
- defective LED	- overload (e. g. due to short circuit)	- voltage drop on the supply lines
- contamination		

Category I malfunctions cannot be corrected; the encoder must be replaced.

Category II malfunctions are detected by means of a thermal monitoring unit in the electronic system. The alarm message is cleared after the cause of temperature increase has been removed.

Category III malfunctions indicate insufficient supply voltage. Also included in this category are transients in the supply voltage, e.g. due to electrostatic discharge, which may distort the output signals.

This is corrected by

- readjustment to the correct voltage
- eliminating the cause of disturbance, i.e. by careful arrangement of the cables.

## Basics of Incremental Encoders

### Outputs - Sense at 5 V RS 422 (T)

#### OUTPUT CIRCUIT

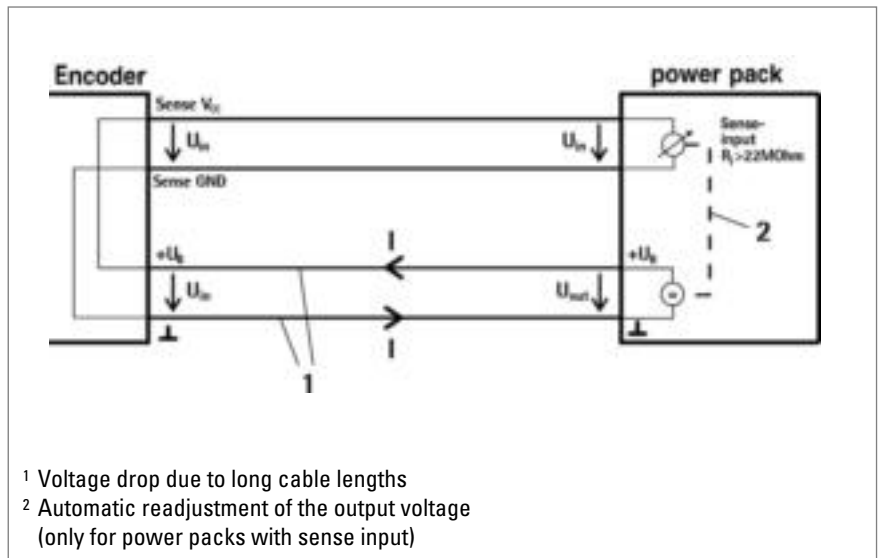

#### FUNCTION

The sense wires enable measuring of the actual encoder supply voltage (compensates for voltage drops due to supply current and cable resistance).

Due to the voltage drop in the cables and the voltage supply, the encoder input voltage  $U_{in}$  is less than the power pack output voltage  $U_{out}$ .

The present input voltage  $U_{in}$  is now output to the Sense  $V_{CC}$  and Sense GND cables and returns as data to the power pack.

The input resistance  $R_i$  on the power pack should amount to at least 22 M $\Omega$  so that no voltage drop occurs on these cables.

In case of power packs with sense input, it is now possible to readjust the output voltage  $U_{out}$  automatically.

## Basics of Sine-Wave Encoders

### GENERAL INFORMATION

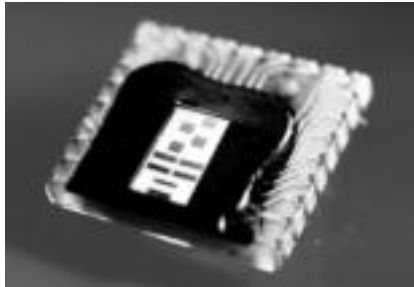

### SINE-WAVE OPTOASIC TECHNOLOGY BURSTS THE LIMITS

With the introduction of the sine-wave encoder family, Hengstler has taken the opportunity to significantly rework its OptoAsic technology.

The best features have been maintained and new improvements have been introduced. One major feature that has been retained of course, is the high level of EMC reliability which we have achieved by integrating almost the complete encoder electronics into one component.

What is new is the integrated offset and amplitude control together with the in-chip optical system adjustment. In the past anybody wanting high quality, accurate sine-wave signals at low frequencies had to trade in this for bandwidth. We are now able to meet this apparently contradictory requirement with our in-built amplitude control. You can't fail to be convinced by a unit which delivers sine-wave signal with harmonic distortion better than 1% at low speed and 500 kHz max. frequency.

**The advantages are crystal clear:** If you need precision at slow speeds you no longer have to compromise your productivity because the encoder limits the maximum speed of your machine e.g. for tool changing processes. You can have both - accuracy and speed.

### APPLICATIONS

#### Typical applications:

- Machine tools
- Printing machines
- Gearless elevators
- Drives

# Basics of Sine-Wave Encoders

## Signals

### THE RIS58 SIGNALS

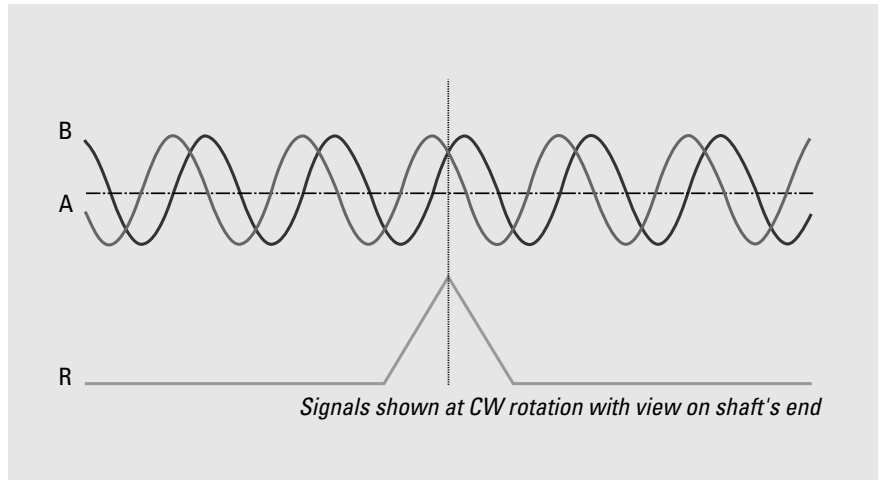

The incremental signals A and B and the zero signal R are differential voltage signals. The differential signal level is 1 V<sub>pp</sub>. The zero signal appears once per revolution with a peak of 0.4 V and reaches its maximum value at the angle where the amplitudes of the A and B signals are equal. All signals have a DC-offset of 2.5 V.

### THE RIS58 SIGNAL QUALITY

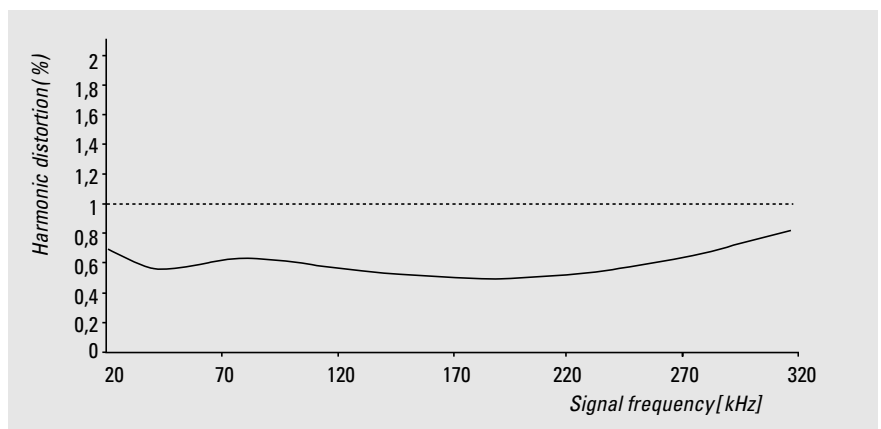

The quality of the servo loop is determined to a large extent by the absence of harmonics in the encoder's sinewave signals, particularly at low speed. In order to achieve high interpolation factors in the sequencing control, the incremental sine signals A and B are available with a harmonic distortion significantly under 1% throughout the specified temperature range. This delivers excellent synchronism and a high level of positional accuracy with servo axes.

## Basics of Absolute Encoders ACURO

### ABSOLUTE ENCODERS FOLLOW THE LATEST TREND: CHANGE EASILY TO ACURO

Absolute encoders save costs and provide enhanced safety - facts that are obviously important in complex installations and multi-axis machinery: Time-consuming reference runs after powering-up the supply voltage have become a thing of the past for absolute encoders. Hazardous conditions caused by reference runs (which are always necessary with incremental encoders) can be prevented right from the start. Absolute encoders - too large, too expensive?

A prejudice that is cleared up by ACURO. Even the multi turn version of ACURO is no larger than most incremental encoders and costs less than you would expect. And how about reliability? Due to their complexity, absolute encoders seem to be susceptible to faults. No problem with ACURO: once installed they will not cause trouble, due to the highest integration density and use of extremely reliable technologies to ensure safe and reliable long-term operation.

### The platform concept

Hengstler's new ACURO absolute encoders feature innovative technology, simple operational and optimal functional safety. Their platform concept also allows especially compact dimensions with a modular design, which always ensures the right version for each individual application in the field of motor feedback and automation engineering. Equipped with the new open BiSS interface these encoders are a good and future oriented investment.

The mechanical construction of ACURO is rugged and precise. Double high-precision ball bearings guarantee reliable long-term operation even at speeds of up to 12000 rpm. ACURO is equipped with the commercially available mechanical interfaces, including solid shaft or hub shaft, synchro-flange or clamping flange.

### ABSOLUTE ENCODERS ARE DIFFERENTIATED ACCORDING TO:

#### Singleturn version

1 revolution (= 360 °) is coded in n steps. After a rotation of over 360 ° the code is repeated.

#### Multiturn version

Apart from measuring 360 ° (1 revolution) further coded revolutions can be recorded e.g for applications in combination with lead screws or timing belts. Hengstler is using the principle of a mechanical memory (gearbox, which is unmatched in reliability and EMC).

## Basics of Absolute Encoders ACURO

### High-Tech Features in a Modular System

#### INNOVATIVE TECHNOLOGY

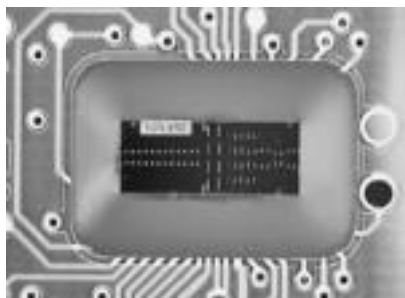

Hengstler's ACURO series comprises a complete range of absolute encoders, all in OPTOASIC technology. OPTOASIC units combine all required optical and electronic components in only one silicon chip.

This new technology is tailored to the user's needs and offers advantages previously unknown in the field:

- **High degree of reliability** due to differential scanning and single-step Gray code.
- **Fail-safe** due to the elimination of more than a hundred components
- **Long serviceable lifetime** due to state-of-the-art semiconductor technology-

- High degree of **electromagnetic compatibility** due to elimination of macroscopic low-current paths.

Our new absolute shaft encoders have an excellent price/performance ratio. As a further feature the encoders are fully backward compatible due to identical mounting flanges and electrical interfaces.

This makes it easy for the user to switch from incremental to absolute shaft encoders.

#### PROGRAMMABLE ABSOLUTE SHAFT ENCODERS

All essential parameters are user-programmable.

Additional advantages are uncomplicated subsequent data processing, electronic adjustment and add-on optimization of mechanical systems which are subject to tolerances.

Furthermore, storage and maintenance are more cost-efficient: the same encoder may be used for a variety of applications and assigned to its task at the place of installation.

#### APPLICATIONS

The new encoders are, for example, perfectly suited to determine angular positions in automated systems with reliable and precise operation.

Absolute encoding eliminates the need for a reference run after interruptions (such as power failures).

ACURO is the right match for a wide range of applications - from medical technology, elevators, all printing, paper processing or metal-processing machinery, such as presses and saws, right through to highly-dynamic drives.

#### INTERFACES



Of course, the user has a selection of the most advanced interface technology available:

- Tristate parallel drivers  
The symmetrical push-pull drivers are fully short circuit proof, overload protected and polarity protected in a range from 10 to 30 V.  
Parallel bus systems are easy to realize. So you save in cabling expenses.
- CAN  
Bus specifications according to CAN High-Speed ISO/DIS 11898 for transfer rates up to 1 MBaud.
- Suconet K1  
Klöckner-Moeller 2 wire fieldbus
- DeviceNet
  - Based on CAN layer 2 (data link layer)
  - Up to 64 nodes and 500 KBAud speed
  - Configuration via network

- INTERBUS  
Interface including the potential-free power supply is already integrated in the housing with a diameter of only 58 mm.

- SSI  
The encoders can also be supplied with synchronous-serial interface (SSI) which is available worldwide.  
This allows trouble-free connection to commercial processing components.

- Profibus DP  
Protocol according to encoder profile class C2 (programmable)

- BiSS
  - bidirectional and fully digital
  - synchronous serial data
  - licence-free
  - up to 8 slaves per master

# Basics of Absolute Encoders ACURO

## Open Digitale Sensor Interface (BiSS)

### GENERAL INFORMATION

The bidirectional digital sensor interface BiSS safeguards communication between position encoders or measuring devices and industrial controls, such as a drive control, for example, and if necessary can transmit measurement values from up to 8 sensors simultaneously.

**For 1 to 8 subscribers** the interface master provides a clock signal for the simultaneous capture of all position data and for the synchronous-serial data transmission which

follows on from this. Just four unidirectional RS422 data lines are required; the slave electronics, kept to an absolute minimum, are incorporated on the sensor ICs.

When the master sends a clock pulse on line MA, the slave answers directly on return line SL with the recorded position data. Commands and parameters can be swapped on a PWM pulse form; this is, however, not necessary to start the BiSS protocol.

### TRANSFER SEQUENCE

**With each data cycle** the master learns and compensates for line delays, thus permitting clock rates of up to 10 Mbit/s even for cable lengths of up to 100 m. Changes in line conditions which occur during cable drag, for example, are corrected. The precision of synchronization among several position encoders along various axes is less than 1 microsecond; the master also makes the signal delay it has recorded accessible to the control unit, allowing further optimization.

**The BiSS protocol** classifies each subscriber in the following data sections: sensor data, register data. These data sections have various setups with regard to access and transmission performance so that a number of different sensor applications are

catered for. Bidirectional parameter communication for device configuration - also applicable to what are known as OEM parameters - is usually consigned to the register data section, with rapidly changing angle data being assigned to the sensor data section.

**Control cycle times of less than 100  $\mu$ s** are thus not a problem, even for data words of up to 64 bits in length. There is enough room in the protocol for redundancy; this space is normally used to implement a CRC (cyclic redundancy check). Framed by just one start and one stop bit, the sensor data is transmitted at the best-possible core data rate. Permanent monitoring of the position and operation of the encoder is possible without interfering with the control cycle.

### Block diagram of a BiSS Master-Slave configuration

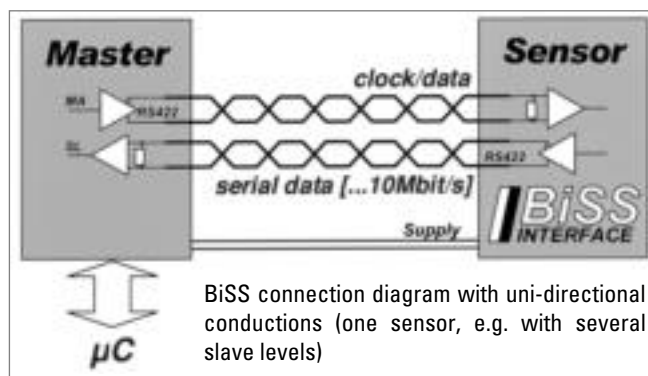

### Configuration

**Specific product developments** of individual users are not restricted or made unnecessarily expensive by a compulsory compatibility.

A BiSS subscriber is described with just a few parameters and the XML-descriptive file included with the delivery simplifies start up of the control system.

**i** For further information see: [www.biss-interface.com](http://www.biss-interface.com)



# Basics of Absolute Encoders ACURO

## Synchronous-Serial Interface (SSI)

### GENERAL INFORMATION

In many cases, absolute shaft encoders are subject to severe mechanical stresses and to electrical and magnetic fields that contaminate the site.

Therefore, special design measures are needed to combat dirt, dust and liquids in industrial environments.

Our absolute shaft encoders are of state-of-the-art rugged mechanical construction, and the electronic components are very compact.

A main consideration for immunity to interference is the data transfer from the shaft encoder to the control system. The control system must be able to read the readings from the shaft encoder without errors. Under no circumstances should undefined data be transmitted, for example at the changeover point.

The major differences between the concept of synchronous-serial data transfer for absolute shaft encoders described here and parallel and asynchronous serial forms of data transfer are:

- less electronic components
- less cabling for data transfer
- the same interface hardware, regardless of the absolute shaft encoder's resolution (word length)
- electrical insulation of the shaft encoder from the control system by optocouplers
- open-circuit monitoring by constant current
- data transfer rates up to 1.5 megabits per second (depending on the length of line)
- ring-register operating possible.

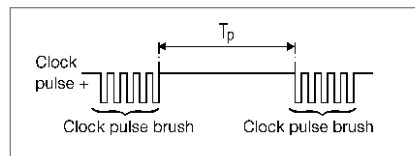

### TRANSFER SEQUENCE

For correct transfer of the data a defined number of pulses (clock pulse brush) must be applied to the clock input of the absolute shaft encoder. Next, a pause  $T_p$  must be observed. As long as no clock signal is applied to the shaft encoder, its internal parallel/serial shift register remains switched to parallel. The data change continuously, corresponding to the current position of the shaft encoder's shaft.

As soon as a clock pulse brush is applied to the clock input again, the instantaneous angular data is recorded.

The first shift of the clock signal from high to low ① actuates the shaft encoder's internal retriggerable mono-stable element, whose storage time  $t_m$  must be greater than the clock signal's period  $T$ .

The output of the monostable element controls the parallel/serial register via terminal P/S (parallel/serial).

### Block diagram of an absolute shaft encoder

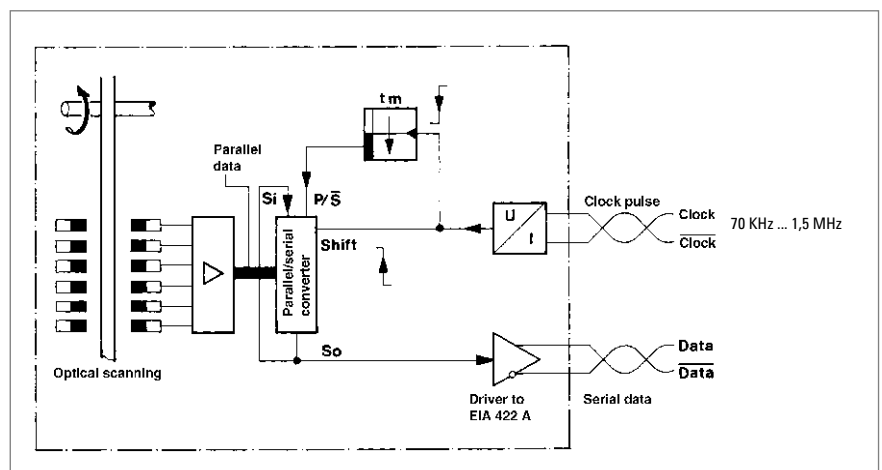

# Basics of Absolute Encoders ACURO

## Synchronous-Serial Interface (SSI)

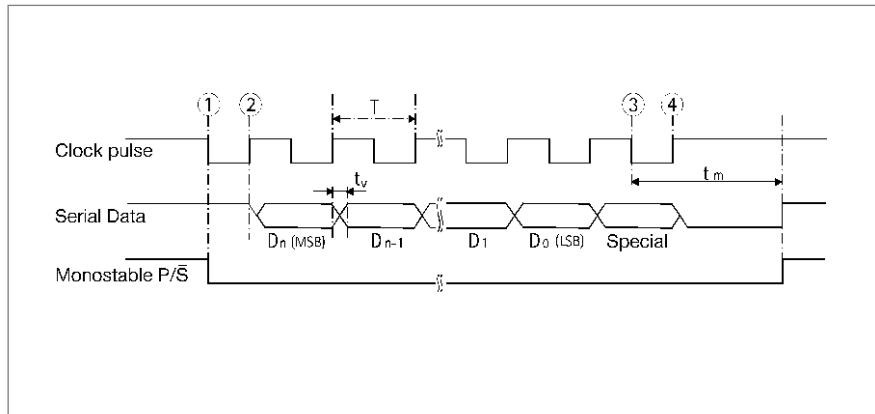

$T$  = clock pulse period

$t_m$  = storage time of monostable element

$t_m$  ranging from 10  $\mu$ s to 30  $\mu$ s

$t_v$  = 100 ns

The number of clock pulses necessary for data transfer is independent of the resolution of the absolute shaft encoder.

The clock signal can be interrupted at any point, or continued in ring-register mode for repeated polling.

With the first shift of the clock signal from low to high ② the most significant bit (MSB) of the angular data is applied to the shaft encoder's serial output.

With each succeeding rising edge, the next less significant bit is shifted to the data output.

After transmission of the least significant bit (LSB) the Alarm bit or other special bits are transferred, depending on configuration. Then the data line switches to low ③ until the time  $t_m$  has passed.

A further transfer of data cannot be started until the data line switches to high ④ again. If the clock pulse sequence is not interrupted at point ③, the ring-register mode is activated automatically. This means that the data stored at the first clock pulse transition ① are returned to the serial input  $S_i$  via the terminal  $S_0$ . As long as the clock pulse is not interrupted at ③, the data can be read out as often as wanted (multiple transfer).

# Basics of Absolute Encoders ACURO

## Synchronous-Serial Interface (SSI)

Input circuit

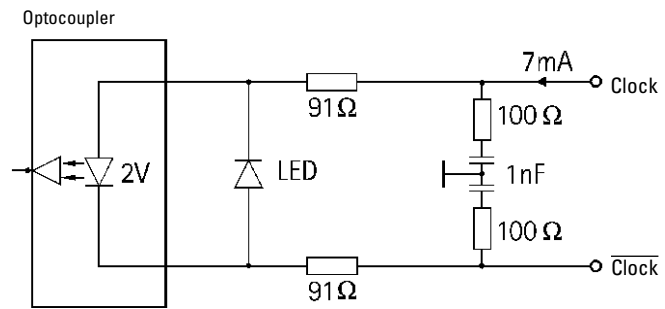

Output circuit

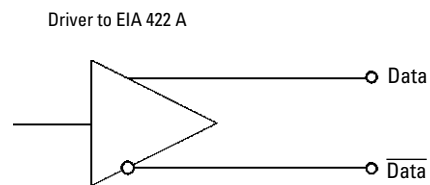

### RECOMMENDED DATA TRANSMISSION RATE

The maximum data transmission rate depends on the length of cable:

Cable length	Baud rate
< 50 m	< 400 kHz
< 100 m	< 300 kHz
< 200 m	< 200 kHz
< 400 m	< 100 kHz

# Basics of Absolute Encoders ACURO

## INTERBUS

### GENERAL INFORMATION

INTERBUS is a real-time bus for the sensor-actor-level which is able to transfer data with a small overhead in a range of up to 4 bytes per subscriber for a maximum of 256 subscribers.

It is characterized by a circular transmission with a fixed message frame and a central master (e.g. SPC switching-in assembly).

### TRANSFER SEQUENCE

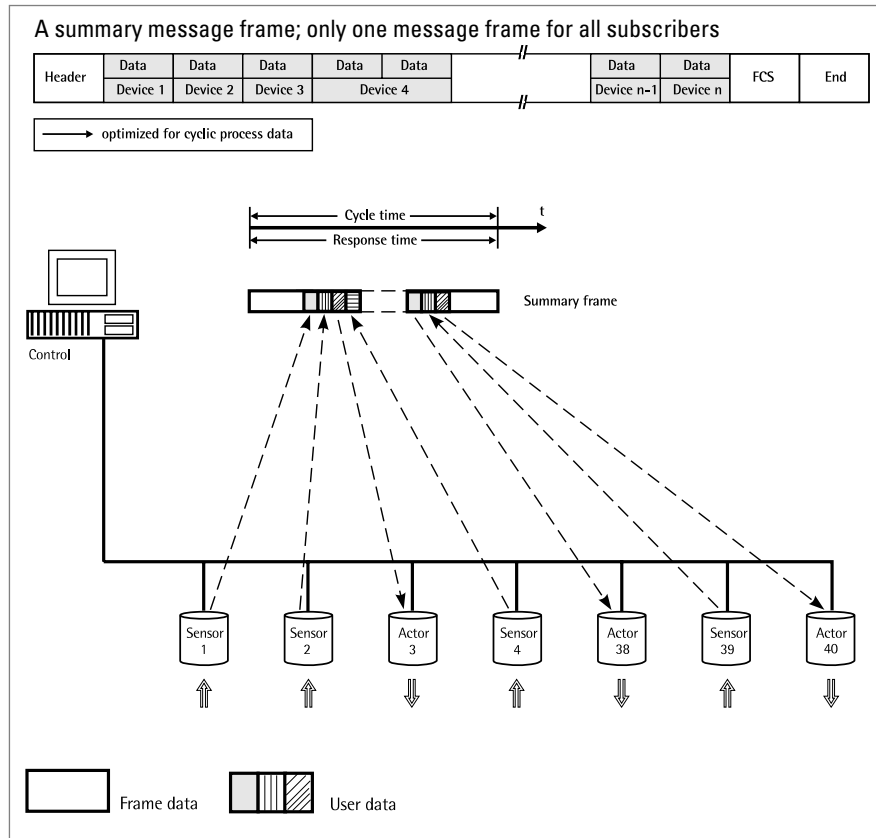

### WHAT ARE THE BENEFITS OF INTERBUS COMPARED WITH A CONVENTIONAL SYSTEM WIRING?

- Lower costs for cables and wiring
- Lower noise sensitivity
- Many control signals which were analog before are now available as digital signals and directly transferable by INTERBUS
- Simple layout, installation and starting procedure
- High efficiency (net data rate): the percental share of the message header and of the terminating sequence decreases with a growing number of subscribers
- Data of all subscribers are stored at the same time and transferred sub-sequently
- Reaction time can easily be determined. It only depends on the system's total extension; this is important for controlling tasks
- Constant sampling rate for reference inputs and actual values; both are transferred in one bus cycle
- Considerations of priority are unnecessary since all subscribers have the same priority

## INTERBUS

- No system-parameter definition before starting procedure
- Data integrity is secured by 16-bit-CRC (according to CCITT polynomial) done for each transmission
- Sophisticated diagnostic software for the central bus controller: a point of error can specifically be isolated; in each case of malfunction there is a possibility to close the circular system in every single bus clip.

Devices with an INTERBUS interface for process control are now available from more than 200 manufacturers.

Encoder manufacturers are joined together in the ENCOM user group; drive manufacturers in DRIVECOM.

The user groups shall maximize the benefit for the customer by standardization of data transmission.

There is a high availability of devices with INTERBUS interface, and the bus mode has already been successful in industrial use.

### ENCOM USER GROUP



The following device classes defined by ENCOM are used for absolute shaft encoders:

#### Class 2 (K2):

- 32-bit process data
- Binary
- Right-justified
- Readable only
- No control bits or status bits

#### Class 3 (K3):

- 32-bit process data
- Coded according to manufacturer specifications
- Right-justified
- 7 status bits and control bits

# Basics of Absolute Encoders ACURO

## INTERBUS

### TECHNICAL DATA

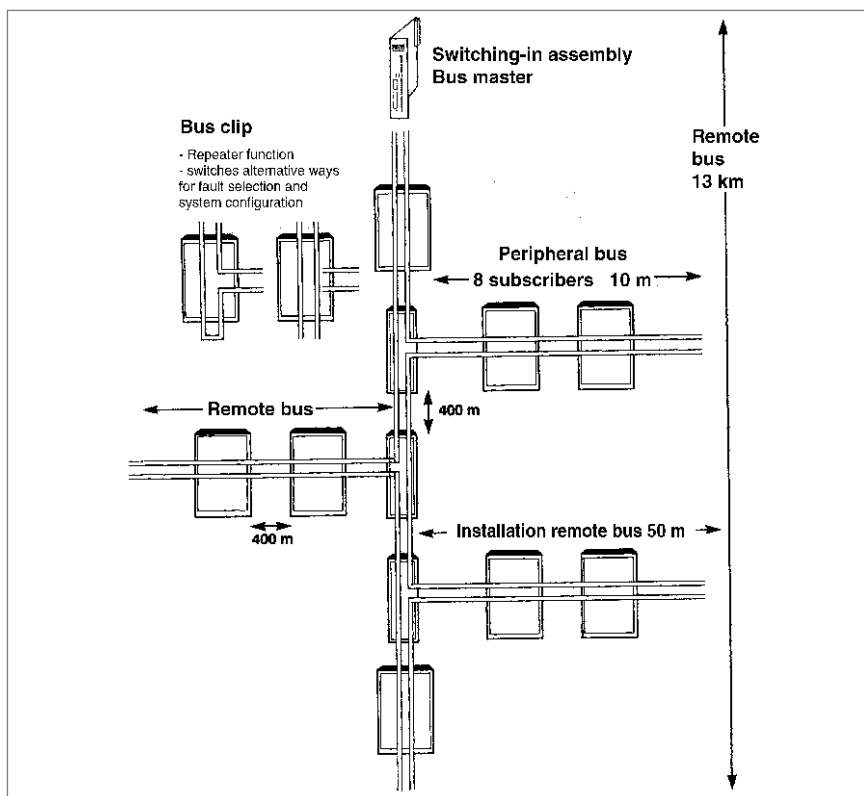

INTERBUS is physically divided into:

#### Remote bus

- Voltage difference transmission RS 485
- Max. cable length between two bus clips: 400 m
- Max. overall cable length of remote bus: 13 km
- A maximum of 64 bus clips/modules may be directly connected to the remote bus

#### Peripheral bus

- 5 V voltage interface
- Max. overall cable length of peripheral bus: 10 m
- A maximum of 8 modules may be connected

#### Installation remote bus

- For modules with enclosure class IP65 (e.g. HENGSTLER absolute shaft encoders)
- Voltage difference transmission RS 485
- Max. overall cable length: 50 m
- Connection via bus clip or passive T-manifold
- Each subscriber has an electrically isolated voltage transformer
- 24 V supply may be led via the bus line or be connected to the T-manifold
- 8 modules may be connected.

The transmission speed is **500 kBit/s**.

## INTERBUS

### INTERBUS DIAGNOSTIC CONCEPT

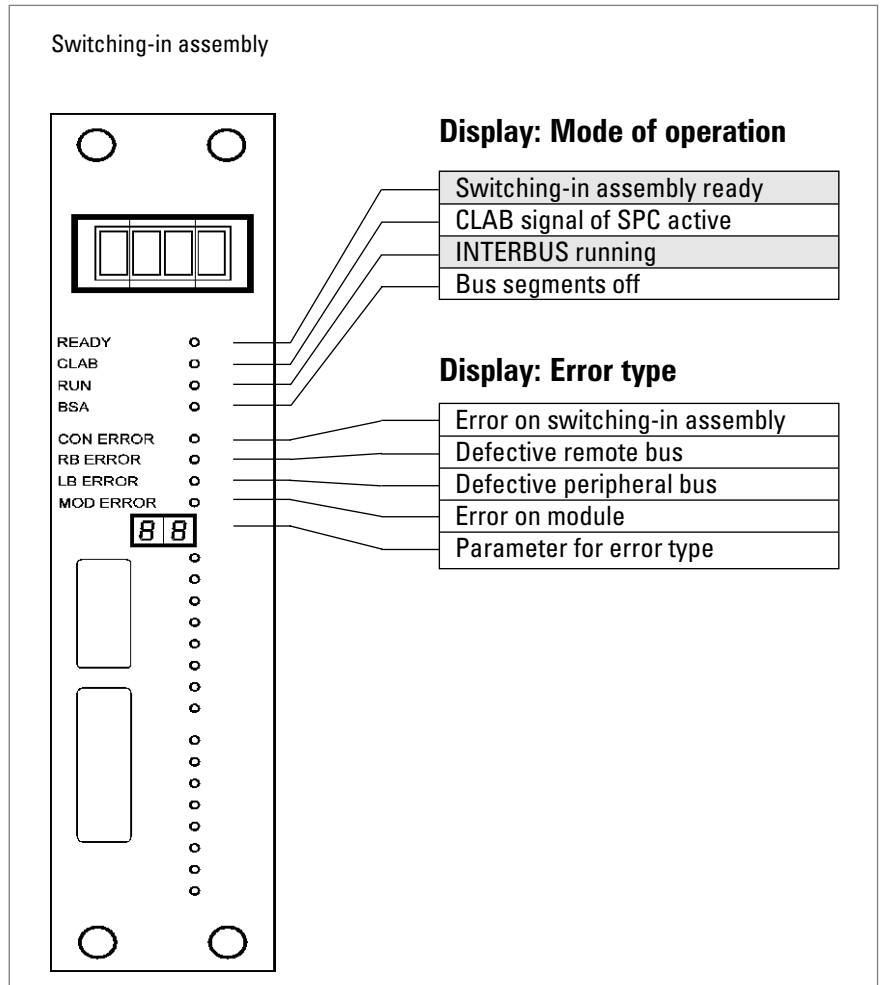

The diagnostic system is able to indicate peripheral and controller errors beside the selection of faults. Due to a row of LEDs comprising 16 bits, available on most switching-in assemblies, decentralized process states can be displayed centrally.

- Status display on control system for inputs and outputs without hand programming unit

- Self-acting fault detection and display with point and type of error without user programming

- Usual diagnosis by hand programming unit can be kept

- Diagnostic representation is always the same regardless of the control system.

**i** For further information see:  
[www.interbusclub.com/de](http://www.interbusclub.com/de)

## CANopen

### GENERAL INFORMATION

The AC 58 is an absolute shaft encoder (encoder, angle encoder). The version described in this technical manual sends its current position to another station via the "CAN-bus" transmission medium (physically: screened and twisted two-wire line).

The serial bus system CAN (Controller Area Network), which had been originally developed by Bosch/ Intel for automotive uses, is gaining ground in industrial automation technology. The system is multimaster-compatible, i.e. several CAN- stations are able to request the bus at the same time. The message with the highest priority (determined by the identifier) will be received immediately.

The data transfer is regulated by the message's priority. Within the CAN system, there are no transport addresses, but message identifiers. The message which is being sent can be received by all stations at the same time (broadcast).

By means of a special filter methods, the station only accepts the relevant messages. The identifier transmitted with the message is the basis for the decision as to whether the message will be accepted or not.

The bus coupler is standardised according to the international standard ISO-DIS 11898 (CAN High Speed) standard and allows data to be transferred at a maximum rate of 1 MBit/ s. The most significant feature of the CAN-protocol is its high level of transmission reliability (Hamming distance = 6).

The CAN-Controller Intel 82527 used in the encoder is **basic** as well as **full-CAN** compatible and supports the **CAN-specification 2.0 part B (standard protocol with 11-bit- identifier** as well as **extended protocol with 29-bit identifier)**. Up to now, only 11-bit identifiers have been used for CANopen.

### FIELD OF APPLICATION

In systems, where the position of a drive or of any other part of a machine has to be recorded and signalled to the control system, the AC 58 can assume this function. The AC 58 can resolve, for instance, positioning tasks by sending the check-back signal concerning the present drive position via the CAN bus to the positioning unit.



# Basics of Absolute Encoders ACURO

## CANopen

### CANOPEN COMMUNICATION MODEL AND PROFILE

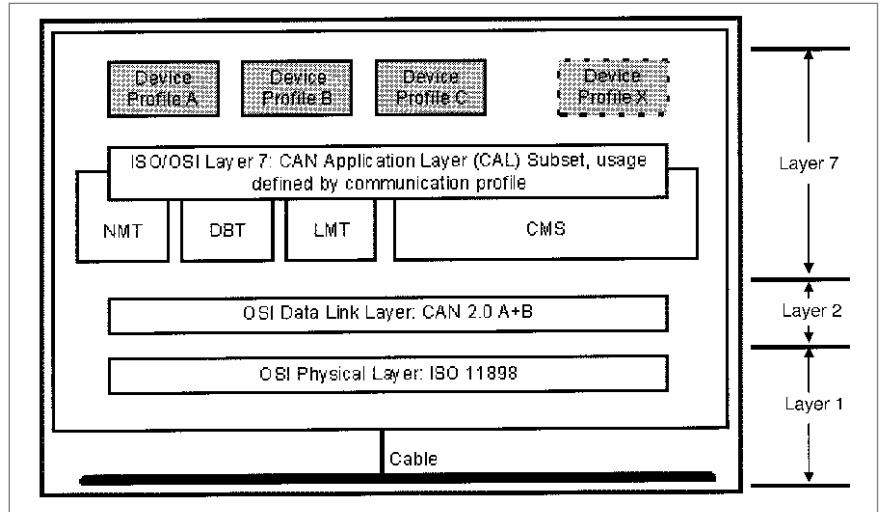

Layer 1 (Physical Layer): ISO-DIS 11898 (CAN High Speed)

Layer 2 (Data Link Layer): ISO-DIS 11898 (CAN High Speed)

Layer 7 (Application Layer): CiA DS 301 (CANopen CAL-based Communication Profile)  
+ Device profile CiA DS 4xx (CANopen Device Profile for xx)

For the following devices, profiles already exist:

- CiA Draft Standard Proposal 401 for Input/Output Modules
- CiA Draft Standard Proposal 402 for Drives and Motion Control
- CiA Work Item 403 for Human-Machine Interfaces
- CiA Work Draft 404 for Closed-Loop Controllers and Transformers
- CiA Work Item 405 for IEC-1131 Interfaces
- **CiA Draft Standard Proposal 406 for Encoders**
- CiA Work Item 407 for Public Transport
- CiA Work Item 408 for Fork-Lifts

## CANopen

### THE CANOPEN PROFILE

About two and a half years after the CiA, the association of the user and manufacturer of CAN products, had adopted the CAN Application Layer (CAL), CANopen and the respective device profiles paved the way for the development of open systems.

CANopen has been developed under the technical direction of the Steinbeis Transfer Centre for Automation (STA Reutlingen; Germany) on the basis of the layer 7 CAL specification.

Compared with CAL, CANopen only provides the functions needed for this special purpose. CANopen is thus a part of CAL which has been optimised for application purposes and allows for a simpler system structure as well as for simpler devices.

CANopen has been optimised for a quick transfer of data in real-time systems and has been standardised for different device profiles.

The CAN in Automation (CiA) association of users and manufacturers is responsible for the establishing and the standardisation of the respective profiles.

The RA58 with CANopen meets the requirements laid down in the communication profile (CiA DS 301) and in the device profile for encoders.

CANopen allows for:

- auto configuration of the network,
- comfortable access to all device parameters.
- synchronisation of the devices,
- cyclical and event-controlled process data processing,
- simultaneous data input and output.

CANopen uses four communication objects (COB) with different features:

- Process Data Objects (PDO) for real-time data
- Service Data Objects (SDO) for the transfer of parameters and programs
- Network Management (NMT, Life-Guarding)
- predefined objects (for synchronisation, time stamp, emergency message)

All device parameters are stored in an object directory. The object directory contains the description, data type and structure of the parameters as well as their addresses (index).

The directory consists of three parts: communication profile parameters, device profile parameters and manufacturer specific parameters.

### THE ENCODER DEVICE PROFILE (CIA DSP 406)

This profile describes a binding, but manufacturer-independent definition of the interface for encoders. The profile not only defines which CANopen functions are to be used, but also how they are to be used. This standard permits an open and manufacturer-independent bus system.

The device profile consists of two object categories

- the standard category C1 describes all the basic functions the shaft encoder must contain

- the extended category C2 contains a variety of additional functions which either have to be supported by category C2 shaft encoders (mandatory) or which are optional. Category C2 devices thus contain all C1 and C2 mandatory functions as well as, depending on the manufacturer, further optional functions.

Furthermore, an addressable area is defined in the profile, to which, depending on the manufacturer, different functions can be assigned.

## CANopen

### DATA TRANSFER

In CANopen, the data is transferred by means of two different communication types (COB = Communication Object) with different features:

- **Process Data Objects (PDO)**
- **Service Data Objects (SDO)**

The priority of the message objects is determined by the COB identifier.

The **process data objects (PDO)** serve the highly dynamic exchange of real-time data (e.g. position of the shaft encoder) with a maximum length of 8 Byte. This data is transferred with high priority (low COB identifier). PDOs are broadcast messages and put their information simultaneously at the disposal of all desired receivers.

The **service data objects (SDO)** form the communication channel for the transfer of device parameters (e.g. programming of the shaft encoders' resolution). Since these parameters are transferred acyclically (e.g. only once when running up the network), the SDO objects have a low priority (high COB identifier).

### COB IDENTIFIER

For an easier administration of the identifiers, CANopen uses the "Predefined master/Slave Connection Set"). In this case, all identifiers with standard values are defined in the object directory. However, these identifiers can be modified according to the customers' needs via SDO access.

The 11-bit identifier consists of a 4 Bit function code and a 7 Bit node number.

Bit-No.	10	9	8	7	6	5	4	3	2	1	0
Type	Function code				Node number						
Assignment <sup>1</sup>	x	x	x	x	0	0	x	x	x	x	x

<sup>1</sup> x = binary value can be selected freely 0 or 1); 0 = 0 value is fixed

**The higher the value of the COB identifier, the lower the identifier's priority!**

### NODE NUMBER

The 7-bit node number is set by means of the hardware via the 5 DIP switches on the encoder's back.



For further information see CAN user organisation:

[www.can-cia.de](http://www.can-cia.de)

# Basics of Absolute Encoders ACURO

## DeviceNet

### BACKGROUND AND TECHNOLOGY

#### Background

- The basic technology was developed by Allen-Bradley
- Introduced in March 1994
- The ODVA (Open DeviceNet Vendor Association) was founded in April 1995

#### Technology

- CAN-Layer 2 (Data Link Layer) - ISO 11898 and 11519-1
- DeviceNet covers layer 7 (Application Layer) and layer 1 (Physical Layer), developed for industrial automation

#### Main benefits

- Reduced cabling and installation effort
- Reduced run-in time
- Reduced down-time
- Fast error elimination
- Devices can be removed, replaced and inserted without having to shut the network down
- Devices from various manufacturers can be exchanged
- Devices are configured over the network

### LINEAR BUS TOPOLOGY

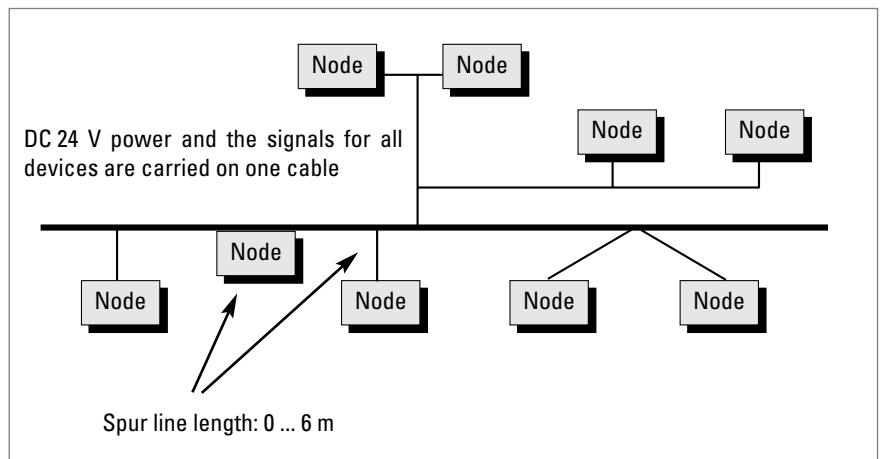

### NETWORK SPECIFICATION

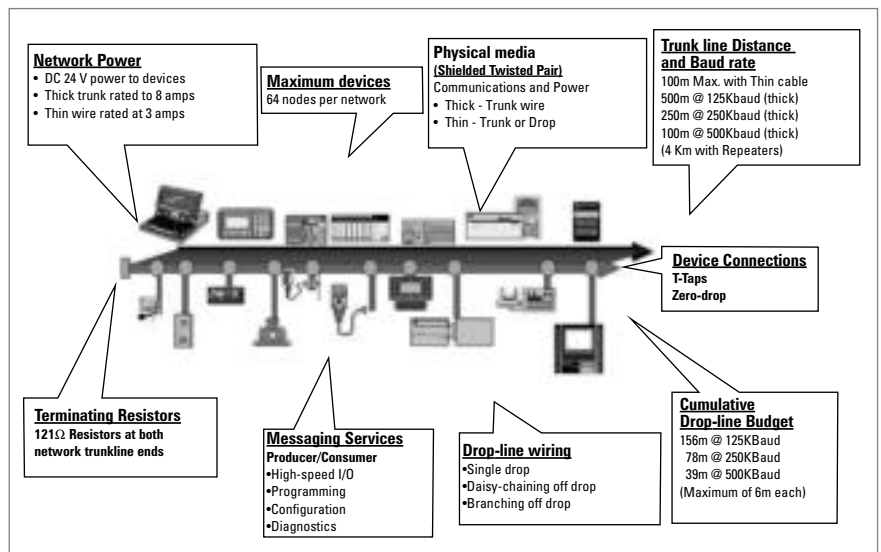

For more information about deviceNet please contact:

<http://www.odva.org>

e-mail: [odva@powerinternet.com](mailto:odva@powerinternet.com)

## Profibus-DP

### GENERAL INFORMATION

The basic functions of the PROFIBUS DP are here only described in extracts. For additional information, please refer to the standards on PROFIBUS DP, i.e. DIN 19245-3 and EN 50170 respectively.



### INTRODUCTION

The AC 58 is an absolute shaft encoder (encoder, angle encoder). The version described in this manual sends its current position to another station via the transmission medium "PROFIBUS DP" (physically: screened and twisted pair line). The AC 58 supports all class 1 and 2 functions listed in the encoder profile.

PROFIBUS-DP is manufacturer independent, open field bus standard for a variety of applications in the field of production, process and building services automation. The requirements of openness and independence from the manufacturer are stipulated in the European standard EN 50 170.

PROFIBUS-DP permits the communication of devices produced by different manufacturers without any particular adaptations of the interfaces.

PROFIBUS DP is a special standard version for a quick data exchange within the field level which has been optimised in terms of speed and low connection costs. Central control systems like, for example SPC/ PC communicate via a quick, serial connection with local field devices like drives, valves, or encoders. The data exchange between these devices is predominantly cyclical. The communication functions required for this exchange are determined by the basic functions of the PROFIBUS DP according to the EN 50 170 European standard.

### FIELD OF APPLICATION

In systems, where the position of a drive or of any other part of a machine has to be recorded and signalled to the control system, the AC 58 can assume this function.

The AC 58 can resolve, for instance, positioning tasks by sending the checkback signal concerning the present drive position via the PROFIBUS DP to the positioning unit.

### BASIC FUNCTIONS OF THE PROFIBUS-DP

The central control system (master) cyclically reads out the input information from the slaves and writes the output information to the slaves. For this purpose, the bus cycle time has to be shorter than the program cycle time of the central SPC, which amounts to approx. 10 ms for various applications.

Apart from the cyclical user data transfer, the PROFIBUS DP version also disposes of powerful functions for diagnosis and initial operation procedures. The data traffic is controlled by watchdog functions on both the slave and the master side. The following table summarises the basic functions of the PROFIBUS DP.

# Basics of Absolute Encoders ACURO

## Profibus-DP

Transmission technology:	<ul style="list-style-type: none"><li>• RS-485 twisted pair line</li><li>• Baud rates ranging from 9.6 kBit/s up to 12 MBit/s</li></ul>
Bus access:	<ul style="list-style-type: none"><li>• Token passing procedure between the masters and master-slave procedures for slaves</li><li>• Monomaster or multimaster systems possible</li><li>• master and slave devices, max. of 126 stations at a single bus</li></ul>
Communication:	<ul style="list-style-type: none"><li>• Point-to-point (user data communication) or multicast (control commands)</li><li>• cyclical master-slave user data communication and acyclical master-master data transfer</li></ul>
Operating state:	<ul style="list-style-type: none"><li>• Operate: cyclical transfer of input and output data</li><li>• Clear: The input data are read, the output data remain in the safe status</li><li>• Stop: only master-master data transfer is possible</li></ul>
Synchronisation:	<ul style="list-style-type: none"><li>• Control commands enable a synchronisation of the input and output data</li><li>• Sync mode: Output data are being synchronised</li></ul>
Functionality:	<ul style="list-style-type: none"><li>• Cyclical user data transfer between DP master and DP slave(s)</li><li>• Single DP slaves are dynamically activated or deactivated</li><li>• Control of the DP slave's configuration. Powerful diagnostic functions, 3 stepped diagnostic message levels.</li><li>• Synchronisation of in- and/ or output</li><li>• Address assignment for the DP slaves via the bus</li><li>• Configuration of the DP masters (DPM1) via the bus</li><li>• Maximum of 246 byte input and output data per DP slave possible</li></ul>
Protection functions:	<ul style="list-style-type: none"><li>• All messages are transferred with a hamming distance of HD=4</li><li>• Response control at the DP slaves</li><li>• Access protection of the DP slaves' input/ output</li><li>• Monitoring of the user data communication with adjustable control timer at the master</li></ul>
Device types:	<ul style="list-style-type: none"><li>• DP master class 2 (DPM2), e.g. programming/ project planning devices</li><li>• DP master class 1 (DPM1), e.g. central automation devices like SPC, PC</li><li>• DP slave e. g. devices with binary or analogue input/ output, drives, valves</li></ul>

### ESSENTIAL FEATURES/SPEED

The PROFIBUS DP only requires approx. 1 ms at a speed of 12 MBit/s in order to transfer 512 Bit input and 512 Bit output data by means of 32 stations.

The following diagram shows the usual PROFIBUS DP transfer time interval in relation to the number of stations as well as the transmission speed. The high speed can be above all explained by the fact that the input and output data within a message cycle are transferred by using the layer 2 SRD service (Send and Receive Data Service).

### Diagnostic function:

The comprehensive diagnostic functions of PROFIBUS DP allow a quick localisation of the errors. The diagnostic messages are transferred by means of the bus and are assembled at the master. They are subdivided in three levels:

## Profibus-DP

### BASIC FEATURES/SPEED

#### Station-related diagnosis

Messages on the general readiness for service of a station, like for example, overtemperature or undervoltage.

#### Channel related diagnosis

The error cause in relation to a single input/output bit (channel) is indicated here, like for example, a short-circuit at output line 7.

#### Module-related diagnosis

These messages indicate that a diagnosis within a certain I/O part (e.g. 8 Bit output module) of a station is in hand.

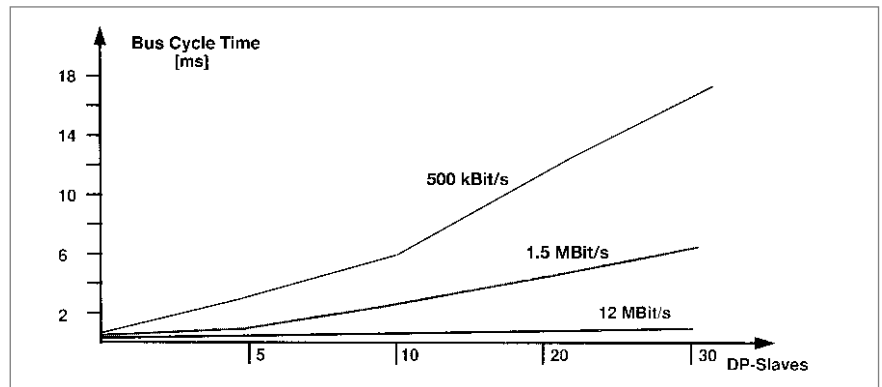

Bus cycle time of a PROFIBUS DP monomaster system

Boundary conditions: Each slave has 2 byte input and 2 byte output data; the minimum slave interval time amounts to 200 microseconds; TSDI = 37 Bit times, TSDR = 11 Bit times

### CONFIGURATION OF THE SYSTEM AND DEVICE TYPES

By means of PROFIBUS DP, mono- and multimaster systems can be realised. For this reason, a high level of flexibility in terms of the system configuration can be achieved. A maximum of 126 devices (master or slaves) may be connected to a bus. The definitions for the system configuration contain the number of stations, the assignment of the station address to the I/O addresses, the data consistency of the I/O data, the format of the diagnostic messages and the bus parameters used. Each PROFIBUS DP system consists of different device types. There are three device types to be distinguished:

#### DP master class 1 (DPM1)

These devices are central control systems exchanging information with the local stations (DP slaves) during a fixed message cycle. Typical devices of this kind are stored-program controllers (SPC), PC or VME systems.

#### DP master class 2 (DPM2)

Programming, configuration devices, and operator panels belong to this category. They are used for the initial operation procedures in order to establish the configuration of the DP system, or to operate the plants in the course of operation.

#### DP slave

A DP slave is a peripheral I/O rack (I/O, drives, HMI, valves) that reads the input information and sends output information to the peripheral equipment. Devices which provide only input or only output information might also be used.

The amount of input and output information is device specific and must not exceed 246 byte for the input and 246 byte for the output data.

# Basics of Absolute Encoders ACURO

## Profibus-DP

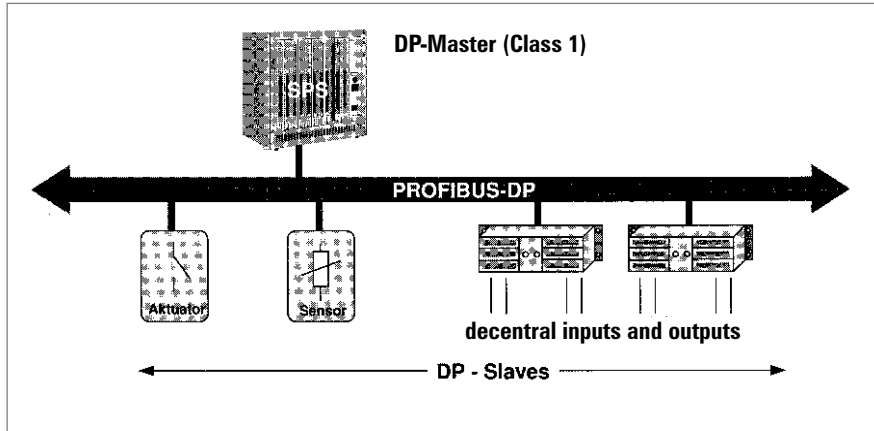

### PROFIBUS DP monomaster system

In the case of monomaster bus systems, there is only one master active at bus during the on-line phase of the bus system. The above diagram shows the system configuration of a monomaster system.

The SPC based control system is the central control element. By means of the transmission medium, the DP slaves are locally linked to the SPC control system. By using this system configuration, the shortest bus cycle time can be obtained.

In the multimaster mode, several masters are linked to a single bus. They either form independent subsystems consisting of one DPM1 and its corresponding DP slaves each, or additional configuration and diagnostic devices (see diagram below). The I/O maps of the DP slaves can be read by all DP masters, but only one DP master, the one which has been assigned DPM1 during project planning, is able to write the output information. Multimaster systems attain a medium bus cycle time.

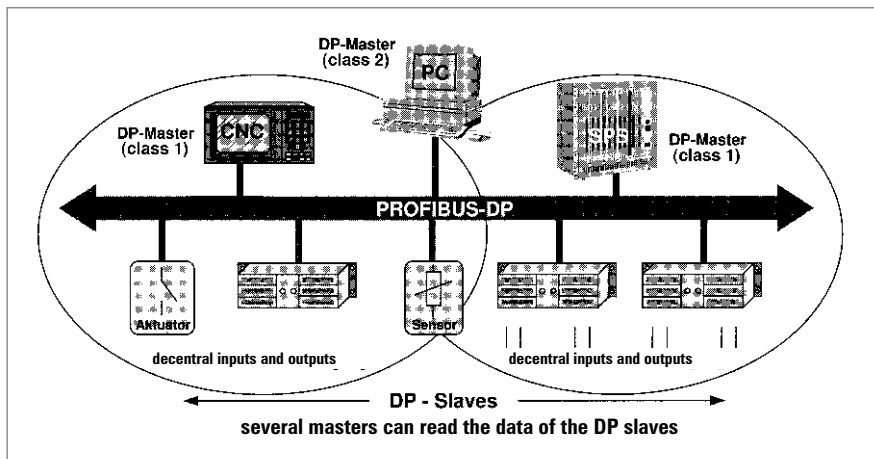

PROFIBUS-DP Multi-Master System



## Profibus-DP

### SYSTEM PERFORMANCE

In order to obtain a high level of exchangeability between the devices, the system performance of PROFIBUS DP has also been standardised. It is mainly determined by the operational status of the DPM1.

**The DPM1** can either be controlled locally or via the bus by the project planning device. The following three main states can be distinguished:

#### Stop

There is no data traffic between DPM1 and the DP slaves.

#### Clear

The DPM1 reads the input information of the DP slaves and maintains the safe status of the DP slaves' output.

#### Operate

The DPM1 has entered the data transfer phase. In case of a cyclical data traffic, the input is read by the DP slaves while the output is transferred to the DP slaves.

After an error has occurred during the data transfer phase of the DPM1, like for example, the failure of a DP slave, the response of the system is determined by the operating parameter "Auto Clear".

If this parameter has been set to true, the DPM1 will set the output of all the respective DP slaves to the safe status, as soon as a DP slave is no longer available for user data communication. Afterwards, the DPM1 changes to the clear status.

If this parameter is = false, the DPM1 remains, even if an error occurs, in the operate status, and the user can determine the response of the system at his own discretion.

### CYCLICAL DATA TRANSFER BETWEEN DPM1 AND THE DP SLAVES

The data traffic between the DPM1 and the respective DP slaves is automatically handled by the DPM1 in a fixed, recurring order. When configuring the bus system, the user assigns a DP slave to the DPM1. In addition, the slaves to be included in- or excluded from the user data communication are defined.

The data traffic between the DPM1 and the DP slaves is subdivided in parametrisation, configuration, and data transfer phases. Before including a DP slave in the data transfer phase, the DPM1 checks during the parametrisation and configuration phase, whether the planned set configuration corresponds to the actual configuration of the device.

For this check, the device type, the information on the format and the length as well as the number of input and output lines have to be correct. The user thus obtains a reliable protection against parametrisation errors. In addition to the user communication, which is automatically executed by the DPM1, the user may request the new parametrisation data to be sent to the DP slaves.

# Basics of Absolute Encoders ACURO

## Profibus-DP

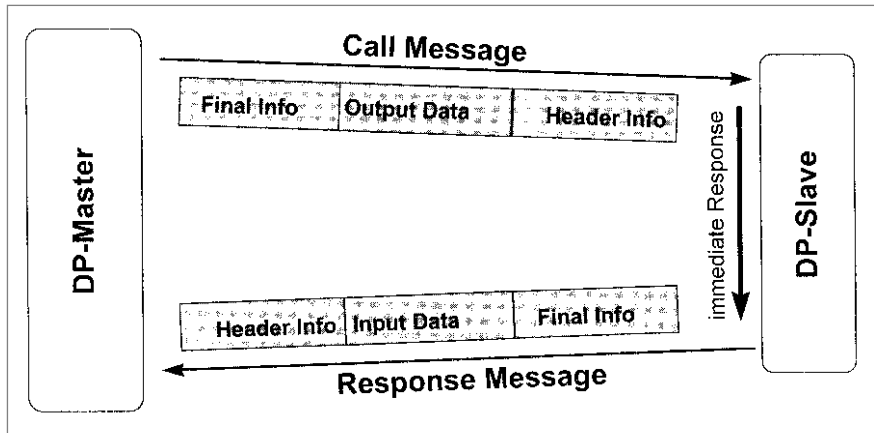

User data communication for PROFIBUS-DP

### DATA TRAFFIC BETWEEN DPM1 AND PROJECT PLANNING DEVICES

In addition to the functions between DP master and DP slaves, master-master communication functions are available, see table. They support the project planning and diagnostic devices in projecting the system via the bus.

Besides the upload and download functions, the master-master functions offer the opportunity to switch the user data transfer between the DPM1 and the single DP slaves dynamically on or off as well as to modify the operating status of the DPM1.

Function	Meaning	DPM1	DPM2
<b>Get_master_Diag</b>	reads the diagnostic data of the DPM1 or the collective diagnosis of the DP slaves.	M	0
<b>Download / Upload Group (Start_Seq, Down-/Upload, End_Seq)</b>	reads or writes the entire configuration data of a DPM1 and of the respective DP slaves.	0	0
<b>Act_Para_Brct</b>	activates the bus parameters for all operating DPM1 devices.	0	0
<b>Act_Param</b>	activates parameters or modifies the operating status of the operating DPM1 device.	0	0

M: mandatory, 0: optional

Functional overview for the master-master functions for PROFIBUS DP

## Profibus-DP

### SYNC MODE

In addition to the station-related user data communication being automatically handled by the DPM1, the masters may send control commands to a single slave, a group of slaves or all slaves at the same time. These control commands are transferred as multicast. It is only by means of this multicast that the sync and freeze operating modes for the event-controlled synchronisation of the DP slaves have been enabled.

The sync mode is started by the slaves, as soon as they receive a sync command from the respective master. The output lines of the addressed slaves will then be frozen in their current state. The output data will be stored at the slaves during the following user data transfers; the state of the output lines, however, will remain unchanged. Unless the next sync command has been received, the stored output data will not be connected to the output lines. By selecting unsync, the sync mode is terminated.

### PROTECTIVE MECHANISMS

For reasons of safety, it is necessary to equip PROFIBUS DP with powerful protective functions against false parametrisation or failure of the transmission equipment. For this purpose, control mechanisms at the DP master and the DP slave have been realised, taking the form of time-out circuits. The monitoring interval is determined during project planning.

#### At the DP master

The DPM1 controls the data traffic of the slaves by means of the Data\_Control\_Timer. For each slave, a special timer is used. The time-out circuit will respond, if no proper user data transfer occurs during a control interval. In this case, the user will be informed. If the automatic response to an error (Auto\_Clear = True) has been released, the DPM1 will quit the operate status, switch the output lines of the respective slaves to the safe status and change to the clear status.

#### At the DP slave

In order to recognise errors by the master or transmission errors, the slave executes the response control. If there is no data traffic during the response control interval, the slave will automatically switch the output lines to the safe status.

When operating in multimaster systems, a supplementary access protection for the I/O lines of the slaves will be necessary. This is to make sure that direct access can only be gained by an authorised master. For all the other masters, the slaves will provide an I/O map which can be also be read without access authorisation.

### COMMUNICATION INTERFACE

The communication interface corresponds to the PROFIBUS DP class 2 encoder profile.

Within this interface the class 1 functions are included.



For further information see:  
[www.profibus.de](http://www.profibus.de)

## Glossary of Technical Terms

Absolute shaft encoder	Shaft encoder that transmits unique coded data for each increment.
Accuracy	The difference between the actual and measured position.
Alarm signal	Serves to monitor the shaft encoder for malfunctions, such as glass breakage, fouling, short circuit, short circuit of signal line, and supply voltage too low.
Amplitude regulation	Current or voltage amplitude is constant through regulation
Analogue signal	A signal whose level alters continuously.
ASIC	Application specific integrated circuit
Axial loading	Maximum load on the shaft encoder's shaft in the axial direction
Bandwidth	Frequency range for output signals
Baud rate	Rate of data transfer (bits per second).
BCD	Binary-coded decimal; binary representation of a decimal number.
Binary	Two logical states (yes/no); the basis of binary data-processing systems.
Binary code	Code using binary numbering; often used for absolute measuring systems.
Bit	Abbreviation for "binary digit"; the smallest unit of information of a binary system, whose value can be 1 or 0 (yes-or-no decision).
Bus cycle	Time needed for polling every bus slave by the bus master.
Byte	Sequence of 8 Bits.
CAL	Can application layer
CANopen	Layer 7 protocol based on CAN
CCW	Counter clockwise
Change of state	For CAN: Bus node (encoder) sends it's data automatically when a position change occurs.
Channel	Signal track on which 1 or 0 is outputted.
CiA	CAN in automation (CAN users and manufacturers group)
CiA DS	CAN in automation draft standard, communication profile
CiA DSP	CAN in automation draft standard proposal, communication profile
CIM	Computer Integrated Manufacturing; i. e. the linking of different computer-aided processes in production and related fields for general use of the data.
CMD	Software tool for configuration and diagnosis of Interbus networks
COB	Communication object
Code	Format in which data are transmitted.
Code switching frequency	Number of position steps per second. For absolute shaft encoders with parallel interface: The maximum output frequency of the LSB output driver ( $f_{max}$ ) also limits the maximum permissible code switching frequency: Code switching frequency max. = $2 \cdot f_{max}$ for Binary code Code switching frequency max. = $4 \cdot f_{max}$ for Gray code

## Glossary of Technical Terms

Coefficient of thermal expansion	Material expansion under influence of temperature change [ $\mu\text{m}/^\circ\text{K m}$ ], relevant for linear scales.
Complementary	Output circuit for which also the inverted signals are outputted (e.g. Channel A and Channel A). Electrically, the 1/0 levels are transmitted as voltage differences between two lines. In this way the information signal (the difference) remains pure as in general interferences are interspersed equally on both lines.
CRC	Cyclic redundancy check. Bit error protection method for data communication.
CW	Clockwise
Data bus	System of lines over which data are transferred electronically in parallel or serially.
Data consistency	Intrinsic coherence of data in respect of timing and logical aspects.
Data integrity	Correspondence of data with the reality that they describe.
Datavalid	Output for checking the validity of data.
DC	Direct current (not alternating)
Demodulator	Device that filters the original information out of an altered signal again.
DeviceNet - conformity and interoperability	Confirmation of agreement of a bus node with the DeviceNet specifications and correct interoperability with other DeviceNet nodes.
Differential line driver	Output circuit in which the difference between the two signals A and A is evaluated, thus providing high signal transmission reliability.
DIN	Deutsche Industrie Norm (German Industrial Standard)
Direction	Control input for determining the data sequence (whether ascending for clockwise or counterclockwise rotation).
Dual Code	Natural binary code
EDS - File	Electronic data sheet. This is a file with the device specific parameter description and is provided by the manufacturer of a DeviceNet or CANopen device.
EEPROM	"Electrically Erasable Programmable Read-Only Memory" chip (see EPROM).
EIA	Electronic Industries Association; U.S. umbrella organization of manufacturers of electronic equipment and facilities. It is responsible for maintenance and development of the industrial standards for interfaces between data-processing devices and data communications equipment.
EMC	Electromagnetic compatibility
ENCOM	User group of manufacturers of INTERBUS-S absolute shaft encoders
Encoder monitoring	See "Alarm signal"
Enable	Control input via which the data outputs can be activated.
Encoder power	Supply voltage to be provided for the shaft encoder.
EPROM	"Erasable Programmable Read-Only Memory" chip, which can be erased with ultraviolet light, after which new data can be written into it.
Gray code	A special binary code that changes only one data bit per measuring step at a time. It is used with absolute encoders.

# Glossary of Technical Terms

Hamming distance	Measure for data security in a data transmission. The higher the number the better the ability to detect data errors.																												
Harmonic Distortion	Measure for the signal quality of sinewave encoder [%]. It describes the content of harmonics in analogue signals. The lower the number the better the signal.																												
Hysteresis error	Measurement deviation for a position approached from opposite directions.																												
Identifier	Address of a message in a CAN network.																												
IEC	International Electrotechnical Commission; organization promoting international standardization of electrical components.																												
Immunity to interference	<p>Test procedure according to IEC 801, Part 4</p> <p>– A test of susceptibility to fast electrical transients (bursts) causing interference on lines.</p> <p>The test values are divided into 5 levels:</p> <table border="1" style="width: 100%; border-collapse: collapse;"> <thead> <tr> <th style="text-align: left;">Level</th> <th style="text-align: left;">Mains line</th> <th style="text-align: left;">Data and control lines</th> </tr> </thead> <tbody> <tr> <td>1</td> <td>0.5 kV</td> <td>0.25 kV</td> </tr> <tr> <td>2</td> <td>1.0 kV</td> <td>0.5 kV</td> </tr> <tr> <td>3</td> <td>2.0 kV</td> <td>1.0 kV</td> </tr> <tr> <td>4</td> <td>4.0 kV</td> <td>2.0 kV</td> </tr> <tr> <td>X</td> <td>special</td> <td>special</td> </tr> </tbody> </table> <p>– Test procedure according to IEC 801, Part 2</p> <p>Discharge of static electricity on the surface and in the surroundings of the specimen. The test values are divided into 4 classes:</p> <table border="1" style="width: 100%; border-collapse: collapse;"> <thead> <tr> <th style="text-align: left;">Class</th> <th style="text-align: left;">test voltage</th> </tr> </thead> <tbody> <tr> <td>1</td> <td>2 kV</td> </tr> <tr> <td>2</td> <td>4 kV</td> </tr> <tr> <td>3</td> <td>8 kV</td> </tr> <tr> <td>4</td> <td>15 kV</td> </tr> </tbody> </table> <p>– Radio interference voltage test to VDE 0871.</p>	Level	Mains line	Data and control lines	1	0.5 kV	0.25 kV	2	1.0 kV	0.5 kV	3	2.0 kV	1.0 kV	4	4.0 kV	2.0 kV	X	special	special	Class	test voltage	1	2 kV	2	4 kV	3	8 kV	4	15 kV
Level	Mains line	Data and control lines																											
1	0.5 kV	0.25 kV																											
2	1.0 kV	0.5 kV																											
3	2.0 kV	1.0 kV																											
4	4.0 kV	2.0 kV																											
X	special	special																											
Class	test voltage																												
1	2 kV																												
2	4 kV																												
3	8 kV																												
4	15 kV																												
Incremental measuring system	Measuring method in which the variable is formed by counting increments (measuring steps).																												
Incremental shaft encoder	Shaft encoder which transmits an electrical signal (yes/no) for each increment, determined by the marked disc.																												
Integer	Integral values; range of values at n bit: 0 ... (2 <sup>n</sup> -1)																												
Integrated coupling	Flexible coupling built into shaft encoders																												
INTERBUS	Real time bus for the sensor-actor-level																												
Interbus-Loop	Two wire version of Interbus, transmitting data over the power supply lines and using Phoenix Contact "Quickon" cable plugs.																												
Interface	Transfer point with certain terminals, signals, or signal sequences. The interface serves for communication of the shaft encoder with other systems.																												
Interpolation	Scanning of a sinewave signal to increase resolution by generating intermediate position values.																												
IP	See "Protection class"																												
Jitter	Change in the phase angle between Channel A and B within one revolution (360°).																												
Latch	Control input for storing ("freezing") the data before they are read out.																												

## Glossary of Technical Terms

Linearity	Deviation of the reading from the actual value within one revolution (360°).																												
Line driver	Output circuit that makes a larger current possible.																												
LSB	Least Significant Bit																												
Measuring wheel	A wheel that, mounted on a shaft encoder, converts a linear motion into a rotary motion.																												
MSB	Most Significant Bit																												
MTBF	“Mean Time Between Failures”, a measure of average service life.																												
Multi-turn shaft encoder	Shaft encoder which transmits the number of shaft revolutions as well as the angular position of the shaft.																												
NC machinery	Numerically Controlled machinery; their movements are programmed.																												
NPN input/output	Transistor input/output circuit implemented with an npn transistor, and thus negative switching.																												
Offset	For programmable absolute shaft encoders: the offset value is added to the value of physical position. As a result you get a relative shift of the output value (output value = position value + offset value).																												
Parallel interface	Transfer point at which the data are transferred in parallel over several lines.																												
Parity	Checkbit for error detection in data transfer																												
PDO	Process data object (in CAN networks)																												
P.L.C.	Programmable Logic Controller: control system whose program is stored in a program memory and can be changed.																												
Phase discriminator	Sense-of-direction detector that functions by evaluating the phase angle between Signal A and Signal B.																												
Phase tolerance	Deviation of the pulse-edge from Channel A to B, relative to the phase angle 90°.																												
PNP input/output	Transistor input/output circuit implemented with a pnp transistor, and thus positive switching.																												
Preset	For programmable absolute shaft encoders: The programmed numerical value is accepted as output value (output value = preset value).																												
Protection class	<p>The enclosure class is designated according to DIN 40050, by IP and a two-figure code number.</p> <table> <tr> <td>1st digit</td> <td>Degree of protection against ingress of solid bodies:</td> </tr> <tr> <td>0</td> <td>no special protection</td> </tr> <tr> <td>1</td> <td>solid bodies with dia. &gt; 50 mm, no protection against intentional penetration</td> </tr> <tr> <td>2</td> <td>solid bodies with dia. &gt; 12 mm, warding off fingers etc.</td> </tr> <tr> <td>3</td> <td>solid bodies with dia. &gt; 2.5 mm, warding off tools, wires, etc. (thickness &gt; 2.5 mm)</td> </tr> <tr> <td>4</td> <td>solid bodies with dia. &gt; 1 mm, warding off tools, wires, etc. (thickness &gt; 1 mm)</td> </tr> <tr> <td>5</td> <td>dust in harmful quantities, complete shock-hazard protection</td> </tr> <tr> <td>6</td> <td>dust (dust-tight), complete shock-hazard protection</td> </tr> <tr> <td>2nd digit</td> <td>Degree of protection against water</td> </tr> <tr> <td>0</td> <td>no special protection</td> </tr> <tr> <td>1</td> <td>water dripping vertically</td> </tr> <tr> <td>2</td> <td>water dripping at angles up to 15° from vertical</td> </tr> <tr> <td>3</td> <td>water dripping at angles up to 60° from vertical (spraying water)</td> </tr> <tr> <td>4</td> <td>water from all directions (splashing water)</td> </tr> </table>	1st digit	Degree of protection against ingress of solid bodies:	0	no special protection	1	solid bodies with dia. > 50 mm, no protection against intentional penetration	2	solid bodies with dia. > 12 mm, warding off fingers etc.	3	solid bodies with dia. > 2.5 mm, warding off tools, wires, etc. (thickness > 2.5 mm)	4	solid bodies with dia. > 1 mm, warding off tools, wires, etc. (thickness > 1 mm)	5	dust in harmful quantities, complete shock-hazard protection	6	dust (dust-tight), complete shock-hazard protection	2nd digit	Degree of protection against water	0	no special protection	1	water dripping vertically	2	water dripping at angles up to 15° from vertical	3	water dripping at angles up to 60° from vertical (spraying water)	4	water from all directions (splashing water)
1st digit	Degree of protection against ingress of solid bodies:																												
0	no special protection																												
1	solid bodies with dia. > 50 mm, no protection against intentional penetration																												
2	solid bodies with dia. > 12 mm, warding off fingers etc.																												
3	solid bodies with dia. > 2.5 mm, warding off tools, wires, etc. (thickness > 2.5 mm)																												
4	solid bodies with dia. > 1 mm, warding off tools, wires, etc. (thickness > 1 mm)																												
5	dust in harmful quantities, complete shock-hazard protection																												
6	dust (dust-tight), complete shock-hazard protection																												
2nd digit	Degree of protection against water																												
0	no special protection																												
1	water dripping vertically																												
2	water dripping at angles up to 15° from vertical																												
3	water dripping at angles up to 60° from vertical (spraying water)																												
4	water from all directions (splashing water)																												

## Glossary of Technical Terms

Protection class (continued)	<p>2nd digit Degree of protection against water</p> <p>5 water from a nozzle from all directions (hose-water)</p> <p>6 heavy seas or strong jet of water (flooding)</p> <p>7 water, if the device is immersed in water under specified conditions of pressure and time (immersion)</p> <p>8 water, if the device is submerged constantly. The manufacturer must describe the conditions (submersion)</p> <p>(For numbers 1 to 8, water must not penetrate in harmful quantities.)</p> <p>Example: IP65 A device thus designated is dust-tight, and protected against hose-water.</p>
PVC	Polyvinylchloride; plastic coating of device cable
PTB approval	Approval for use by the Physikalisch-Technische Bundesanstalt, the German government materials testing institute.
Pulse (repetition) frequency, max. speed	The maximum signal frequency achievable by the shaft encoder, the product of rotary and number of markings.
Radial load, max.	Maximum loading of shaft encoder shaft in radial direction.
Quickon	Connector with self contacting cable cutting contacts from Phoenix Contact used with Interbus Loop
RAM	"Random Access Memory" chip; this memory can be read from, written to, and erased freely. When the power goes off, it loses its information.
Reference mark	Irregular gradation pattern that generates a single signal peak, to provide an absolute reference for an incremental shaft encoder.
Reference pulse	Square-wave signal generated by a reference mark, usually only one increment wide, to provide an absolute reference for an incremental shaft encoder.
Repeatability	Degree of deviation for a point approached repeatedly under identical operating conditions.
Resolution	Number of increments per revolution (rotary) or distance between two increments (linear)
Resolver	Inductive angular measuring device that generates two alternating voltages, with amplitude a function of the angle.
Reversal error	Deviation in reading of a position when approached from different directions (hysteresis).
ROM	"Read-Only-Memory" chip, whose memory can only be read out.
RS 422	Standardized interface for unidirectional point-to-point connections (for description refer to "Complementary"); voltage difference 7 V DC max.
RS 422/485	Interfaces for serial data transfer with specifications to EIA standards.
RS 485	Like RS 422, however as a bidirectional bus interface
Sampling frequency	Number of signal periods per second. The maximum sampling frequency limits the speed of incremental measuring systems.
SDO	Service data object (in CAN networks)
Sense	The Sense lines (Sense VCC and Sense GND) enable measurement of the factual encoder voltage without adulteration by voltage drop due to supply current and cable resistivity. With that e.g. supply voltage can automatically be adjusted.



## Glossary of Technical Terms

Scaling	For programmable absolute shaft encoders the encoder actual value is multiplied by a scaling factor. Thus the resolution (increments per measuring distance or increments per revolution) is adaptable to the respective application.
SSI	Synchronous-serial Interface; standardized interface for serial data transfer
TPE	Thermo-plastic polyester elastomer; plastic coating of device cable
Tristate	Control input; switches the outputs either to active or to high impedance.
Two's complement	Number format for the representation of negative numbers; range of values at n bit: $-(2^n - 1) \dots 0 \dots (2^{n-1} - 1)$

# Sales and Service international

Argentina	Zeising y Cia. S.A. Perú 245, C.P. (C1067AAE) Buenos Aires Tel. (5411) 4345-2321 Fax (5411) 4331-6291 zeising@ssdnet.com.ar http://www.zeising.com.ar/	Chile	Vignola y Cia. Ltda. P.O. Box 93-V CPIO-Subida El Peral 25 Valparaiso Tel. 0056-3225-6521 Fax 0056-3225-8571 vignola@entelechile.net	Denmark	J.D. Friderichsen A/S Sydmarken 46 2860 Søborg Phone +457 027 2327 Fax +457 027 2337 http://www.jdf.dk jdf@jdf.dk		
Australia	Automated Control Engineering Group Pty Ltd. Unit 1, 64 Munibung Road Cardiff NSW 2285 Tel. +61-2- 4954 5004 Fax +61-2- 4956 7686 phil@aceg.com.au http://www.aceg.com.au/  Koloona Industries 2/17 Pembury Road Minto 2566 Tel. +61 2 9820 5233 Fax +61 2 9820 5244 http://www.koloona.au sales@koloona.com.au	China	Automate Control Engineering Ltd. Room G, 16/F.,No.1 Building, No. 445,Tian He Bei Road, Guangzhou Guangdong Provice. Tel: (020) 38845119 Fax: (020) 38823577 guangzhou@automate-ace.com www.automate-ace.com  Automate Control Engineering Ltd. 702 room, Tower 9 , No 228 Guangxi North Road, Huangpu Borough Shanghai Tel. +86 20 3884 5119 Fax +86 20 3882 3577 http://www.automate-ace.com shanghai@automate-ace.com  Beijing Westman Automation Technology Lt. Co Room 1207, Xuezhixuan Building No. 16 Xueqing Road Haidian District Beijing 100083 PR China Tel: 86-10-82755948 Fax: 86-10-82755951 sales@westmaninc.com	El Salvador	Automatización y Control Industrial de El Salvador, S.A. de C.V. Alameda Roosevelt y 53 Avenida Norte No. 131 Colonia Flor Blanca San Salvador El Salvador Tel.: +(503) 2 260-2424 Tel.: +(503) 2 260-2163 Tel.: +(503) 2 260-7986 Fax: +(503) 260-5686 acisa@telemovil.net	Estonia	Sakala Tööstusautomatika As Kallaste Keskus 9 Tabasalu, Harjumaa http://www.sakt.ee sakt@sakt.ee
Austria	Tischer Handels GmbH Industriestr. 23 A-2353 Guntramsdorf Tel. 0043-(0) 2236-89 3323-0 Fax 0043-(0) 2236-893323-40 office@tischer.at Mobil: 0043-676-7503925	Croatia	SMD Elektronik d.o.o. Vocarska 22 100000 Zagreb Tel. +385 1 4635481 Fax +385 1 4636888 smd-elektronik@zg.t-com.hr  Tipteh Zagreb d.o.o. Pešæanska 170 1000 Zagreb Hrvatska Tel.:+385 (1)381 65 74 Fax.:+385 (1)381 65 77 Mob.:+385 (91)381 65 74 http://www.tipteh.si tipteh.zagreb@zg.t-com.hr	Finland	Sensorola Oy Vanha Porvoontie 229 01380 Vantaa Tel. 0358-9-8386460 Fax 0358-9-8572205 myynti@sensorola.fi http://www.sensorola.fi/  Melart Electronics Masalantie 375 02430 Masala Phone +358 9 22 19 14 00 Fax +358 9 22 19 14 44 nylund@nylund.fi	France	Hengstler Contrôle Numérique SARL Z.I. des Mardelles 94-106 Rue Blaise Pascal, B.P. 71 93602 Aulnay-sous-Bois, Cédex Tel. (01) 48795501 Fax (01) 48795561 http://www.hengstler.fr
Belgium	ISOTRON Systems BVBA Antwerpse Steenweg 45 B-2930 Willebroek, Belgium Tel.: +32-3450-7045 Fax: +32-3450-7046 http://www.isotron.eu	Czech Republic	SETRON, s.r.o. K Mejtu 11 142 00 Praha 4-Plsnice Tel. 00420-2-619 10 222 Fax 00420-2-619 10 225 Mobil: 00420-601-211 355 setron@setron.cz http://www.setron.cz - not for "Printers"	Greece	Control System Ltd. 13 Chlois st 546 27 Thessaloniki Tel. (031) 527228 Fax (031) 515495 info@controlsystem.gr  Micarelec Advanced Technologies Ltd. Electronic Components 16 Isminis Street 12241 Aegaleo Athens Phone +30 1 5 69 50 42 Fax +30 1 5 69 51 33 micarelec@hol.gr		
Brasil	HECON 2100 West Broad Street Elizabethtown, NC 28337 Tel 1: +1-732-528-7101 Tel 2: +1-910-862-5469 Fax : +1 910 862 5408 http://www.hecon.com info.hecon@hecon.com  Veeder Root do Brasil Com. e. Ind. Ltda. Rua Ado Benatti 92 Sao Paulo SP CEP 05037-904 Phone +55 11 3879 6600 Fax +55 1136119 82	Denmark	ICS Industriens problemløser A/S Holkebjergvej 79 5250 Odense SV Tel.: +45 6617 1074 Fax: +45 6617 1065 http://www.ics-as.dk ics@ics-as.dk				
Chile	HECON 2100 West Broad Street Elizabethtown, NC 28337 Tel 1: +1-732-528-7101 Tel 2: +1-910-862-5469 Fax : +1 910 862 5408 http://www.hecon.com info.hecon@hecon.com  Veeder Root do Brasil Com. e. Ind. Ltda. Rua Ado Benatti 92 Sao Paulo SP CEP 05037-904 Phone +55 11 3879 6600 Fax +55 1136119 82						

# Sales and Service international

Hong Kong	Automate Control Engineering Ltd Unit 1505 Entrepot Centre, 117 How Ming Street, Kwun Tong, Kowloon, Hong Kong Tel: 852-2342-7276 Fax: 852-2342-7229 ace@automate.corp.com.hk	Japan	Danaher ICG Japan Co. Ltd. 1-8-5, Asagayaminami Suginami-Ku Tokyo 166-0004 Tel. (03) 5306-0150 Fax (03) 5306-0160	Netherlands	Isotron Systems De Meerheuvel 6a 5221 EA 's-Hertogenbosch Phone +31 73 639 16 39 Fax +31 73 639 16 99 http://www.isotron.nl info@isotron.nl
Hungary	C+D Automatika KFT Postfach 156 1701 Budapest Tel. (0036) 1 2829 896 Fax (0036) 1 2823 125 cdaut@e-mail.inext.hu http://www.cdaut.hu/		Danaher ICG Japan Co. Ltd. 2-12-23, Minamikaneden Suita-shi Osaka 564-0044 Tel. (06) 6386-8001 Fax (06) 6386-5022 e-mailmaster@danaher.co.jp	New Zealand	EMC Industrial Group Ltd. P.O. Box 101444 NSMC, Auckland Tel. (09) 415 5110 Fax (09) 415 5115 sales@emc.co.nz
India	Proximon Controls Pvt. Ltd. 202, Krishna Laxmi Industrial Complex Pokhran Road No. 1 Vartak Nagar Thane - 400 606 Tel. 91-22 - 2588 92 44 / 45 91-22 - 2585 42 87 Fax. 91-22 - 2588 92 46 proximon@vsnl.com http://www.proximon.com/	Korea	Dae-Hyun Sangong Co., Ltd Room No.B-607, Woolimm Lions Valley. #371-62, Gasan-Dong, Geumcheon-Gu Seoul, Korea Tel. 0082-2-206-4321 Fax 0082-2-206-4322 cyberist@shinbiro.com	Norway	Hecotron Industriell Elektronik AS Postboks 4269, Torshöv Gunnar Schjelderupsv.9 04001 Oslo Tel. (22) 159 615 Fax (22) 22 93 65 hecotron@hecotron.no www.hecotron.no
India	<i>North India Territory.</i> Kudamm Corporation D-17, 11nd Floor, Kalkaji Opp.Nehru Place Bus Terminal New Delhi -110019, India Tel: 91-11-26423028 Fax: 91-11-26479097 Email: kudamm@vsnl.com www.kudammcorp.com		Wooil Engineering Room # 805, 302dong Bucheon Techno park, 365 Samjeongdong Ojeong-gu, Bucheon-si Kyunggi-do KOREA Tel: 82-2-652-5622 Fax: 82-2-652-5624 wooil@murr.co.kr www.murr.co.kr	Peru	Ing. E. Brammertz S.C.R.L. Apdo. 0173 Miraflores-Lima 18 Tel. +51-1-445 81 78 Fax +51-1-445 01 81 braming@mail.cosapidata.com.pe
Indonesia	Anugerah Abadi Lindeteves Trade Centre Lantai Dasar 1 (GF1) Blok B5 No.1 Jl. Hayam Wuruk 127 Jakarta Phone +6221 30012966 / 30012977 Fax +6221 30063835 iwanb@centrin.net.id	Lebanon	Incotel Electronics Facing Dora Gate Beirut Tel. 00961-1-240003 Fax 00961-1-252276 incotel@cyberia.net.lb www.incotel.com	Philippines	JMTI Industrial Corporation RM 203 Comfoods Building Sen. Gil Puyat Ave. Makati Metro Manila Tel. 0063-32-8446326 Fax 0063-32-3460763 jmti@info.com.ph
Israel	AM Components Ltd. 1 Ha'Nofar st. Ra'anana 43662 Israel Tel: +972 9 7458880 Fax: +972 9 7458881 sales@amcomp.co.il	Luxemburg	→ Belgium	Poland	Eltron pl.Wolnosci 7 B 50-071 Wroclaw Tel. 0048-71-343 97 55 Fax 0048-71-344 11 41 GF@eltron.pl www.eltron.pl
		Malaysia	FEG Components Sdn Bhd No. 6-2, (1st Floor), Jalan USJ 9/5N Subang Business Centre, UEP Subang Jaya 47620 Subang Jaya, Selangor Tel. 60-3-7245748 Fax 60-3-7245766 mg.chan@farnell-electronic.com	Portugal	Carlo Gavazzi Lda Rua dos Jeronimos 38-B 1400-212 Lisboa Tel. +351 21 361 70 60 Fax +351 21 362 13 73 carlogavazzi@carlo.gavazzi.pt
		Mexico	Compañía Ferretera Mexicana, CASA BOKER 16 de Septiembre 58 (esq. Isabela la Católica) Colonia Centro, Delegación Cuauhtémoc 06000, México D.F. Tel.: (52-55) 5512-2400 (52-55) 5518-3357 Fax: (52-55) 5521-1707 01-800-715-1307 info@boker.net	Romania	Tischer Handels GmbH Industriestr. 23 A-2353 Guntramsdorf Tel. +43 223 689 3323 0 Fax +43 223 689 3323 40 office@tischer.at
Italia	ICG Holding S.r.l. Via Leonardo da Vinci, 45/47 20020 Lainate (MI) Tel. 0039-02 9330011 Fax 0039-02 933001299 info@icg-holding.com				

# Sales and Service international

Serbia and Montenegro	Tipteh d.o.o. Beograd Bulevar AVNOJ-a 45D, lokal 18 11070 Novi Beograd Tel. +381 113 13 1057 Fax +381 113 01 8326 <a href="http://www.tipteh.co.yu">http://www.tipteh.co.yu</a> <a href="mailto:vecerka@ptt.yu">vecerka@ptt.yu</a>	Switzerland	Digana AG Rotackerstrasse 21 8304 Wallisellen Tel. (01) 8300893 Fax (01) 8300807 <a href="mailto:Info@digana.ch">Info@digana.ch</a> <a href="http://www.digana.ch/">http://www.digana.ch/</a>	USA	Barker Controls Inc. 2205 Old Buncombe Road Greenville SC 29609, USA Tel.: +1-864-233-2145 Fax: +1-864-242-1134 <a href="mailto:sales@barkercontrols.com">sales@barkercontrols.com</a>
Singapore	TDS Technology (S) Pte Ltd. 4 Sungei Kadut Loop (HOCEN Building, 3rd. Storey) Singapore 729493 Tel. (65) 366 1661 Fax (65) 362 1661 <a href="mailto:sales@tdstech.com">sales@tdstech.com</a> <a href="http://www.tdstech.com/">http://www.tdstech.com/</a>	Taiwan	King-E Lu Ltd. R. o. C. 10F-3, No. 20 Min Chuan West Road P.O. Box 68-118 118 Taipei Tel. (02) 25223056 Fax (02) 25319692 <a href="mailto:king.e@seed.net.tw">king.e@seed.net.tw</a>		Danaher Controls 1675 Delaney Road Gurnee, IL 60031-1282 Tel. (847) 662.2666 Fax (847) 662.6633 <a href="mailto:dancon@dancon.com">dancon@dancon.com</a> <a href="http://www.dancon.com/">http://www.dancon.com/</a>
Slovakia	Marpex, s.r.o. Športovcov 672 018 41 Dubnica nad Váhom Phone. +421 42 4440010-1 / +421 42 4426986-7 Fax +421 42 4440010-1 <a href="mailto:marpex@marpex.sk">marpex@marpex.sk</a>		<i>Distributor:</i> Rotech Enterprise Co. Ltd. 6F, No.3, Lane 26, Kuang-Fu N.Road Taipei Tel : 886-2-25781261 Fax : 886-2-25784348 <a href="mailto:E-KawaKami@tpts5.seed.net.tw">E-KawaKami@tpts5.seed.net.tw</a>		Dynapar 1675 Delany Road Gurnee IL 60031-1282 Tel. +1 847 6622666 Fax +1 847 6626633 <a href="mailto:custserv@dynapar.com">custserv@dynapar.com</a>
Slovenia	TIPTEH D.O.O. Ulica Ivana Roba 21 1000 Ljubljana Tel. (061) 200 51 50 Fax (061) 200 51 51 <a href="mailto:damijan.jager@abm.si">damijan.jager@abm.si</a> <a href="http://www.tipteh.si">http://www.tipteh.si</a>	Thailand	Industrial Electrical Co., Ltd. 85/2, 85/3 Soi Sot Phin San Rang Nam Road, Rajthevee 10400 Bangkok Tel. 66-2-642-6700 Fax 66-2-642-4250 <a href="mailto:iecl@ie.co.th">iecl@ie.co.th</a> <a href="http://www.ie.co.th/">http://www.ie.co.th/</a>		Force Guided Relays Int'l 161 Clear Road Oriskany, New York 13424 Tel.: 1 877 736 0304 Fax.: 1 315 736 0874 <a href="mailto:info@fgri.com">info@fgri.com</a>
South Africa	Countapulse Controls (Pty) Ltd. Cleveland, 2022 P.O. Box 40393 313 Jules Street Malvern, 2094 Tel. (011) 615 7556/7/8 Fax (011) 615 7513 <a href="mailto:countap@iafrica.com">countap@iafrica.com</a>  Avnet Kopp (Pty.) Ltd. P.O.Box 3853 ZA-2128 Rivonia Tel. +27 11 4 44 23 33 Fax +27 11 4 44 17 06 <a href="mailto:sales@avnetkopp.co.za">sales@avnetkopp.co.za</a>	Turkey	Alize, DIS Ticaret VE Mühendislik Ltd. STI. Bahçelievler Mah. ATA-2 Sitesi, Iğde Sk. No: 1 34680 Çengelköy - Üsküdar / ISTANBUL Tel: +90 216 486 33 01 Fax: +90 216 486 26 16 <a href="mailto:aize@alize.com.tr">aize@alize.com.tr</a>		HECON 2100 West Broad Street P.O. Box 368 Elizabethtown, NC 28337 Tel. 910.879.5493 Fax 910.862.5408 <a href="mailto:info.hecon@hecon.com">info.hecon@hecon.com</a> <a href="http://www.hecon.com">http://www.hecon.com</a> - only for Printers + Cutters
Spain	Carlo Gavazzi, S.A. Ava. Iparraguirre, 80-82 48940 Leioa (Bizkaia) Tel. 0034-94-480 40 37 Fax 0034-94-480 10 61 <a href="mailto:gavazzi@carlogavazzi-sa.es">gavazzi@carlogavazzi-sa.es</a> <a href="http://www.carlogavazzi.com/ac/es">http://www.carlogavazzi.com/ac/es</a>	U.A.E. United Arab Emirates	Descon Trading L.L.C P.O. Box 14675 Dubai Tel. 00971-4-2653651 Fax 00971-4-2653264 <a href="mailto:basusil@emirates.net.ae">basusil@emirates.net.ae</a>	Vietnam	Hoang Quoc Co. Ltd. 509 Kimma Str. Badinh District Hanoi-S.R.Vietnam Tel: 0084-4-8317421 Fax: 0084-4-8317433 <a href="mailto:hoangquoc@hn.vnn.vn">hoangquoc@hn.vnn.vn</a>
Sweden	ACUMO AB Hans Stahles väg S-14741 Tumba Tel. +46 8 53065840 Fax.+46 8 53034750 <a href="mailto:info@acumo.se">info@acumo.se</a> <a href="http://www.acumo.se">http://www.acumo.se</a>  AAAAA Nordic Ab Terminalgatan 1 23539 Vellinge Phone +46-4042 66 30 Fax +46-4042 66 33 <a href="mailto:bon@aaaaa.se">bon@aaaaa.se</a>	United Kingdom	Stanler Components Ltd. Crittall Court Crittall Drive Springwood Indust. Est. Essex CM 7 2SE Braintree Phone +44 13 76 34 09 02 Fax +44 13 76 32 25 10 <a href="mailto:sales@stanler.co.uk">sales@stanler.co.uk</a>		

# GENERAL CONDITIONS

## FOR THE SUPPLY OF PRODUCTS AND SERVICES OF THE ELECTRICAL AND ELECTRONICS INDUSTRY\*

for commercial transactions between businesses

– January 2002 –

### I. GENERAL

1. The scope of deliveries and/or services (hereinafter referred to as „Supplies“) shall be determined by the written declarations of both Parties. General terms and conditions of the Purchaser shall apply only if and when expressly accepted by the supplier or the provider of services (hereinafter referred to as „Supplier“) in writing.
2. The Supplier herewith reserves any industrial property rights and/or copyrights pertaining to its cost estimates, drawings and other documents (hereinafter referred to as „Documents“). The Documents shall not be made accessible to third parties without the Supplier's prior consent and shall, upon request, be returned without undue delay to the Supplier if the contract is not awarded to the Supplier. Sentences 1 and 2 shall apply mutatis mutandis to documents of the Purchaser; these may, however, be made accessible to third parties to whom the Supplier may rightfully transfer Supplies.
3. The Purchaser shall have the non-exclusive right to use standard software, provided that it remains unchanged, is used within the agreed performance parameters, and on the agreed equipment. The Purchaser may make one back-up copy without express agreement.
4. Partial Supplies shall be allowed, unless they are unreasonable to accept for the Purchaser.

### II. PRICES AND TERMS OF PAYMENT

1. Prices shall be ex works and exclude packaging; value added tax shall be added at the then applicable rate.
2. If the Supplier is also responsible for assembly or erection and unless otherwise agreed, the Purchaser shall pay the agreed remuneration and any incidental costs required, e. g. travel costs, costs for the transport of tools and equipment, and personal luggage as well as allowances.
3. Payments shall be made free Supplier's paying office.
4. The Purchaser may set off only those claims that are undisputed or against which no legal recourse is possible.

### III. RETENTION OF TITLE

1. Items pertaining to the Supplies („Retained Goods“) shall remain the property of the Supplier until each and every claim the Supplier has against the Purchaser on account of the business connection has been fulfilled. If the combined value of the security interests of the Supplier exceeds the value of all secured claims by more than 20 %, the Supplier shall release a corresponding part of the security interest if so requested by the Purchaser.
2. For the duration of the retention of title, the Purchaser may not pledge the Retained Goods or use them as security, and resale shall be possible only for resellers in the ordinary course of their business and only on condition that the reseller receives payment from its customer or makes the transfer of property to the customer dependent upon the customer fulfilling its obligation to effect payment.
3. The Purchaser shall inform the Supplier forthwith of any seizure or other act of intervention by third parties.
4. Where the Purchaser fails to fulfil its duties, including failure to make payments due, the Supplier shall be entitled to cancel the contract and take back the Retained Goods in the case of continued failure following expiry of a reasonable time set by the Supplier; the statutory provisions that a time limit is not needed remain unaffected. The Purchaser shall be obliged to surrender the Retained Goods.

### IV. TIME FOR SUPPLIES; DELAY

1. Times set for Supplies can only be observed if all Documents to be supplied by the Purchaser, necessary permits and releases, especially concerning plans, are received in time and if agreed terms of payment and other obligations of the Purchaser are fulfilled. Unless these conditions are fulfilled in time, times set shall be extended appropriately; this shall not apply where the Supplier is responsible for the delay.
2. If non-observance of the times set is due to force majeure such as mobilization, war, rebellion or similar events, e. g. strike or lockout, such time shall be extended accordingly.
3. If the Supplier is responsible for the delay (hereinafter referred to as „Delay“) and the Purchaser demonstrably suffered a loss therefrom, the Purchaser

may claim a compensation as liquidated damages of 0.5 % for every completed week of Delay, but in no case more than a total of 5 % of the price of that part of the Supplies which because of the Delay could not be put to the intended use.

4. Purchaser's claims for damages due to delayed Supplies as well as claims for damages in lieu of performance exceeding the limits specified in No. 3 above shall be excluded in all cases of delayed Supplies even upon expiry of a time set to the Supplier to effect the Supplies. This shall not apply in cases of mandatory liability based on intent, gross negligence, or due to injury of life, body or health. Cancellation of the contract by the Purchaser based on statute shall be limited to cases where the Supplier is responsible for the delay. The above provisions do not imply a change in the burden of proof to the detriment of the Purchaser.
5. At the Supplier's request the Purchaser shall declare within a reasonable period of time whether the Purchaser cancels the contract due to the delayed Supplies or insists on the Supplies to be carried out.
6. If dispatch or shipment is delayed at the Purchaser's request by more than one month after notice of the readiness for dispatch was given, the Purchaser may be charged, for every month commenced, storage costs of 0.5 % of the price of the items of the Supplies, but in no case more than a total of 5 %. The parties to the contract may prove that higher or, as the case may be, lower storage costs have been incurred.

### V. TRANSFER OF RISK

1. Even where delivery has been agreed freight free, the risk shall pass to the Purchaser as follows:
  - a) if the Supplies do not include assembly or erection, at the time when the Supplies are shipped or picked up by the carrier. Upon request of the Purchaser, the Supplier shall insure the Supplies against the usual risks of transport at the expense of the Purchaser;
  - b) if the Supplies include assembly or erection, at the day of taking over in the own works or, if so agreed, after a fault-free trial run.
2. The risk shall pass to the Purchaser if dispatch, shipping, the start or performance of assembly or erection, the taking over in the own works or the trial run is delayed for reasons for which the Purchaser is responsible or if the Purchaser has otherwise failed to accept the Supplies.

### VI. ASSEMBLY AND ERECTION

Unless otherwise agreed in writing, assembly/erection shall be subject to the following provisions:

1. The Purchaser shall provide at its own expense and in good time:
  - a) all earth and construction work and other ancillary work outside the scope of the Supplier, including the necessary skilled and unskilled labour, construction materials and tools,
  - b) the equipment and materials necessary for assembly and commissioning such as scaffolds, lifting equipment and other devices as well as fuels and lubricants,
  - c) energy and water at the point of use including connections, heating and lighting,
  - d) suitable dry and lockable rooms of sufficient size adjacent to the site for the storage of machine parts, apparatus, materials, tools, etc. and adequate working and recreation rooms for the erection personnel, including sanitary facilities as are appropriate in the specific circumstances. Furthermore, the Purchaser shall take all measures it would take for the protection of its own possessions to protect the possessions of the Supplier and of the erection personnel at the site,
  - e) protective clothing and protective devices needed due to particular conditions prevailing on the specific site.
2. Before the erection work starts, the Purchaser shall make available of its own accord any information required concerning the location of concealed electric power, gas and water lines or of similar installations as well as the necessary structural data.
3. Prior to assembly or erection, the materials and equipment necessary for the work to start must be available on the site of assembly/erection and any preparatory work must have advanced to such a degree that assembly/erection can be started as agreed and carried out without interruption. Access roads and the assembly/erection site itself must be level and clear.
4. If assembly, erection or commissioning is delayed due to circumstances for which the Supplier is not responsible, the Purchaser shall bear the reason-

\* Translation of the original German text

able costs incurred for idle times and any additional travelling of the Supplier or the erection personnel.

- The Purchaser shall attest to the hours worked by the erection personnel towards the Supplier at weekly intervals and the Purchaser shall immediately confirm in writing if assembly, erection or commissioning has been completed.
- If, after completion, the Supplier demands acceptance of the Supplies, the Purchaser shall comply therewith within a period of two weeks. In default thereof, acceptance is deemed to have taken place. Acceptance is also deemed to have been effected if the Supplies are put to use, after completion of an agreed test phase, if any.

## VII. RECEIVING OF SUPPLIES

The Purchaser shall not refuse to receive Supplies due to minor defects.

## VIII. DEFECTS AS TO QUALITY

The Supplier shall be liable for defects as to quality („Sachmängel“, hereinafter referred to as „Defects“) as follows:

- All parts or services where a Defect becomes apparent within the limitation period shall, at the discretion of the Supplier, be repaired, replaced or provided again free of charge irrespective of the hours of operation elapsed, provided that the reason for the Defect had already existed at the time when the risk passed.
- Claims based on Defects are subject to a limitation period of 12 months. This provision shall not apply where longer periods are prescribed by law according to Sec. 438 para. 1 No. 2 (buildings and things used for a building), Sec. 479 para. 1 (right of recourse), and Sec. 634a para. 1 No. 2 (defects of a building) German Civil Code („BGB“), as well as in cases of injury of life, body or health, or where the Supplier intentionally or grossly negligently fails to fulfil its obligation or fraudulently conceals a Defect. The legal provisions regarding suspension of expiration („Ablaufhemmung“), suspension („Hemmung“) and recommencement of limitation periods remain unaffected.
- The Purchaser shall notify Defects to the Supplier in writing and without undue delay.
- In the case of notification of a Defect, the Purchaser may withhold payments to a reasonable extent taking into account the Defect occurred. The Purchaser, however, may withhold payments only if the subject-matter of the notification of the Defect occurred is justified beyond doubt. Unjustified notifications of Defect shall entitle the Supplier to have its expenses reimbursed by the Purchaser.
- The Supplier shall first be given the opportunity to supplement its performance („Nacherfüllung“) within a reasonable period of time.
- If supplementary performance is unsuccessful, the Purchaser shall be entitled to cancel the contract or reduce the remuneration, irrespective of any claims for damages it may have according to Art. XI.
- There shall be no claims based on Defect in cases of insignificant deviations from the agreed quality, of only minor impairment of usefulness, of natural wear and tear or damage arising after the transfer of risk from faulty or negligent handling, excessive strain, unsuitable equipment, defective workmanship, inappropriate foundation soil or from particular external influences not assumed under the contract, or from non-reproducible software errors. Claims based on defects attributable to improper modifications or repair work carried out by the Purchaser or third parties and the consequences thereof shall be likewise excluded.
- The Purchaser shall have no claim with respect to expenses incurred in the course of supplementary performance, including costs of travel and transport, labour, and material, to the extent that expenses are increased because the subject-matter of the Supplies was subsequently brought to another location than the Purchaser's branch office, unless doing so complies with the intended use of the Supplies.
- The Purchaser's right of recourse against the Supplier pursuant to Sec. 478 BGB is limited to cases where the Purchaser has not concluded an agreement with its customers exceeding the scope of the statutory provisions governing claims based on Defects. Moreover, No. 8 above shall apply mutatis mutandis to the scope of the right of recourse the Purchaser has against the Supplier pursuant to Sec. 478 para. 2 BGB.
- Furthermore, the provisions of Art. XI (Other Claims for Damages) shall apply in respect of claims of damages. Any other claims of the Purchaser against the Supplier or its agents or any such claims exceeding the claims provided for in this Art. VIII, based on a Defect, shall be excluded.

## IX. INDUSTRIAL PROPERTY RIGHTS AND COPYRIGHT; DEFECTS IN TITLE

- Unless otherwise agreed, the Supplier shall provide the Supplies free from third parties' industrial property rights and copyrights (hereinafter referred to as „IPR“) with respect to the country of the place of destination. If a third party asserts a justified claim against the Purchaser based on an infringement of an IPR with respect to the Supplies made by the Supplier and then used in conformity with the contract, the Supplier shall be liable to the Purchaser within the time period stipulated in Art. VIII No. 2 as follows:
  - The Supplier shall choose whether to acquire, at its own expense, the right to use the IPR with respect to the Supplies concerned or whether to

modify the Supplies such that they no longer infringe the IPR or replace them. If this would be unreasonable to demand from the Supplier, the Purchaser may cancel the contract or reduce the remuneration pursuant to the appli-cable statutory provisions.

- The Supplier's liability to pay damages shall be governed by Art. XI.
  - The above obligations of the Supplier shall only apply if the Purchaser (i) immediately notifies the Supplier of any such claim asserted by the third party in writing, (ii) does not concede the existence of an infringement and (iii) leaves any protective measures and settlement negotiations to the discretion of the Supplier. If the Purchaser stops using the Supplies in order to reduce the damage or for other good reason, it shall be obliged to point out to the third party that no acknowledgement of the alleged infringement may be inferred from the fact that the use has been discontinued.
- Claims of the Purchaser shall be excluded if it is itself responsible for the infringement of an IPR.
  - Claims of the Purchaser shall also be excluded if the infringement of the IPR is caused by specifications made by the Purchaser, to a type of use not foreseeable by the Supplier or to the Supplies being modified by the Purchaser or being used together with products not provided by the Supplier.
  - In addition, with respect to claims by the Purchaser pursuant to No. 1 a) above, Art. VIII Nos. 4, 5, and 9 shall apply mutatis mutandis in the event of an infringement of an IPR.
  - Where other defects in title occur, Art. VIII shall apply mutatis mutandis.
  - Any other claims of the Purchaser against the Supplier or its agents or any such claims exceeding the claims provided for in this Art. IX, based on a defect in title, shall be excluded.

## X. IMPOSSIBILITY OF PERFORMANCE; ADAPTATION OF CONTRACT

- To the extent that Supplies are impossible to be carried out, the Purchaser shall be entitled to claim damages, unless the Supplier is not responsible for the impossibility. The Purchaser's claim for damages shall, however, be limited to an amount of 10 % of the value of the part of the Supplies which, owing to the impossibility, cannot be put to the intended use. This limitation shall not apply in the case of mandatory liability based on intent, gross negligence or injury of life, body or health; this does not imply a change in the burden of proof to the detriment of the Purchaser. The right of the Purchaser to cancel the contract shall remain unaffected.
- Where unforeseeable events within the meaning of Art. IV No. 2 substantially change the economic importance or the contents of the Supplies or considerably affect the Supplier's business, the contract shall be adapted taking into account the principles of reasonableness and good faith. Where doing so is economically unreasonable, the Supplier shall have the right to cancel the contract. If the Supplier intends to exercise its right to cancel the contract, it shall notify the Purchaser thereof without undue delay after having realised the repercussions of the event; this shall also apply even where an extension of the delivery period had previously been agreed with the Purchaser.

## XI. OTHER CLAIMS FOR DAMAGES

- Any claims for damages and reimbursement of expenses the Purchaser may have (hereinafter referred to as „Claims for Damages“), based on whatever legal reason, including infringement of duties arising in connection with the contract or tort, shall be excluded.
- The above shall not apply in the case of mandatory liability, e. g. under the German Product Liability Act („Produkthaftungsgesetz“), in the case of intent, gross negligence, injury of life, body or health, or breach of a condition which goes to the root of the contract („wesentliche Vertragspflichten“). However, Claims for Damages arising from a breach of a condition which goes to the root of the contract shall be limited to the foreseeable damage which is intrinsic to the contract, unless caused by intent or gross negligence or based on liability for injury of life, body or health. The above provision does not imply a change in the burden of proof to the detriment of the Purchaser.
- To the extent that the Purchaser has a valid Claim for Damages according to this Art. XI, it shall be time-barred upon expiration of the limitation period applicable to Defects pursuant to Art. VIII No. 2. In the case of claims for damages under the German Product Liability Act, the statutory provisions governing limitation periods shall apply.

## XII. VENUE AND APPLICABLE LAW

- If the Purchaser is a businessperson, sole venue for all disputes arising directly or indirectly out of the contract shall be the Supplier's place of business. However, the Supplier may also bring an action at the Purchaser's place of business.
- Legal relations existing in connection with this contract shall be governed by German substantive law, to the exclusion of the United Nations Convention on Contracts for the International Sale of Goods (CISG).

## XIII. SEVERABILITY CLAUSE

The legal invalidity of one or more provisions of this contract shall in no way affect the validity of the remaining provisions. This shall not apply if it would be unreasonable for one of the parties to continue the contract.

## Notes

## HENGSTLER INTERNATIONAL

---

### ■ GERMANY

Hengstler GmbH  
Uhlandstr. 49  
78554 Aldingen  
Tel. +49-74 24-8 90  
Fax +49-74 24-8 94 70/ 89 500  
<http://www.hengstler.com>  
[info@hengstler.de](mailto:info@hengstler.de)

---

### ■ FRANCE

Hengstler Contrôle Numérique  
S.A.R.L.  
Z.I. des Mardelles  
94-106, Rue Blaise Pascal, B.P. 71  
93602 Aulnay-sous-Bois, Cédex  
Tel. (01) 48795500  
Fax (01) 48795561  
<http://www.hengstler.fr>

---

### ■ GREAT BRITAIN

West Instruments  
The Hyde  
Brighton, East Sussex  
BN2 4JU, England  
Tel. +44 (0) 1273 606271  
Fax +44 (0) 1273 609990  
[info@west-inst.co.uk](mailto:info@west-inst.co.uk)  
<http://www.westinstruments.com>

---

### ■ ITALY

ICG Holding S.r.l.  
Via Leonardo da Vinci, 45/47  
20020 Lainate (MI)  
Tel. 0039-02 9330011  
Fax 0039-02 93300129  
[info@icg-holding.com](mailto:info@icg-holding.com)

---

### ■ SLOVAKIA

Hengstler sro  
Pradiaren 40  
060 01 Kezmarok  
Tel :+421 52 46803 19,  
Fax:+421 52 46803 99  
[milan.balla@hengstler.com](mailto:milan.balla@hengstler.com)

---

### ■ BRASIL

Veeder Root do Brasil  
Com. e. Ind. Ltda.  
Rua Ado Benatti, 92  
Sao Paulo SP  
CEP 05037-904  
Tel 0055 11 361 121 55  
Fax 0055 11 36 11 982  
[Antonio\\_Araujo@veeder.com](mailto:Antonio_Araujo@veeder.com)

---

### ■ CHINA

Danaher ICG China  
Shanghai Office  
Room.904,Tower 1,  
Kerry Everbright City  
No.218,Tian Mu Road(W)  
Shanghai 200070, China  
Tel:+86 21 63539541, 33030472  
Fax:+86 21 33030345  
[william.liu@danahericg.com.cn](mailto:william.liu@danahericg.com.cn)

---

### ■ CHINA

Danaher ICG - China  
Beijing Office  
Room 2202, Scitech Tower  
22 Jianguomen Wai Street  
Beijing 100004 PR China  
Tel: 86-10-6512-0195  
Fax: 86-10-6522-0887  
[frank.li@danahericg.com.cn](mailto:frank.li@danahericg.com.cn)

---

### ■ CHINA

Danaher ICG - China  
Guangzhou Office  
Room B2, 15th Floor,  
Gao Sheng Building  
No.109 Ti Yu Xi Road  
Guangzhou 510620, China  
Tel: +86 20-22646072  
Fax: +86 20-22646069  
[tourist.luo@danahericg.com.cn](mailto:tourist.luo@danahericg.com.cn)

---

### ■ AGENTS

Argentina, Australia, Austria, Belgium, Brazil, Chile, China, Croatia, Czech Republic, Denmark, El Salvador, Estonia, Finland, France, Germany, Greece, Hong Kong, Hungary, India, Indonesia, Israel, Italia, Japan, Korea, Lebanon, Luxemburg, Malaysia, Mexico, Netherlands, New Zealand, Norway, Peru, Philippines, Poland, Portugal, Romania, Serbia and Montenegro, Singapore, Slovakia, Slovenia, South Africa, Spain, Sweden, Switzerland, Taiwan, Thailand, Turkey, Ukraine, United Kingdom, United Arab Emirates, USA, Vietnam

---

### ■ JAPAN

Danaher ICG Japan Co. Ltd.  
2-12-23, Minamikaneden  
Suita-shi  
Osaka 564-0044  
Tel. (06) 63868001  
Fax (06) 63865022  
[csc@danaher.co.jp](mailto:csc@danaher.co.jp)  
<http://www.hengstler.co.jp/>

---

### ■ SINGAPORE

Danaher Industrial Control  
Group - Singapore  
246 MacPherson Road  
#08-01 Betime Building  
Singapore 348578  
Tel. 65-6-7459265,  
Fax 65-6-7461791  
Pager: 94158924  
[fredtay@singnet.com.sg](mailto:fredtay@singnet.com.sg)

---

### ■ USA

Danaher Controls  
1675 Delaney Road  
Gurnee, IL 60031-1282  
Tel. (847) 662.2666  
Fax (847) 662.6633  
[dancon@dancon.com](mailto:dancon@dancon.com)  
<http://www.dancon.com>

---

## HENGSTLER

Hengstler GmbH  
Uhlandstr. 49  
78554 Aldingen  
Tel. +49-74 24-8 90  
Fax +49-74 24-8 94 70/ 89 500  
<http://www.hengstler.com>  
[info@hengstler.de](mailto:info@hengstler.de)



TÜV certified according to DIN EN  
ISO 9001: 2000 and ISO 14001: 2004  
Reg. No. 12 100/104 32249 TMS



**[www.hengstler.de](http://www.hengstler.de)**  
**0800-HENGSTLER**  
**436478537**

DOC 1209.19 E

Encoders programme · 04/2008 / 1000 · HohlDruck  
printed in Germany on environmentally friendly paper  
from chlorine- and acid-free production